

GUIDE FOR
ARCHITECTURAL-ENGINEERING FIRMS

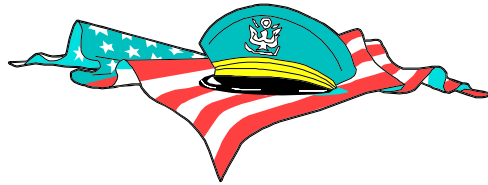

A-E
GUIDE



SOUTHWEST DIVISION

EFD/SOUTHWEST EFA/WEST EFA/NORTHWEST
NAVAL FACILITIES ENGINEERING COMMAND

MAY 1997

Foreword

1. The purpose of this guide is to supplement the Architect-Engineer (A-E) Scope of Work, Naval Facilities Engineering Command instructions and related Department of Defense design criteria. The guide is intended to be a ready reference source of information to help improve the quality of our end product. Members of A-E firms performing engineering and design services for the Department of the Navy, Southwest Division, Naval Facilities Engineering Command, should read the guide and become familiar with its contents.

2. I want to personally emphasize our commitment to quality design and cost consciousness, and to give you my views on your responsibility as a designer for the Department of Defense. There is much national attention these days on government spending and cost overruns, and, like other defense spending, military construction is receiving its share of scrutiny. All of us involved with military construction programs must reaffirm our efforts to manage our projects wisely, to be quality conscious, and to eliminate any cost overruns or excesses. The facilities we design are our most visible product, so unless our designs are functional, conservative, and economical, we leave ourselves open for criticism. Any time we exceed the programmed amount for our projects, we risk being viewed as "another defense cost overrun indicative of poor management and/or inadequate engineering." The Navy Department and other Department of Defense agencies insist on quality construction that will meet the user's needs with a minimum of initial cost and future maintenance. These requirements must originate with a quality design.

3. You are a key member of our team. Members of the Southwest Division staff will work with you at any stage of the project to answer questions and provide additional guidance to assure complete, professional end products result. A-E firms assume full responsibility for the technical accuracy and professional adequacy of any work or materials which they furnish under a contract with Southwest Division. Your submittals will be reviewed by the Navy only to verify conformance with the authorized scope and applicable Department of Defense design criteria and that construction can be completed within the authorized funding limits.

4. I encourage your firm to make comments to my design staff in any areas that you feel could result in less bureaucracy and more efficient engineering and design contract management. Our ultimate goal is to provide our customers quality facilities at lower cost and better maintainability features. Suggestions in this area or any others which can improve our process and contribute to the continued harmonious relationship between the A-E community and this command will be gratefully received.

M. R. JOHNSON
Captain, CEC, U.S. Navy
Commander, Southwest Division,
Naval Facilities Engineering Command

Date: 23 May 1997

RECORD OF REVISIONS

REV. NO.	DATE OF REVISION	CHAPTER NUMBERS REVISED	DATE ENTERED	APPROVED BY
1	13 Feb 96	New West Coast Guide	13 Feb 96	R. Cook
2	23 May 97	Revised/Re-engineering	23 May 97	D. Nielsen
A-E Guide Changes.				
Anyone may propose changes to the Guide. All Changes are carefully reviewed for final publication. Send your proposed changes to :				
Southwest Division Naval Facilities Engineering Command Regional Specialty Support Team, Code 570 Anthony Fairchild, Senior Architect, Code 5711 1220 Pacific Highway San Diego, CA 92132 FAX: (619) 532-3180				

Table Of Contents

Page

FOREWORD i

RECORD OF REVISIONS..... ii

TABLE OF CONTENTS iii

CHAPTER 1. GENERAL REQUIREMENTS 1

1.1 GENERAL..... 1

1.2 DEFINITIONS 1

1.3 PRE-NEGOTIATION CONFERENCES 3

1.4 A-E DESIGN/PERFORMANCE AWARDS 4

1.4.1 Naval Facilities Engineering Command Design Awards Program..... 4

1.4.2 Design Excellence Awards..... 4

1.4.3 Industrial Incentive Awards Plan 4

1.4.4 Certificate of Appreciation 4

1.4.5 Competition of the Construction Specifications Institute (CSI) 5

1.4.6 Other Awards..... 5

1.5 A-E EVALUATION 5

1.5.1 A-E Performance Evaluation..... 5

1.5.2 Interim A-E Evaluation 5

CHAPTER 2. GENERAL PERFORMANCE REQUIREMENTS..... 7

2.1 GENERAL..... 7

2.2 STATEMENT OF ARCHITECT-ENGINEERING SERVICES 7

2.2.1 Deviations and Changes in The Statement of A-E Services 7

2.2.2 Precedence..... 7

2.2.3 Quality Assurance..... 7

2.2.4 A-E Quality Assurance 8

2.2.5 Command Review 8

2.3 LIAISON BETWEEN A-E AND THE COMMAND 8

2.4 NOTICE TO PROCEED 8

2.5 PROJECT COST LIMITATION..... 8

2.6 REVIEW COMMENTS 9

2.6.1 Review Comments Resolution 9

2.6.2 Review Comment Presentation Options..... 9

2.7 TECHNICAL ADMINISTRATION AUTHORITY (PROCEDURES 1 & 11) 9

2.7.1 Procedure I..... 9

2.7.2 Procedure II..... 10

2.8 CONTACTS WITH COMMERCIAL UTILITIES 10

2.9 BASE PASSES & SECURITY CLEARANCES 10

2.10 PROJECT DOCUMENTATION 10

2.11 A-E RELEASE OF INFORMATION PROHIBITED..... 10

2.12 AVAILABLE SITE INFORMATION VERIFICATION..... 11

2.12.1 A-E Verification 11

2.13 REQUESTS FOR INFORMATION 11

2.13.1 Bid Inquiries..... 11

2.13.2 COR 11

2.14 A-E COMMUNICATIONS DURING CONSTRUCTION..... 12

CHAPTER 3. ENGINEERING SERVICES..... 15

3.1 GENERAL..... 15

3.1.1 A-E Proposed ES..... 15

3.1.2 Field Surveys..... 15

3.2 DESIGN QUALITY CONTROL PLAN (DQCP) 15

3.3 FIELD INVESTIGATIONS 16

3.4 SURVEYS.....	16
3.4.1 Survey Monuments.....	17
3.4.2 Aerial Surveys.....	17
3.4.3 Cadastral Surveys.....	17
3.4.4 Hydrographic Surveys.....	17
3.5 GEOTECHNICAL INVESTIGATION.....	17
3.5.1 Soil Testing and Earthwork Standards.....	18
3.5.2 Boring Logs.....	18
3.5.3 Report.....	19
3.5.4 Geotechnical Review Certification.....	19
3.6 SITE SEISMICITY.....	19
3.6.1 Procedures For Developing Seismic Ground Motions.....	20
3.7 ENGINEERING DOCUMENTATION.....	20
3.8 ARCHITECTURAL REVIEW BOARD (ARB).....	21
3.9 VALUE ENGINEERING POLICY AND GUIDANCE (VE).....	23
3.9.1 Introduction.....	23
3.9.2 VE Team Studies.....	23
3.9.2.1 Indefinite Quantity Contracts.....	23
3.9.2.2 A-E Scope Of Work For Value Engineering Services.....	24
3.9.3 VE Reports.....	24
3.10 COLOR RENDERINGS.....	24
3.10.1 Color Freehand Renderings.....	24
3.10.2 Color CADD Daytime Renderings.....	25
3.11 ENERGY CONSERVATION REPORT.....	25
3.12 COMPREHENSIVE INTERIOR SERVICES FOR FURNITURE AND FURNISHINGS PROCUREMENT.....	26
3.12.1 Schedule Of Submittal For Comprehensive Interior Services.....	26
3.12.2 Comprehensive Interior Services For Medical And Dental Facilities.....	26
3.13 MANDATORY PROCUREMENT SOURCES FOR FURNITURE AND FURNISHINGS.....	27
3.14 CONCEPT STUDIES FOR HOUSING REPAIR AND IMPROVEMENT.....	27
3.15 SITE ENGINEERING INVESTIGATIONS (SEI) AND REPORTS FOR TURNKEY HOUSING AND DESIGN/BUILD PROJECTS.....	27
3.16 CORROSIVE SOIL AND/OR WATER.....	27
3.17 OCCUPATIONAL SAFETY AND HEALTH REPORT.....	28
3.17.1 Regulations.....	28
3.17.2 Planning And Design For Safety.....	28
3.18 ASBESTOS SAMPLES ANALYSIS, REMOVAL AND DISPOSAL REPORT.....	29
3.18.1 Facility Changes.....	29
3.18.2 Site Investigation Of Suspect Materials.....	30
3.18.3 Regulated Amounts Of Asbestos Materials.....	30
3.18.4 Sampling and Analysis Report.....	31
3.19 PAINTS and OTHER CHEMICAL COATINGS; SAMPLE ANALYSIS, REMOVAL AND DISPOSAL REPORT.....	31
3.19.1 Approved Sampling Plan.....	31
3.19.2 Sample Analysis.....	31
3.19.3 Work Plan.....	31
3.19.4 Laboratory Analysis.....	32
3.20 ENVIRONMENTAL PERMIT REQUIREMENTS INVESTIGATION, REPORT, PERMIT APPLICATIONS AND CONSOLIDATED COMPLIANCE ASSESSMENT REPORT.....	32
3.20.1 Design Compliance.....	32
3.20.2 Permit Application Submittal.....	32
3.20.3 Permit Requirements Report.....	32
3.20.4 Consolidated Compliance Assessment Report.....	33
3.21 SOLAR ENERGY STUDY.....	33
3.22 SHORT CIRCUIT AND COORDINATION STUDY.....	33
3.23 DESTRUCTIVE TESTING.....	34

3.24	FIELD VERIFICATION PRIOR TO CONSTRUCTION	34
3.25	DESIGNER TO ROICC REPORT	34
3.26	DESIGNER TO ROICC PRESENTATION	34
3.27	TRAVEL.....	35
CHAPTER 4.	CONSTRUCTION CONTRACT SUPPORT SERVICES	43
4.1	OFFICE CONSULTATION	43
4.2	SUBMITTAL REVIEW	43
4.2.1	Stamped Notation	43
4.2.2	Responsibility.....	44
4.3	OPERATION AND MAINTENANCE SUPPORT INFORMATION (OMSI) REQUIREMENTS	44
4.3.1	OMSI Manuals	44
4.3.2	OMSI Types.....	45
4.4	RECORD DRAWINGS	45
4.4.1	General Procedure.....	46
4.4.2	Computer Graphics Data-Base	46
4.4.3	Correction of Original Drawings	46
4.5	FIELD CONSULTATIONS DURING CONSTRUCTION.....	47
4.5.1	Field Consultation Report.....	47
4.5.2	Site Access.....	47
4.6	EVALUATION OF VALUE ENGINEERING CHANGE PROPOSALS (VECP's).....	47
CHAPTER 5.	SUBMITTALS	49
5.1	SUBMITTAL REQUIREMENTS.....	49
5.1.1	Design Quality Control Plan	49
5.1.2	15 Percent Design (a)	49
5.1.3	45 Percent Design (a), (c), (d).....	49
5.1.4	100 Percent Design (a), (b), (c), (d).....	49
5.1.5	Final Design (a), (c), (d)	50
5.1.6	Transmittals.....	51
5.2	REPORTS, ENGINEERING CALCULATIONS, FIELD NOTEBOOKS AND MISCELLANEOUS DATA.....	51
5.2.1	Computer Documentation	51
5.2.2	Computer Graphics Documentation	51
5.2.3	Metric Measurements.....	52
5.2.3.1	Hard Metric	52
5.2.3.2	Soft Metric.....	52
5.2.3.3	Metric Requirements	52
5.3	INTERIOR AND EXTERIOR FINISH BOARDS	53
5.4	RESUBMITTAL.....	53
CHAPTER 6.	BASIS OF DESIGN REPORT	59
6.1	GENERAL.....	59
6.1.1	Criteria.....	59
6.1.2	Computer Graphics.....	59
6.2	CODE CRITERIA SEARCH	59
6.2.1	Code Criteria Search	59
6.2.2	Sources Of Design Criteria	60
6.3	GENERAL INFORMATION	60
6.3.1	Station Master Plan.....	60
6.3.1.1	Base Exterior Architecture Plan (BEAP)	60
6.3.1.2	Site Planning.....	60
6.3.2	Program Requirements.....	61
6.3.2.1	Design Area Tabulation.....	61

6.3.2.2 Building Design	61
6.3.3 Energy Conservation	61
6.3.4 Weight Handling Equipment	61
6.3.5 Construction Permit Information.....	62
6.3.6 Physical Security	62
6.3.6.1 Physical Security Hardening.....	62
6.3.6.2 Doors, Windows And Wall Penetrations	62
6.3.6.3 Plans And Specifications.....	62
6.4. ENVIRONMENTAL REQUIREMENTS	62
6.4.1 Environmental Assessment/Environmental Impact Statement (EA/EIS)	62
6.5 CIVIL ENGINEERING	63
6.5.1 Site Grading.....	63
6.5.2 Utilities.....	63
6.5.3 Storm Sewer System And Surface Drainage.....	63
6.5.4 Water Systems	64
6.5.5 Sanitary Sewer Systems	65
6.5.6 Sewage Treatment System.....	65
6.5.7 Dust And Erosion Control.....	65
6.5.8 Fencing.....	65
6.5.9 Railroads	65
6.5.10 Paving	66
6.5.11 Airfield Pavement Systems	66
6.6 LANDSCAPE ARCHITECTURE.....	66
6.6.1 Irrigation Systems	67
6.6.2 Plant Materials.....	67
6.6.3 Other Site Features.....	67
6.7 ARCHITECTURE	67
6.7.1 Passive Features	68
6.7.2 Movable Partitions	68
6.7.3 Equipment Rooms	68
6.7.4 Roof Structure	68
6.7.4.1 Slope.....	68
6.7.4.2 Drains, Roof	68
6.7.4.3 Parapets.....	68
6.7.5 Colors, Materials and Finishes.....	69
6.8 STRUCTURAL.....	69
6.8.1 Seismic Design Criteria.....	69
6.8.2 Foundation Conditions	70
6.8.3 Type Of Construction	70
6.8.4 Materials.....	70
6.8.5 Live Loads	70
6.8.6 Lateral Forces.....	70
6.8.7 Seismic Design.....	71
6.8.7.1 Metal Deck Diaphragms	71

6.8.7.2 Concrete Slabs On Grade	71
6.8.7.3 Pre-Engineered Metal Buildings	71
6.8.7.4 Reinforced Concrete Masonry Construction.....	71
6.9 MECHANICAL.....	72
6.9.1 Heating, Ventilating And Air Conditioning (HVAC).....	72
6.9.1.1 Heating.....	72
6.9.1.2 Ventilation	72
6.9.1.3 Cooling.....	73
6.9.2 Plumbing	73
6.9.3 Cold Storage.....	73
6.9.4 Heating Plants	74
6.9.5 Exterior Distribution Systems	74
6.9.6 Fuel Distribution And Storage	74
6.9.7 Elevators, Pneumatic Tube Systems.....	75
6.10 ELECTRICAL.....	75
6.10.1 Facilities	75
6.10.2 Electrical Distribution System.....	77
6.10.3 Instrumentation And Control Systems	77
6.11 FIRE PROTECTION	78
6.12 CATHODIC PROTECTION	79
CHAPTER 7. DRAWINGS.....	81
7.1 GENERAL.....	81
7.1.1 Quality Control Check Set Procedures	81
7.1.2 Additive Designation	81
7.2 DRAWING REQUIREMENTS	81
7.2.1 Order Of Drawings.....	81
7.2.2 Title Sheet	82
7.2.2.1 Storm Water Discharge Requirements	82
7.2.3 Drawing Orientation	82
7.2.4 Drafting Media	82
7.2.5 Lettering And Shading.....	83
7.2.6 Scales.....	83
7.2.7 Title And Revision Blocks	83
7.2.8 NAVFAC Drawing Numbers.....	83
7.2.9 Sheet Number.....	84
7.2.10 Drawing Reference Numbers.....	84
7.2.11 Section/Detail Identification.....	84
7.2.12 Signatures And Corporate Stamps on Drawings.....	84
7.2.13 Stamps On Drawings	84
7.2.14 Revisions To Contract Drawings	85
7.2.14.1 Revision Symbol	85
7.2.14.2 Revision Block.....	85
7.2.14.3 Approval Of Drawings.....	85
7.3 FIFTEEN PERCENT SUBMITTAL REQUIREMENTS	85
7.4 FORTY-FIVE PERCENT SUBMITTAL	86
7.4.1 Civil Drawings.....	86
7.4.1.1 Existing Topography.....	87
7.4.1.2 Demolition Plan	87
7.4.1.3 Site Plan	88
7.4.1.4 Grading Plan	88

7.4.1.5	Paving Plan.....	89
7.4.1.6	Utility Plan.....	89
7.4.2	Geotechnical Drawings.....	89
7.4.2.1	Soil Boring Logs And Data.....	90
7.4.3	Landscape Architecture Drawings.....	90
7.4.3.1	Landscape Construction Plan.....	90
7.4.3.2	Irrigation Plan.....	90
7.4.3.3	Planting Plan.....	90
7.4.4	Architectural Drawings.....	91
7.4.4.1	Architectural Site Plan.....	91
7.4.4.2	Demolition Plans.....	91
7.4.4.3	Floor Plans.....	91
7.4.4.4	Roof Plans.....	92
7.4.4.5	Exterior Elevations.....	92
7.4.4.6	Building Sections.....	92
7.4.4.7	Wall Sections.....	92
7.4.4.8	Room Finish Schedule.....	92
7.4.4.9	Large Scale Plans.....	92
7.4.4.10	Interior Elevations.....	92
7.4.4.11	Equipment Layouts.....	92
7.4.5	Structural Drawings.....	93
7.4.5.1	General Notes And Typical Details.....	93
7.4.5.2	Foundation Plan.....	93
7.4.5.3	Floor And Roof Framing Plans.....	93
7.4.5.4	Elevations.....	94
7.4.5.5	Sections And Details.....	94
7.4.6	Mechanical Drawings.....	94
7.4.7	Plumbing Drawings.....	94
7.4.8	Electrical Drawings.....	95
7.4.8.1	Notes, Legends And Symbols List.....	95
7.4.8.2	Demolition Plan.....	95
7.4.8.3	Site Plan.....	95
7.4.8.4	Single Line Diagrams.....	95
7.4.8.5	Floor Plans.....	96
7.4.9	Fire Protection System(s).....	96
7.5	PROJECT DRAWINGS - 100 PERCENT SUBMITTAL.....	96
7.5.1	Civil Drawings.....	97
7.5.1.1	Existing Topography.....	97
7.5.1.2	Demolition Plan.....	97
7.5.1.3	Utility Plan.....	98
7.5.1.4	Site Plan.....	98
7.5.1.5	Grading Plan.....	98
7.5.1.6	Paving Plan.....	99
7.5.1.7	Plan And Profile.....	100
7.5.1.8	Profiles.....	100
7.5.1.9	Cross Sections.....	100
7.5.1.10	Dredging Drawings.....	101
7.5.1.11	Details And Sections, Civil.....	103
7.5.1.12	Painting And Striping.....	103
7.5.2	Landscape Architecture.....	103
7.5.2.1	Landscape Architecture Plan.....	103
7.5.2.2	Irrigation Plan.....	104
7.5.2.3	Planting Plan.....	104
7.5.2.4	Irrigations Details.....	105
7.5.2.5	Planting, Site Furniture, And Drainage Details.....	105
7.5.3	ARCHITECTURAL DRAWINGS.....	105

7.5.3.1	Architectural Site Plan	106
7.5.3.2	Demolition Plans	106
7.5.3.3	Floor Plans	106
7.5.3.4	Reflected Ceiling Plans	107
7.5.3.5	Roof Plans	107
7.5.3.6	Exterior Elevations	107
7.5.3.7	Building Sections.....	107
7.5.3.8	Wall Sections	107
7.5.3.9	Room Finish Schedule	107
7.5.3.10	Door And Window Schedules	107
7.5.3.11	Large Scale Plans	107
7.5.3.12	Interior Elevations	108
7.5.3.13	Door And Window Details.....	108
7.5.3.14	Miscellaneous Details.....	108
7.5.3.15	Equipment Layouts.....	108
7.5.4	Structural Drawings.....	108
7.5.4.1	General Notes And Typical Details	109
7.5.4.2	Foundation Plan	109
7.5.4.3	Floor And Roof Framing Plans	109
7.5.4.4	Elevations	110
7.5.4.5	Sections And Details	111
7.5.4.6	Schedules	111
7.5.4.7	Other Drawings	111
7.5.4.8	Seismic Anchorage Of Pipes, Ducts And Equipment	111
7.5.5	Mechanical Drawings.....	113
7.5.5.1	Plot Plan	114
7.5.5.2	Large Scale Plot Plans	114
7.5.5.3	Mechanical Plans	114
7.5.5.4	Large Scale Mechanical Plans.....	114
7.5.5.5	Elevations/Sections	115
7.5.5.6	Details.....	115
7.5.5.7	Isometric And Schematic Diagrams	115
7.5.5.8	Control Diagrams	115
7.5.5.9	Sequence Of Operation.....	115
7.5.5.10	Equipment Schedules.....	116
7.5.6	Plumbing Drawings.....	116
7.5.6.1	Plot Plan	117
7.5.6.2	Large Scale Plot Plans	117
7.5.6.3	Plumbing Plans	117
7.5.6.4	Large Scale Plumbing Plans.....	117
7.5.6.5	Elevations/Sections	118
7.5.6.6	Details.....	118
7.5.6.7	Isometric/Schematic Diagrams	118
7.5.6.8	Equipment Schedules.....	118
7.5.7	Electrical Drawings	118
7.5.7.1	Notes, Legends, And Symbols List	119
7.5.7.2	Demolition Plan	119
7.5.7.3	Site Plan	119
7.5.7.4	Floor Plans.....	120
7.5.7.5	Diagram	120
7.5.7.6	Schedules And Tables.....	121
7.5.7.7	Sections And Details	121
7.5.8	Cathodic Protection.....	122
7.5.8.1	Site Plan	122
7.5.8.2	Diagrams.....	122
7.5.9	Fire Protection Drawings.....	122

7.5.9.1	Water Distribution.....	122
7.5.9.2	Fire Rated Walls, Doors And Exits	122
7.5.9.3	Gaseous Type Extinguishing Systems.....	123
7.5.9.4	Galley/Kitchen Hood Extinguishing Systems	123
7.5.9.5	Wet-Pipe Fire Sprinkler Systems	123
7.5.9.6	Pre-Action/Deluge Systems (in addition to 7.5.9.3 above)	123
7.5.9.7	Fire Pumping Systems	123
7.5.9.8	Fire Alarm Systems	124
CHAPTER 8. PROJECT SPECIFICATION.....		127
8.1	GENERAL DESCRIPTION.....	127
8.2	SPECIFICATION FORMAT.....	127
8.2.1	Outline Specifications	127
8.2.2	Guide Specification Selection	127
8.2.3	Guide Specification Issue Dates.....	128
8.2.4	SPECSINTACT Specifications.....	128
8.2.5	Specification Number.....	128
8.3	RESTRICTIVE SPECIFICATIONS.....	128
8.3.1	Proprietary Products	128
8.3.2	Or Equal Specification	129
8.3.3	Extended Warranty Clauses.....	129
8.3.4	Experience Clauses.....	129
EXHIBIT 8-G.....		160
CHAPTER 9. COST ESTIMATES.....		161
9.1	GENERAL.....	161
9.1.1	Purpose Of Estimate.....	161
9.1.2	Cost Engineering Estimate Format Guide	161
9.2	PROJECT ESTIMATE REQUIREMENTS	161
9.2.1	Estimating Format And Documentation	162
9.2.2	Success.....	162
9.2.3	Detailed Estimate.....	163
9.2.4	Detailed Estimating Criteria	163
9.2.4.1	San Clemente Island And Alaska Projects.....	164
9.2.4.2	Units Of Measure	164
9.2.4.3	Estimate Detail	164
9.2.4.4	Unit Costs.....	164
9.2.5	Other Cost Factors.....	165
9.2.5.1	General Requirements	165
9.2.5.2	Estimate Escalation.....	166
9.2.5.3	Estimate Design Development Contingency	167
9.2.5.4	Additive Bid Items	167
9.2.6	Submittal Guidance	167
9.2.6.1	Parametric Cost Estimate (PCE) Submittals, 1391 Plus & 15 Percent Estimates	167
9.2.6.2	Percent Estimates	167
9.2.6.3	100 Percent Estimate	167
9.2.6.4	Final Estimates.....	168
9.3	ENGINEERING DOCUMENTATION	168
9.4	AMENDMENT ESTIMATES	168
9.5	CHANGE ORDER REQUEST ESTIMATES	168
9.6	BID ANALYSIS	169
9.7	8(a) CONTRACTS	169
9.8	OPERATION AND MAINTENANCE (O&M) PROJECTS	169
CHAPTER 10. A-E INVOICING PROCEDURES.....		170
10.1	GENERAL.....	170
10.2	INVOICE SUBMISSIONS.....	171

10.2.1 Mailing Instructions	171
10.3 INVOICING FREQUENCY	171
10.3.1 Travel	171
10.3.2 Final Invoice	171
10.4 CONTRACT PERFORMANCE STATEMENT, NAVFAC 10-7300/31 (EXHIBIT 10-A).....	172
10.4.1 Location.....	172
10.4.2 Contract.....	172
10.4.3 Sheet Numbers.....	172
10.4.4 Period Ending Date.....	172
10.4.5 Cost Category.....	172
10.4.6 Description Column (2)	172
10.4.7 Estimated Cost - Column (3).....	173
10.4.8 Percent Complete - Column (4).....	173
10.4.9 Value - Column (5).....	173
10.5 CONTRACTOR'S INVOICE, NAVFAC 7300/30, (EXHIBIT 10-B)	173
10.5.1 Invoice Date.....	173
10.5.2 Invoice Number	173
10.5.3 From.....	173
10.5.4 Contract.....	174
10.5.5 Station	174
10.5.6 Total Value Of Contract Through Modification.....	174
10.5.7 Percentage Of Performance Complete	174
10.5.8 Value Of Completed Performance	174
10.5.9 Less: Total Of Prior Invoices	174
10.5.10 Amount Of This Invoice	174
10.5.11 Signature	174
10.6 NON-ACCEPTANCE OF A-E INVOICE.....	174
10.7 DISALLOWANCE ON INVOICED AMOUNT	175
ATTACHMENT A	183
CALCULATION REQUIREMENTS	183
1. GENERAL	183
1.1 45% SUBMITTAL.....	183
1.1.1 Civil	183
1.1.2 Structural.....	183
1.1.3 Mechanical	183
1.1.4 Electrical.....	184
1.1.5 Fire Protection	184
1.2 100% SUBMITTAL.....	185
1.2.1 Civil	185
1.2.2 Irrigation System.....	185
1.2.3 Structural	185
1.2.4 Mechanical	185
1.2.5 Electrical.....	186
1.2.6 Fire Protection	186
ATTACHMENT B	187
COMPUTER AIDED DESIGN AND DRAFTING STANDARDS.....	187
1. GENERAL	187
1.1 Project Design And Construction Documents	187
2. DEFINITIONS	187
2.1 Definitions That Apply To References And Uses Included In These Standards.....	187
3. DELIVERABLES	188

3.1 Computer Files.....	188
3.1.1 Required Files.....	189
4. DOCUMENTATION DELIVERY	190
4.1 Required Documentation.....	190
5. COMPOSITION OF FILES	191
5.1 Project Drawing Characteristics.....	191
6. PROJECT SCHEDULE	192
6.1 Project Design Schedule And Phase	192
ATTACHMENT C	193
CODE CRITERIA SEARCH.....	193
APPLICABLE CODES, CRITERIA AND DESIGN POLICY:.....	193
1. OCCUPANCY.....	193
2. FIRE RESISTIVE REQUIREMENTS	195
3. ROOF ACCESS FOR MANUAL FIRE FIGHTING	195
4. FIRE PROTECTION SYSTEMS	196
5. EXITS (NFPA 101)	197
6. INTERIOR FINISH.....	198
ATTACHMENT D	200
<u>PROJECT REVIEW ENVIRONMENTAL PERMIT CHECKLIST.....</u>	200
<u>EQUIPMENT REQUIRING PERMITS.....</u>	206
ATTACHMENT E	208
<u>OPERATION AND MAINTENANCE SUPPORT INFORMATION (OMSI).....</u>	208
DIVISION 1 - GENERAL.....	209
DIVISIONS 2 THROUGH 16.....	210
Section A - Operation.....	215
Section B - Preventive Maintenance	216
Section C - Corrective Maintenance.....	217
Section D - Appendix	217

CHAPTER 1. GENERAL REQUIREMENTS

1.1 GENERAL

This A-E Guide including Attachments, by reference in the negotiated "Statement of Architect-Engineer Services (Attachment A to the Contract)", forms part of the Architect-Engineer (A-E) contract. The A-E Guide provides policies, procedures and instructions applicable to A-E firms performing design and other Architectural-Engineering services under contracts awarded by the Department of the Navy, Southwest Division, Naval Facilities Engineering Command. The "Statement of Architect-Engineer Services" will indicate the specific required services.

1.2 DEFINITIONS

- a. Activity: Marine Corps Base (MCB), Marine Corps Air Station (MCAS), Shipyard, Naval Station, Depot, Training Center, Field, Station or Center.
- b. (ACE): Activity Civil Engineer
- c. (ACE): Activity Coordination Engineer
- d. Alternate Contracting Officer's Technical Representative (ACOTR): The person appointed in writing by the Procurement Contracting Officer (PCO). The appointed ACOTR is the alternate, or backup for when the Contracting Officer's Technical Representative (COTR) is unavailable.
- e. Area Focus Team: The component department or team within the Command with the technical responsibility for the accomplishment of design programs.
- f. Assistant Resident Officer in Charge of Construction (AROICC): A naval officer who is responsible to the ROICC for the administration and surveillance of construction contracts at an activity.
- g. Contracting Officer (CO): The prime contact point for the Government on all contractual matters for the A-E, and is the only Government official to authorize changes to the contract.
- h. Change Order Requests (COR): Documents prepared when it becomes necessary to change/modify/alter the plans and/or specifications during the construction period.
- i. Command: Southwest Division, Naval Facilities Engineering Command.
- j. Construction Cost Limitation (CCL): That portion of the project budget allocated for the construction of the primary and supporting facilities. See ECC.

- k. Construction Quality Control Program: System of construction quality control as required by Contract Clause titled "Inspection of Construction" or specification General Paragraph titled Contractor Quality Control (CQC).
- l. Contracting Officer's Technical Representative (COTR): The person appointed in writing by the Procurement Contracting Officer (PCO). The appointed COTR is the focal point and primary contact between the A-E contractor and all government representatives regarding all technical matters and contractor performance issues. Work shall not begin on any contract without written authorization from the Contracting officer.
- m. (ECC): Estimated Cost of Construction is that portion of the project budget allocated for the construction of the primary and supporting facilities.
- n. Project Documentation: Engineering and Cost documentation used in support of military construction projects during the budget review.
- o. Engineering Services (ES): Engineering Services are A-E services for other than design effort. They include engineering investigations, studies, surveys, soils investigations, inspections and/or reports.
- p. Military Construction (MCON): Major Military Construction projects specifically authorized by Congress.
- q. Naval Facilities Engineering Command (NAVFACENGCOM): Headquarters, Alexandria, Virginia.
- r. Officer in Charge (OIC): Will be understood to mean Officer in Charge on A-E contracts for the organization initiating the contract.
- s. Officer in Charge of Construction (OICC): Represents the Commander in the administration of construction contracts.
- t. Operations and Maintenance Navy (O&MN): Within the context of this A-E Guide, identifies a funding source.
- u. (PCE): Parametric Cost Estimate is the process designed to develop Military Construction (MILCON) projects to a point where they can be properly defined and estimated for the Military and Congressional programming, approval, and appropriation process..
- v. Primary Facility: The building(s), structure(s) or system(s) designated as the major quantitative unit of measure of the facilities, including appurtenances and utility lines out to five feet, of the building.

- w. Procedure I: A-E contracts administered by the Command.
- x. Procedure II: A-E contracts awarded by the Command and administered by the Command OIC or the designated ROIC.
- y. Project Leader (PL) The Command designated point of contact and communication on day-to-day matters associated with the technical administration of the A-E contract, and is responsible for project scope and budget. This position was formerly called the (DM) Design Manager.
- z. (SCE): Staff Civil Engineer for a specific military installation.
- aa. Resident Officer in Charge (ROIC): Designated by the OIC to administer A-E and other types of contracts not involving construction at a specific station or activity, usually the activity Public Works Officer.
- ab. Resident Officer in Charge of Construction (ROICC): Designated by the OICC to administer and provide surveillance/inspection for construction contracts at a specific station or activity.
- ac. Resident Project Design Engineer (RPDE): The architect or engineer at a field activity designated by the ROIC to administer a specific A-E contract under Procedure II.
- ad. Scope of Work (SOW): The "STATEMENT OF ARCHITECT-ENGINEER SERVICES" (Attachment A to the contract) which delineates the general extent of the A-E's services and the special requirements of a given project.
- ae. Southwest Division: This terminology includes:
1. EFD Southwest - San Diego, CA
 2. EFA Northwest - Paulsbo, WA
 3. EFA West - San Bruno, CA
- af. Special Project: OPNAVINST 11010.20E. The terminology used by the Navy for O&MN funded projects, as differentiated from MCON. Primarily for minor construction and for repair and maintenance of real property.
- ag. Station, or User Activity: The Station or Activity responsible for operating the completed facility.
- ah. Supporting Facilities: The utilities, paved areas and site development (five feet outside of the building footprint, (1,500 mm) which are required to support the primary facility. Special foundations, i.e., pilings, engineered fill, unusually high-cost construction features and demolition are also included in supporting facilities.

1.3 PRE-NEGOTIATION CONFERENCES

The A-E is invited, at their own option and expense, to attend Pre-negotiation meetings and conduct site visits to review and clarify the scope of work and to become acquainted with the project site.

1.4 A-E DESIGN/PERFORMANCE AWARDS

The Navy participates in the A-E award programs listed below to provide appropriate recognition for outstanding performance and design. For additional information the A-E should contact the Project Leader.

1.4.1 Naval Facilities Engineering Command Design Awards Program

a. NAVFACINST 506I.7. is the instruction for NAVFAC Design Awards Program. All qualified engineering, architectural, landscape architectural and interior designs projects are eligible for nomination in this program. An entry submittal is required. Entries must have been constructed (beneficial occupancy date) no more than 3 years prior to the date of submission.

b. American Society Of Interior Designers (ASID) Biennial Competition For Achievement In Interior Design.

c. American Institute Of Architects (AIA) Biennial Awards Program For Distinguished Architectural Achievement. NAVFACINST 506I.6. An entry submittal is required.

d. Commander's Certificate of Commendation is granted for outstanding performance by a firm whose performance is significantly in excess of contract requirements, based on nominations from the Commanding Officer of Southwest NAVFACENGCOM.

1.4.2 Design Excellence Awards

Recognition for exemplary performance for design services on completed projects within the region, given by the Commanding Officer of Southwest NAVFACENGCOM.

1.4.3 Industrial Incentive Awards Plan

NAVFACINST 4804.3. No A-E entry submittal is required. Nominations are made by the Command.

1.4.4 Certificate of Appreciation

After completion of an exemplary performance by a firm, will be issued and presented by the Commanding Officer of Southwest NAVFACENGCOM.

1.4.5 Competition of the Construction Specifications Institute (CSI)

Entry by the A-E of solicitation packages for which the A-E has prepared the specifications is encouraged. Applications are available from the CSI Specifications Competition Coordinator, Code 5716, at EFD Southwest NAVFACENGCOM.

1.4.6 Other Awards

The A-E must obtain written permission to submit projects under the Command contract administration for publication or for other awards program. The A-E shall submit the proposed text and/or a complete description of the other awards program.

1.5 A-E EVALUATION

1.5.1 A-E Performance Evaluation

The performance of the A-E will be evaluated at the completion of the design and at the completion of construction. The evaluation is used in the selection process for future projects and is available to all Government Contracting Agencies.

1.5.2 Interim A-E Evaluation

In addition to the final performance evaluation, an interim A-E evaluation may occur for unsatisfactory work or performance. An interim evaluation allows for response and opportunity to improve performance prior to the final evaluation.

NOTES

CHAPTER 2. GENERAL PERFORMANCE REQUIREMENTS

2.1 GENERAL

The Architect-Engineer (A-E) has the responsibility to ascertain what information is available from existing Navy records and what assistance can be provided by the Navy. It shall be the responsibility of the A-E to obtain all additional information necessary to accomplish the work. Exceptions to this requirement are as stipulated in Chapter 3, Paragraph: "Field Investigations".

2.2 STATEMENT OF ARCHITECT-ENGINEERING SERVICES

Attachment A of the Contract is furnished to the A-E prior to fee negotiations. The Statement of Architect-Engineering Services will be the basis for negotiation of fee and resulting formal contract. **The A-E must restrict actions to the negotiated Statement of Architect-Engineering Services.** The Statement of Architect-Engineering Services sets forth:

- a. Project Scope in terms of facility description.
- b. Construction Cost limitation
- c. Basis of A-E effort in terms of services to be provided.
- d. Schedule of submittals.
- e. Special considerations.

2.2.1 Deviations And Changes In The Statement Of A-E Services.

Any deviation from the Statement of Architect-Engineering Services must be discussed with the PL and approved by the Contracting Officer prior to A-E performance. Where a change in A-E services is justified, the Contracting Officer will issue a Contract Modification to the "Statement of A-E Services", and following successful A-E negotiations will issue a formal contract modification.

2.2.2 Precedence

In the case of conflict between the "Statement of A-E Services" and the A-E Guide, the Statement of A-E Services shall govern. The A-E Guide shall govern over its referenced criteria. Conflicts between the contract documents shall be promptly brought to the attention of the Contracting Officer for clarification.

2.2.3 Quality Assurance

The basic A-E responsibilities are identified in MIL-HDBK-1006 and the following A-E Contract Clauses. **Special attention is directed to the FAR clause 52.236 entitled "RESPONSIBILITY OF THE ARCHITECT-ENGINEER CONTRACTOR (APR 1984)" and**

to the NAVFAC clause 5252.236 entitled "GENERAL STATEMENT OF A-E SERVICES" of the A-E Contract Clauses.

2.2.4 A-E Quality Assurance

The contractual obligation of the A-E to provide professional quality, technical accuracy, and coordination of all designs, specifications and other services is extremely important and has far reaching consequences. Ambiguity, omissions, and uncertainties on construction contract drawings and specifications generally result in higher bids and field change orders. Liability for design errors and omissions will be pursued. An independent thorough check by the A-E shall be accomplished on all plans and specifications and other required data prior to any scheduled review. This independent Quality Assurance review shall be for the purpose of eliminating errors, interferences, and inconsistencies between all design disciplines, inconsistencies between drawings and specifications, and for the incorporation of criteria, review comments and guide specifications, as appropriate.

2.2.5 Command Review

The Command does not provide detailed checking or coordination services. A-E submittals will be reviewed by the Command only to the extent necessary to establish conformance with the authorized statement of A-E services and applicable Navy design criteria, and to establish reasonable assurance that work can be completed within funds authorized. The A-E shall accept full responsibility for the technical accuracy and professional quality of all work and material which are furnished under a contract with the Command.

2.3 LIAISON BETWEEN A-E AND THE COMMAND

The A-E shall designate an individual who will be directly responsible for the contract. The Command will assign a Project Architect (PA)/Project Engineer (PE), Activity Civil Engineer (ACE) and a Contract Specialist. Technical liaison between the A-E and the Command will be through the PL. Contractual liaison shall be through the Contract Specialist.

2.4 NOTICE TO PROCEED

The A-E is authorized to proceed with the work only upon receipt of a written contract or Contract Modification issued by the Contracting Officer.

2.5 PROJECT COST LIMITATION

The A-E shall promptly notify the Contracting Officer in writing if it becomes evident that the project being designed will exceed the project cost limitation, or the estimated cost of construction. (Also see Chapters 8 & 9 - Additive Bid Items.)

2.6 REVIEW COMMENTS

2.6.1 Review Comments Resolution

The A-E is responsible for the resolution and incorporation of government comments into the project design. The A-E, after reviewing and incorporating comments, shall return a copy of the comment sheet Exhibit 2-A to the PL, annotated in the right hand column (clearly if hand written) to indicate action taken, as well as returning any marked sheets with annotated responses. The response shall include one of the following two (2) standard responses plus clarifying remarks explaining the rationale for the choice.

- a. Agree with comment. See sheet/detail number for change. (This notation indicates the comment will be incorporated as recommended.)
- b. Disagree with comment. Provide the name of PL and date contacted, and state reason for nonconcurrency. (If already covered in the design please state location.)

2.6.2 Review Comment Presentation Options

At the option of the PL the other methods of review comments and resolution of the comments can be one of the following presentation methods:

- a) Automated Review Management System (ARMS): The ARMS program provides a management tool for the collection, resolution and storing of comments generated during the design/construction of a project. The program can be accessed and installed through SPECSINTACT CD ROM, "Disk C". Developed by Construction Engineering Research Laboratory and the Army Corps of Engineers, Sacramento District.
- b) Design Review Comments (DRC): The DRC program also provides a management tool for the collection, resolution and storing of comments generated during the design/construction of a project. Developed by Chesapeake EFA and distributed by the PL.

2.7 TECHNICAL ADMINISTRATION AUTHORITY (PROCEDURES I & II)

Contract administration will be designated Procedure I or Procedure II in the Statement of A-E Services.

2.7.1 Procedure I

The COTR is the prime contact point for the Government on all technical matters. **The A-E is cautioned to perform no work relative to the contract without written authorization of the Contracting Officer.**

2.7.2 Procedure II

Authority for the technical administration of A-E contracts is delegated to the Activity ROIC. Development of the scope of work, selection of the A-E, negotiation and award of the A-E contract, negotiation and award of changes will be on the same basis as Procedure I. The A-E will submit invoices to the ROIC. After contract award, liaison with the A-E will be by the ROIC through the RPDE at the specific Station. Changes in the Statement of A-E Services may not be authorized at the Station level under PROCEDURE II. When required, a change in the Statement of A-E Services will be approved by the OIC and a modification to the A-E contract negotiated and issued by this Command.

2.8 CONTACTS WITH COMMERCIAL UTILITIES

The A-E, if necessary for the design of the project, shall contact appropriate utility company representatives to determine the source, location and characteristics of the required utility service. Any such contacts shall be coordinated through the PL and shall be made on an information basis only.

2.9 BASE PASSES & SECURITY CLEARANCES

The PL will facilitate the issuance of base passes. The PL will also facilitate visits to classified areas and security clearances to handle classified material if required.

2.10 PROJECT DOCUMENTATION

The A-E shall provide a written report of all conferences, telephone conversations, progress reviews, special meetings and site visits within ten (10) days to the PL. All items affecting contract terms shall be sent to the assigned contract specialist. All correspondence shall reference the project title, project number, location and the A-E contract number. When submittals or similar bulky items are forwarded under separate cover, a copy of the forwarding letter or any related correspondence shall be included in the package.

2.11 A-E RELEASE OF INFORMATION PROHIBITED

The A-E shall not release any information pertinent to a project under design or construction for publication, public speeches, or in any other manner without first obtaining clearance and a release in writing from the Command. All material for which clearance is desired shall be submitted in duplicate. During the bidding period, all requests made to the A-E by prospective bidders for clarification or intent of drawings and specifications and all questions relative to bidding forms, bonds and contract forms shall be referred to the Command telephone number contained in the "PRE-BID SITE VISITATION" paragraph of the specification documents. The A-E shall provide no information to bidders.

2.12 AVAILABLE SITE INFORMATION VERIFICATION

All available documentary information at the Command relative to existing conditions at the site of the construction will be made available to the A-E by the PL. Site information not available at the Command should be obtained by the A-E from the cognizant activity Public Works Office or Public Works Center. **It shall be the A-E's responsibility to thoroughly research and verify all available information and data relative to site conditions so that unexpected interferences will not occur during the construction of the facility.** Single copies of all pertinent and available Command drawings may be ordered from Plan Files and Technical Records through the PL at no cost.

2.12.1 A-E Verification.

It is the A-E's responsibility to evaluate and verify all information obtained from existing drawings even if marked "As-Built" or "Record Drawing" and make visual inspections and field measurements as necessary to properly prepare construction drawings.

2.13 REQUESTS FOR INFORMATION

2.13.1 Bid Inquiries.

Bid inquiries, in the form of Requests for Information (RFIs), that relate to possible error, omission, or ambiguity in the bid documents will be provided to the A-E for resolution. The A-E is required to provide a prompt and clear response to all such inquiries. When response to such inquiries is required by a formal amendment to the bid documents, the A-E is to prepare the amendment and associated cost estimate in accordance with Chapters 8 and 9 of this Guide. The A-E is not to discuss bid inquiries with other than designated Command personnel.

2.13.2 COR.

After award of the construction contract, inquiries that relate to possible error, omission, or ambiguity in the bid documents may be provided to the A-E for resolution. If field changes, the A-E may be required to prepare a formal Change Order Request (COR) package to be used by the ROICC in effecting a unilateral or bilateral modification to the construction contract. The A-E is to prepare the COR package and associated cost estimate in accordance with Chapters 8 and 9 of this Guide.

2.14 A-E COMMUNICATIONS DURING CONSTRUCTION

Throughout the construction period, the A-E shall communicate with the PL and ROICC on technical issues. There shall be no direct communication between the A-E and the Construction Contractor except in those specific instances when the Command may authorize such communication to facilitate the solution of a construction problem.

DESIGN COORDINATION AND REVIEW-COMMENTS
 SOUTHWESTNAVFACENGCOM 11012/1A SAMPLE

JOB ORDER NO.
 540012

COMMENTS BY BOB HELPFUL		CODE 402	PHONE 532-1234	DATE Jan 31, 1995
PROJECT TITLE AND LOCATION UEPH P-230 NAS-SAN DIEGO, CA				TYPE OF REVIEW
			X	45%
				100%
				FINAL
				OTHERS
DWG. NO. OR PAR. NO.	COMMENTS (MAKE GENERAL COMMENTS AFTER SPECIFIC COMMENTS)		REVIEW ACTION (reasons where significant)	
GEN	1. Seismic bracing for mechanical & electrical elements should be provided in accordance with NAVFAC P-355 Sec. 8 and Appendix H. Further information with NAVFAC P-355 Sec. 8 and appendix H. Further information contained in P-355.1		AGREE SEE NOTES ON S-1 & NEW DETAILS 4/S2/S2	
S-1	2. List all design criteria and seismic coefficients used. List soil bearing data and material specs. of structural materials.		AGREE SEE ADDED NOTES ON S-1	
S-1 DET. 11	3. Specify a minimum opening size for detail on left to be applicable.		DISAGREE DETAIL 2 APPLIES TO OPENINGS OF ALL SIZES	
S-1 DET. 17	4. Where is this connection to be used?		AGREE REFERENCE BUBBLE CORRECT TO READ 17/S1/S2	
	5. Check for deflection of 8" slabs over lounge areas.		DISAGREE SEE ATTACHED LETTER FOR DISCUSSION	
S-2 TYP.	6. Due to irregularities in areas and support conditions, it is suggested that C.I.P. concrete be considered for the lounge areas and possibly for corridors, storage, linen, and telephone areas.		DISAGREE AN INAPPROPRIATE SOLUTION. SEE ATTACHED LETTER FOR DISCUSSION	

EXHIBIT 2-A

NOTES

CHAPTER 3. ENGINEERING SERVICES

3.1 GENERAL

Engineering Services (ES) studies, investigations, surveys and reports requiring a wide range of specialized engineering expertise may be required by the Statement of Architect-Engineer Services.

3.1.1 A-E Proposed ES

If an engineering service is not required by the Statement of A -E Services and is later determined to be necessary by the A-E, the A-E shall submit to the assigned contract specialist a statement describing the additional work.

3.1.2 Field Surveys

Survey parties and other A-E field representatives shall report to the activity Public Works Officer or the designated representative immediately prior to commencing a field survey.

3.2 DESIGN QUALITY CONTROL PLAN (DQCP)

The heart of A-E Quality Assurance is the Design Quality Control Plan. It is the outline of how the A-E will ensure that the design fulfills the functional requirements, meets the criteria, and depicts the functional intent through carefully coordinated and completed drawings and specifications. The command will review the plan. The DQCP outlines the A-E Quality Control (QC) process throughout the design for each specific project, and for each phase of work, from the Preliminary Project Engineering Submittal to the Final Design Submittal. As a minimum, the DQCP shall include the following:

- a. The Project Title, P-Number, and Fiscal Year.
- b. The specific method used to cross-check all of the various disciplines' plans to one another for completeness and accuracy at each submittal stage. This method should include the marking system as detailed in 7.1.1.
- c. The specific method used to cross-check the plans and specifications to each other for completeness and accuracy at each submittal stage. This method should include the marking system as detailed in 7.1.1.
- d. The specific method used to determine the constructibility of the facility as detailed in the plans and specifications.
- e. A combined checklist or separate checklists covering the topics listed in 3.2.1 a, b, and c.

- f. The name of the principal or individual within the A-E firm responsible for quality control.
- g. A separate checklist for items that should be researched during the field investigation effort. This checklist should be almost checked off by the time the DQCP is submitted.

3.3 FIELD INVESTIGATIONS

The A-E shall obtain all necessary field data and make site investigations and studies, incidental to the proper accomplishment of the work required under the contract (See Paragraph 3.2.g for checklist requirements). **All information of record relative to existing conditions at the site of construction shall be verified by on-site investigation.** The A-E shall investigate all existing systems including utility systems (water, gas, electrical, storm and sanitary sewer, steam, fire alarm, etc.) with respect to the additional loads to be imposed by the contract project and interfacing of the new requirements with existing systems. The findings and conclusions of all pertinent investigations shall be included in the design calculations. The A-E shall be responsible for design of improvements at and contiguous to the project site to remedy minor deficiencies in existing systems that affect the new work. The A-E's responsibility is limited to the nearest points of connection to the existing utility mains or primary services. The A-E shall promptly notify the Contracting Officer if additional utility studies or special field tests are considered necessary to assure firm engineering conclusions as a basis of design.

3.4 SURVEYS

The A-E shall:

- a. Make all field surveys required for design and development.
- b. Contact the Command to obtain survey control information before beginning any survey work.
- c. Provide surveys of sufficient detail to permit the establishment of finish grades and to show all existing structures, pavements, utility lines, obstructions, etc., within the limits of work.
- d. Include drainage areas, connections to existing roads, size of existing utilities and data required to correct new utilities to the nearest source of adequate supply in field notes and survey drawings. (If greater than five acre, 2 hectare, 4047 square meters see Chapter 7.2.2.1).
- e. Submit completed survey drawings and field notes with the 15% Submittal or the Preliminary Project Engineering Submittal for review and record information.

- f. A-E must contact the design code or surveyor for horizontal and vertical control for each project.

3.4.1 Survey Monuments

The A-E will install a minimum of two concrete monuments with brass caps, within the limits of work, see Exhibits 3-D. Monuments shall be visible from each other for future horizontal and vertical control. Monuments are to be set, so they will not be destroyed during construction. All monuments will have both horizontal and vertical control indicated on them based on station data. Horizontal and vertical control maps for the activity will be provided to the design A-E by the Command. Details of the monument in electronic media can be provided through the Command in DWG or DGN format.

3.4.2 Aerial Surveys

When the A-E uses aerial survey methods and material quantities are to be computed from the survey, the A-E will field verify the area where the quantities are to be computed by manual survey methods. Natural ground will be shot to the nearest one tenth of a foot. Concrete and paved areas will be shot to the one hundredth of a foot.

3.4.3 Cadastral Surveys

This service includes surveys to establish metes and bounds for legal descriptions for real estate holdings and for acquisition of new easements and real estate.

3.4.4 Hydrographic Surveys

This service includes the sounding of waterways or borrow areas either with an electronic echo sounder or with a lead line. It may also include the plotting of the soundings and the computations of quantities.

3.5 GEOTECHNICAL INVESTIGATION

NAVFAC Design Manuals DM-5 and MIL-HDBK-1005 series, DM-7.01, DM 7.02, DM 7.03, MIL-HDBK-1021 and the DM-21 series apply. The A-E shall be responsible for the comprehensive research, investigation, and data collection on all soil and subsurface foundation conditions relative to the project site, for the evaluation of such data and for the formulation of recommendations requisite for project design development. Subsurface investigations shall include but not necessarily be limited to the obtaining of borings and samples, thorough visual inspection, laboratory testing and the documentation of these investigations by written report.

- a. When soil borings are necessary, the borings should be within the foot prints of structures, utility corridors and pavements. The number of borings and their depth

shall be sufficient to obtain data for selection of foundation systems, paving, utilities and other supporting facilities.

b. The A-E shall be alert for any evidence of possible chemical contamination on the site and, as a minimum, conduct field evaluation of each boring sample with equipment capable of detecting petroleum product contamination.

c. If conditions are discovered which require more investigative effort than was anticipated at the time of contract negotiation, it shall be the A-E's responsibility to immediately notify the Contracting Officer and recommend in writing such additional sampling, tests or studies as required to ensure the adequacy of the site and foundation data obtained for the project design.

d. After completion of borings, holes shall be backfilled and ground surface including pavements restored to the original condition, unless more stringent local codes, monitoring of water levels are required.

3.5.1 Soil Testing And Earthwork Standards

Soil testing shall include basic physical properties tests to fully characterize all major soil units as well as design parameter tests appropriate for alternative foundation systems and all supporting facilities. All soil testing shall be conducted in accordance with standard ASTM methods or other procedures as approved by the Command. Borings are to be tested to the extent required to ascertain the general corrosiveness of the site. Test results shall be presented in the manner recommended by the approved procedure or standard and clearly indicate the procedure used by the testing laboratory.

3.5.2 Boring Logs

A complete record of each test hole shall be maintained. The records shall include the boring location, ground elevation of existing surface in reference to an established project datum, a description of the character of the materials encountered (i.e., classification by visual examination and an indication of the conditions in place), elevations or depths of changes in material types where encountered, the elevation and date of the ground water level when first encountered, the elevation of the ground water level at least 24 hours after completion of the boring, and any other unusual ground water conditions. The vertical extent of any visual observations or measurements of probable chemical contamination shall be indicated and described. The record shall include the date on which borings were made, project identification, complete driving records for the casing and sampler indicating the number of blows per foot or fraction of a foot penetration, the weight and height of fall of the hammer used for driving the casing, the weight and height and fall of the hammer, if used, for driving the sample, the size of casing used, and the size and description (manufacturer and model) of sampler for both undisturbed and disturbed samples. Boring logs shall be prepared in accordance with or similar to the sample contained in Exhibit 3-A, reflecting basic soil information and descriptive legends as shown in Exhibits 3-B and 3-C,

and classification of soils and bedrock in accordance to the systems contained in Design Manual DM-7 series. The A-E may use other forms for boring logs provided they contain all of the required information as shown on the exhibits. Lettering on boring logs shall be 0.156 inch (4mm) high minimum.

3.5.3 Report

The results shall be completely recorded, analyzed and presented in a comprehensive technical report which shall contain the necessary recommendations for site grading, foundation design, resolution of related geotechnical problems and, if applicable, a cost comparison of foundation systems. The report shall include a map showing the location of each boring in reference to the lines of the proposed structures, to coordinates, to existing structures, or to other features which are readily identifiable on station maps, a record of each hole in graphical form and test data of all samples, tabulated and clearly presented. To facilitate Graphics Engineering and Mapping Systems (GEMS) input, the station coordinates of at least three (3) reference points (structures) should be included in the boring location plan. The report shall identify soils and bedrock classifications and testing systems used, and results of secondary testing such as consolidation, tri-axial shear and other testing. The report shall describe existing surface and subsurface conditions at the site including both physical and chemical observations of soils during field sampling and laboratory testing. Include in the report the locations of the cathodic protection soil tests/survey, method/description of testing, findings, and recommendations. Graphs, formulae, references, pertinent computations and other information shall also be included in the report. The report shall include a description of the equipment and procedures used during the field investigation for sampling and classification of the logged soils. Sampler description shall include inside and outside diameters and driving procedures used for each type of sampler employed.

3.5.4 Geotechnical Review Certification

When a geotechnical investigation is included as part of the design package the project drawings and specifications shall be reviewed by the responsible geotechnical engineer. Geotechnical review shall consist of a written statement from the A-E stating that the submitted 100% Design Plans and Specifications appropriately incorporated the geotechnical consultants recommendations. The certification shall reference the soil reports containing the recommendations utilized in the project design. The certification shall also include a signed statement from the A-E civil/structural engineer responsible for the design that he/she has reviewed the recommendations contained in the referenced soils reports and incorporated the same into the project design. Include a rationale for any deviation from the proposed Geotechnical recommendations.

3.6 SITE SEISMICITY

Certain types of structures may require the development of specific seismic ground motion criteria for use in dynamic analysis. This site specific criteria is required for all designs that

require dynamic analysis or when specifically called for in the statement of Architect-Engineer Services. Refer to Section 6.8 for design criteria establishing the need for dynamic analysis. Site specific criteria is also required for all designs that require classification of site soil coefficient in accordance with UBC Table 16-J. Structures, such as hospitals and other important use classes as designated in the Statement of Architect-Engineer Services, shall follow the suggested procedures outlined herein. The procedures recommended are intended to promote a more uniform approach for establishing ground-motion criteria and not intended to limit the method considered appropriate by the A-E in the design of earthquake-resistant structures.

3.6.1 Procedures For Developing Seismic Ground Motions

Ground motion for the site will be determined by the A-E using established probabilistic and/or deterministic methods. The procedure used shall be as prescribed in P-355.1 chapter 3 or another method approved by the Command's Senior Structural Engineer.

3.7 ENGINEERING DOCUMENTATION

Beginning with the FY 98 MCON program, **the formal PEP process is being eliminated. This change came too late to affect this edition of the A-E Guide.** An amendment to this guide describing this process change will be issued in the near future. In brief, the Cost Certification is being replaced by the Parametric Cost Estimate (PCE). The PCE does not involve any design since it is the intent of the PCE to produce a budget estimate for MCON projects. The PCE will be due in March every year which is earlier than the PEP was due and will result in the budget information being delivered in time for a critical phase in the budget cycle. For complex projects such as medical facilities, treatment plants, or environmentally sensitive projects, early starts will be authorized to complete technical studies or environmental documentation. When the final design is authorized on the FY 98 MCONs, these projects will proceed straight through design from zero to 100% or final design/build documents. While there will be periodic reviews in the process, there won't be the long delays that were experienced previously between the 15% completion and the final design start. Many A-E's had complained about this hiatus that will be eliminated with this implementation. The PCE shall be prepared by the PCE IQ A-E Contract or In-House. When the design A-E is involved in the PCE, Southwest DIV will provide training on using the new cost model software that produces the parametric estimate. The A-E scope of work will delineate the A-E involvement in the PCE and will provide special details required for FY 98 MCON projects.

Prepare the following (for MILCON Projects only) as described in the latest cost engineering estimate format guide and submit on 8 1/2" X 11" sheets, stapled at the upper left corner.

- a. Form DD 1391 Plus and DD 1391C.

- b. Primary M² cost development sheet and description of high cost/unusual features.
- c. Executive Summary of Project Design and Construction.
- d. Budget Estimate Summary Sheet (BESS) and Parametric Cost Estimate (PCE)
- e. Project Special Considerations.
- f. Project Design and Construction Data.
- g. Sketches of Vicinity Map, Site Plan, Floor Plans, Building Elevations, and Building Cross Sections.
- h. Land Acquisition Data (Where Applicable).

3.8 ARCHITECTURAL REVIEW BOARD (ARB)

- a. Architectural Review Board (ARB) reviews projects to ensure that architectural aesthetic, functionality, compatibility, and character is maintained at the customer activities in compliance with the Activity's Master Plan and Base Exterior Architectural Plans (BEAP), and that the project is within the cost limitations of the program. The ARB shall be the focal point for aesthetic review for projects. Provisions for the physically disabled will also be reviewed by the ARB.
- b. The review at the end of the programming stage or schematic/preliminary Project Engineering (PE) stage is the means by which the Navy can assure itself of development that is efficient, cost effective and reasonably in harmony with the character and quality of desirable environment. The intent is to provide design guidance in those areas not covered by building codes and design directives. It consists of review by qualified professionals to assure conformance with certain considerations of design that the Navy establishes and administers.
- c. The Architectural Review Board (ARB) is to ascertain that the end products of the design will satisfy the following overall goals:
 - 1. The building is sited properly to provide harmonious, effective vehicular as well as pedestrian traffic.
 - 2. The building is sited to take advantage of the existing utilities to provide cost effective construction of the project.
 - 3. The site planning, including landscape design, is in conformance with the Master Plan and BEAP for the Activity.

4. The Fire Protection System will be addressed to ensure that the Fire Protection Engineering Branch from the SWD Design and Engineering Department has been involved prior to the ARB presentation.

5. The building design, as well as supporting mechanical and electrical systems, shall be cost effective, well planned, clean in appearance and simple in form.

6. The overall architectural design must be appropriate, and attesting to the Naval Facilities Engineering Command policy in providing facilities that are durable in character, timeless, and not trendy in looks. Monumental structures, stylistic, passing fashionable design features are to be avoided.

d. The initial ARB review will take place at the preliminary PE submittal stage, or schematic design submittal stage. The PL will request the A-E to submit design status drawings, basis of design and cost estimates at approximately 15% design completion for review and approval by the ARB.

e. Documents required for the ARB submittal will be as a minimum, the following requirements:

1. A color presentation using felt tip markers, or prisma color pencils on blackline, blue line or brown line print. (Site Plan, and Building Elevations)

2. Site plan showing building footprint on contoured base map. Indicate all utility lines, access roads, paved areas, vehicular and pedestrian circulation paths, and existing adjacent structures.

3. List of all rooms and spaces required for the facility. Indicate net square foot/meter area for each room/space. Indicate total gross square foot/meters area of the facility as proposed by the design.

4. Provide scaled floor plan(s) drawings. Label all rooms/spaces, show all major dimensions. Include footprint of major equipment and furniture required in each space. Indicate Mechanical/room/equipment yard proposed for the facility. Indicate schematic duct work if applicable.

5. Provide scaled building sections. Show floor to floor, floor to roof, and ceiling heights. Indicate materials and construction for floor, exterior walls and roof. Indicate duct space for HVAC system if such systems are proposed for the facility. Indicate major electrical installations when such installations are proposed for the facility.

6. Provide scaled building elevations and indicate materials, finishes, texture and color number as referenced in the BEAP.

7. Indicate Structural, Mechanical and Electrical layout to illustrate the facility design.

8. Collateral equipment list to support the design, and coordinate furniture footprint with the floor plan(s), and associated cost.

9. Cost estimate (\$/SF or \$/SM), see Chapter 9 for requirements.

10. Code Criteria Search, see Attachment C.

f. Disable accessibility requirements of the Americans with Disabilities Act Accessibility Guidelines (ADAAG), and the Uniform Federal Accessibility Standards (UFAS) are to be met in providing access for people with disabilities in buildings and facilities and facilities designed, constructed, altered, leased or funded by the Department of Defense.

3.9 VALUE ENGINEERING POLICY AND GUIDANCE (VE)

3.9.1. Introduction

The Naval Facilities Engineering Command exists to provide products and services that delight our customers. The intent of VE is to enhance our ability to delight our customers by meeting all their needs while conserving their limited financial resources. The objective of VE is to provide the best value. Best value is defined as providing required functions for the least life-cycle cost. VE is not cost cutting by impairing required functions. During the process of developing solutions and evaluating alternatives, the VE/Design team members are encouraged to challenge design standards and criteria which do not appear to add value, enhance the project functions, or reflect current private industry practices.

3.9.2. VE Team Studies

There are several different processes available to us to provide Value Engineering studies.

3.9.2.1. Indefinite Quantity Contracts

These contracts provide the opportunity to conduct Value Engineering Team Studies using any one (1) of three (3) methods. The first two (2) methods consist of multi-disciplined teams of professionals meeting exclusively for the project. The third method is essentially a design charette facilitated by a professional Certified Value Specialist (CVS). All methods require the active participation of the A-E.

a. This is the customary five (5) day study. VE services for this study are normally performed and a report provided within 21 calendar days following the initiation of the study.

b. This study consists of a three (3) day team study and is usually conducted immediately following the 15% Preliminary Project Engineering Submittal. Because the 15% submittal is still very schematic, this study investigates program issues rather than technical details. One of the major advantages to performing an early study is that it helps confirm the program by identifying and clarifying basic functions of the project. It becomes a very important design tool that the User, A-E and Design Manager can use to confirm the needs of the program.

c. The **Function Analysis Concept Development (FACD)** process is exercised at the beginning of the Preliminary Project Engineering Design Phase and typically takes ten (10) days. This is a series of concentrated on-site work sessions with the A/E and their consultant engineers, the Station, the Activity, the EFD/A, Public Works, Regulatory Agencies, and other interested parties under the guidance of an independent professional CVS facilitator. The process uses Value Engineering methodology to help better define the project's function requirements and provide a better understanding of them.

3.9.2.2. A-E Scope Of Work For Value Engineering Services

The A-E scope of work may be written to require the A-E to provide an independent VE consultant to participate with the A-E in the design process. The VE consultant's participation is intended to incorporate the VE's systematic approach of proposing and analyzing alternative solutions. The VE consultant works with design team members as well as others who may not be a part of the design team.

3.9.3. VE Reports

A VE report shall be prepared to document all proposals considered. The report shall include schedule and cost impact information, advantages/disadvantages and justification for all proposals. A final report shall document the disposition of all VE proposals, including comments and recommendations incorporated as VE modifications. VE proposal decisions shall be classified as *accepted, accepted as modified, or rejected*. Life cycle cost estimate information shall be included for all items.

3.10 COLOR RENDERINGS

3.10.1 Color Freehand Renderings

The color rendering shall have minimum overall dimensions of 24" x 16" (610 mm x 410 mm) exclusive of lettering, matting and framing. The rendering shall be mounted under glare reducing glass in a sturdy one inch (minimum) flat top black metal or wood frame. One (1) 16" x 20" (400mm x 500mm) Ektachrome print; one (1) 4" x 5" (100mm x 120mm) color negative and one (1) 2" x 2" (50mm x 50mm) color slide shall be provided of the rendering. A perspective sketch of the proposed rendering shall be submitted to the PL for approval before the final rendering is started.

3.10.2 Color CADD Daytime Renderings

The A-E shall provide the CADD rendering. The rendering shall be mounted in a dark wooden frame with non-glare glass. Provide one (1) 16" x 20" (400mm x 500mm) copy; (1) 8" x 10" (200mm x 250mm) color print; (1) color slide; (1) color negative; and one (1) copy of magnetic media using high density 3 1/2" (90mm) disks compatible with AutoCAD Release 12 or Intergraph Microstation 5.0. For more information, see Attachment B.

3.11 ENERGY CONSERVATION REPORT

MIL-HDBK 1190 Facility Planning and Design Guide; NAV PUB P-442 Economic Analysis Handbook apply. The A-E shall prepare a report addressing the HVAC systems and energy conserving features and techniques to be utilized in the design of the project. The report shall include the building systems energy analysis and life cycle cost analysis. The energy analysis shall focus on all air conditioning and heating design factors such as insulation, building orientation, solar shading, size, type and location of glazing, lighting, day-lighting, types of HVAC systems, and energy recovery equipment. The life cycle cost analysis shall consider construction, energy, maintenance and operating costs. The report shall be used in determining the most energy efficient and cost effective system based on the life cycle cost analysis prior to initiating a fixed design. The report shall support the design decisions incorporated in the final design. If the design is changed significantly, then the energy report shall be redone to reflect the new conditions.

a. The number and types of alternatives to be analyzed will be based on the project information provided in the scope of work. Prior to starting the analysis the A-E shall submit the proposed system alternatives for approval.

b. After approval of the proposed system alternatives, the A-E shall perform a computerized energy analysis for any new or rehabilitated building that is conditioned and exceeds 3,000 square feet (278 sq. m.) of gross floor area. The computer program shall be a professionally recognized and Command approved computer program(s) that integrate architectural features with air conditioning, heating, lighting, and other energy producing or consuming systems, and will perform 8760 hourly calculations. Alternately, buildings with 3,000 square feet (278 sq. m.) and less gross area may be analyzed using the Simplified Multiple-Measure Methods described in Chapter 28, "Energy Estimating Methods" of the ASHRAE, Handbook of Fundamentals.

c. The Design Energy Budget (DEB) for the new construction or major renovation projects are to comply with the Design Energy Target (DET) and Energy Conservation Criteria as provided in Chapter 8 (latest revision) of the MIL-HDBK-1190.

d. The life cycle cost analysis shall be performed using Life Cycle Cost In Design (LCCID) computer program or a program determined to be equivalent.

3.12 COMPREHENSIVE INTERIOR SERVICES FOR FURNITURE AND FURNISHINGS PROCUREMENT

DM 14.01 applies. Provide the following:

- a. Furniture placement plans.
- b. Color selection and coordination of furniture and furnishings.
- c. Furniture and furnishings procurement list including cost estimate for each line item. The list shall include, as a minimum, a cost summary sheet, catalog cuts, supplier summary list and specifications for each item. The furniture and furnishings specifications shall include stock/model numbers, item descriptions, quantities, prices, color, finish of fabrics for each item.
- d. Rendering and other presentation materials as may be required to realistically represent the design concept and color scheme for the interior.
- e. Interior signage and directional plan(s) and specifications.
- f. Revisions to the furniture and furnishings procurement list whenever an item specified is no longer available.
- g. Supervision of the installation and placement of furniture and furnishings.
- h. Professional photographs of completed interiors.

3.12.1 Schedule Of Submittal For Comprehensive Interior Services

Prior to the start of comprehensive interior services, the A-E interior design staff, through the PL, shall meet with the command interior designer to obtain information on GSA catalogs, procurement sources, and procedure. Refer to the Statement of Architect and Engineering Services for quantities of submittals.

3.12.2 Comprehensive Interior Services For Medical And Dental Facilities

Normally, medical and dental facilities require comprehensive interior design services. The interior design for these facilities must incorporate, and coordinate all equipment, furniture, signage and lighting. Specific submittal requirements and submittal schedule shall be as stipulated in the Statement of Architect-Engineering Service.

3.13 MANDATORY PROCUREMENT SOURCES FOR FURNITURE AND FURNISHINGS

The government has mandatory sources for purchase of furniture and furnishings. Command Interior Design staff will provide the A-E the information on mandatory procurement sources, such as General Prison Industries (UNICOR) and General Services Administration (GSA) current contract catalogs. When an item is not available on GSA schedule, the designer shall consult with the government interior designer and provide descriptive performance specifications for such item for procurement by bidding process.

3.14 CONCEPT STUDIES FOR HOUSING REPAIR AND IMPROVEMENT

Housing Repair and Improvement Studies are required to determine the extent of periodic repair and improvements for existing Military Family Housing developments. The studies will cover site development items such as paving, road work, utilities, landscape, as well as the housing unit construction. The services for these studies will generally include extensive field investigations, tabulation of the deficiencies, and itemized cost estimates for each repair and/or improvement work item. The studies with attendant cost estimates will be used by the Housing Management Offices to schedule and budget the repair and improvement projects.

3.15 SITE ENGINEERING INVESTIGATIONS (SEI) AND REPORTS FOR TURNKEY HOUSING AND DESIGN/BUILD PROJECTS

Site Engineering Investigation (SEI) Studies and Reports are used to study a parcel, or parcels of land for potential development for TURNKEY HOUSING and DESIGN/BUILD projects. In the performance of the SEI, the A-E may have to provide a number of specialized studies and reports such as Topographic Survey, Subsurface Soil Reports, Contamination Analysis and Reports, Development Density; Configuration of the Proposed Development; Code Constraints; Environmental Issues and Constraints; Utilities Requirements, Points of Connection; Permits and Administrative Agencies' Requirements; Hydrology and Traffic studies, etc.

3.16 CORROSIVE SOIL AND/OR WATER

For projects specifically for cathodic protection design services or those known to require extensive cathodic protection survey such as large pipeline projects, regulated steel USTs/hazardous tanks or as required by the Statement of A-E Services, provide the following:

- a. Soil and/or water resistivity measurements. (Not required if addressed in the soil investigation).
- b. Variations in soil and/or water make-up, such as texture and PH factor. (Not required if addressed in the soil investigation).
- c. Soil moisture content and normal seasonal variation. (Not required if addressed in the soil investigation).
- d. Structure to soil potential measurements where protection is to be provided for existing underground structures or where buried test specimens are used for new installations.
- e. Insulation flange measurements.
- f. A cathodic protection stray current interference survey, when the new project is in an area known to be occupied by other existing underground utility systems or structures.

Provide and include in a report the location of tests/survey, method of testing, findings, and recommendations.

3.17 OCCUPATIONAL SAFETY AND HEALTH REPORT

3.17.1 Regulations.

Describe any significant design features necessary for compliance with federal and state regulations pursuant to PL 91-596, the Occupational Safety and Health Act of 1970.

3.17.2 Planning And Design For Safety.

In addition to compliance with regulations and codes, develop a facility with layout and accommodations that protect workers from potential hazards in planned operations. Regulations are minimum standards and frequently address worker protection measures under adverse conditions. The Government benefits when facilities are designed for work environments that are safe to operate and manage. Investment in safety during planning and design includes identifying potential user hazards and eliminating or controlling them through appropriate measures. These include selection of alternative means to accomplish facility function, engineering controls, or installation of protective barriers. Elimination of hazards is preferred to long-term management of hazards and mishap consequences. An early submittal is required for major alternatives to facility arrangement. Engineering controls should be submitted during design development. Protective barriers should be shown in plans and specifications.

- a. Determine a plan of action to design for safety. Follow guidance in MIL-STD-882C, System Safety Program Requirements. Estimate additional effort needed and assign responsibilities. Submit the plan in the BOD.
- b. Follow up on available Preliminary Hazard Analysis (PHA), Preliminary Hazard List (PHL), or list of hazards developed for the project. Where practical, eliminate hazards identified as Risk Assessment Code (RAC) 1 and 2. Optimize safety in the facility work environment. State the measures planned which are complex or require significant interdisciplinary coordination.
- c. If additional study is needed, discuss in the BOD and coordinate with the PL.
- d. Attach available PHA, PHL, or list of hazards to the BOD as an attachment.
- e. Track each hazard for possible elimination, control, or protective barrier design. Comply with MIL-HDBK-1001/1, System Safety Engineering requirements and the A-E contractor requirements in NAVFACINST 5100.11H.
- f. In each subsequent submittal, discuss progress and describe design considerations to address safety concerns.
- g. If a PHA is not available for facilities assigned an overall RAC-1 or RAC-2, coordinate with the PL. A safety consultant may be needed. MIL-STD-882C provides guidance for accomplishment.

3.18 ASBESTOS SAMPLES ANALYSIS, REMOVAL AND DISPOSAL REPORT

3.18.1 Facility Changes

Asbestos has been used in over 5000 products associated with building materials. Facilities undergoing changes such as demolition, renovation, repair, retrofit, rehabilitation potentially involve disturbance in the following circumstances:

- a. Construction involving drywall demolition
- b. Spray applied acoustical ceiling material
- c. Work involving decorative paints and walls
- d. Roof repair and/or demolition
- e. Boiler and lagged hot water lines
- f. Floor tiles and adhesive tiles

- g. Linoleum removal
- h. Wall insulation
- i. Plaster & Stucco
- j. Spackles
- k. Caulking putty, millboard and cement insulation
- l. Paints and coating
- m. Various textile materials

The A-E shall make prudent efforts to insure that asbestos detection and evaluation is accomplished in sufficient detail to accurately identify the presence of the material or rule out its existence. The Environmental Protection Agency Model Assessment Program shall be used as the guide in defining homogeneous areas, establishing sampling protocols and providing objective identification levels. Particular attention will be given to the correct identification of damaged asbestos containing material with priority assessment based on the EPA algorithm determining removal, encapsulation and/or repair.

3.18.2 Site Investigation Of Suspect Materials

In cases where demolition is anticipated, friable asbestos material shall be removed before other work proceeds. Preparation for work will include notification of regulating agencies, arrangements to provide proper transportation, verification of personnel and contractor qualifications and assurance that administrative procedures are completed are requirements that must be taken as part of the site surveillance when RACM is present. Additionally, the report submitted after review, during site surveillance to insure thoroughness in the data generated. This will include the facility history file which includes a record history of maintenance and repairs accomplished to date. Record data from NAVFAC MO-321, Facilities Management and NAVFAC MO-322, Inspection of Shore Facilities will be summarized and presented in a table format as part of the summary report.

3.18.3 Regulated Amounts Of Asbestos Materials

Materials that have been objectively identified to contain asbestos are designated Regulated Asbestos Containing Materials (RACM) only if they meet the legally defined identification criteria. Required analysis includes Polarizing Light Microscopy (PLM), Transmission Electro Microscopy (TEM), and X-Ray diffraction. The most commonly used bulk identification procedure is the Petrographic microscopy (PLM). This is currently the legal methodology for bulk sample identification. This method has limitations based on the limit of detection of the light microscope for diameters less than 0.5 microns. The regulated

asbestos containing materials are also defined as fibers of a specific length and length to width ratio as well as percent by area rather than weight per volume. Where identification is other than PLM and insertion of values or identifications by TEM is presented by the A-E, this information must be supplemented with ashed weight data, as well as, fiber size and length for consideration and decision making.

3.18.4 Sampling and Analysis Report

The A-E shall provide a sample and test report complete with proper credentialed signatures and statistical sampling protocols showing sectioned homogeneous areas, square footage, footnotes identifying the logic of establishing the homogeneous areas. This report will summarize the results of the asbestos surveillance and sampling program when completed. A listing of the areas, types and amounts of asbestos found, extent of asbestos contamination, listing applicable federal, state and local regulations applicable, description of procedures to be incorporated in the construction documents for removal, retrofit, repair, disposal and/or encapsulation as appropriate.

3.19 PAINTS and OTHER CHEMICAL COATINGS; SAMPLE ANALYSIS, REMOVAL AND DISPOSAL REPORT

3.19.1 Approved Sampling Plan

Any project involving contact, abrasion, removal, cleaning, or any disturbance of a chemical coated surface will be accomplished only after a definitive analysis of the coating has been made.

3.19.2 Sample Analysis

If the analysis identifies the material as one of the regulated substances such as lead, chromates, organo tins, etc., which are suspected or known to be health or environmental threatening, proper industry accepted work procedures will be initiated.

3.19.3 Work Plan

An approved work plan prepared by a Certified Industrial Hygienist, certified in the Comprehensive Practice of Industrial Hygiene will be employed by the A-E to conduct necessary sampling utilizing a model asbestos approved protocol established in published plans of the EPA. Such plan for sampling will insure with a 95% level of confidence that the materials within a given homogeneous area are consistent with report data for the surface reported. In the case of lead for example, direct readings using X-Ray spectroscopy florescence spectrum may be used. A nominal sixty second test with "K" shell reading may be reported. Unverifiable readings falling between 0.8 to 1.2 mg/cm² will be tested further by obtaining a bulk sample and testing using atomic absorption and/inductively coupled plasma spectroscopy or graphite furnace technology.

3.19.4 Laboratory Analysis

Laboratory analysis will be by an accredited laboratory participating in the Proficiency Analytical Testing program conducted by the American Industrial Hygiene Association.

3.20 ENVIRONMENTAL PERMIT REQUIREMENTS INVESTIGATION, REPORT, PERMIT APPLICATIONS AND CONSOLIDATED COMPLIANCE ASSESSMENT REPORT

3.20.1 Design Compliance

The A-E shall design the project to comply with all applicable Federal, State, Local and Intergovernmental Environmental Protection Standards governing air quality, water quality, solid waste and hazardous waste. The A-E shall design the facility to comply with the most stringent applicable standards.

3.20.2 Permit Application Submittal

The project may require that the government secure permits for pollution control, construction, operation, etc. As required, investigate the need for, report on, develop the required data and design information, and obtain and submit completed draft and final permit applications with supporting documentation to SOUTHWESTDIV. Coordinate all contact with any applicable federal, state, and local regulatory agency through SOUTHWESTDIV. SOUTHWESTDIV will be responsible for submission of the application(s) for the final permit(s) where applicable.

3.20.3 Permit Requirements Report

Project Review, Environmental Permit Checklist, see Attachment D-1, Equipment Requiring Permits (known), see Attachment D-2.

Prepare a Permit Requirements Report which includes the following:

- a. Project Review Environmental Permit Checklist, Attachment D.
- b. Permitting authority (EPA, COE, state, local, etc.).
- c. Type of permit required (construction, operation, discharge, use, dump, dredge, fill, haul, etc.).
- d. Who is responsible for submitting the permit application.
- e. Procedure and time necessary to complete permit application and obtain permit.
- f. Permit fees required.

g. Statement that the project is covered by variances or that the permit is not required. If a variance is required, describe the procedures on how it will be obtained. If a permit is not required, furnish reasons and supporting justification (cite state and local regulations).

h. For each permit required, the A-E shall evaluate all applicable regulations to determine if monitoring devices are needed. Where required, monitoring devices shall be included in the project design.

3.20.4 Consolidated Compliance Assessment Report

The A-E shall prepare and submit a Consolidated Compliance Assessment Report.

3.21 SOLAR ENERGY STUDY

The economic analysis will be performed by the Government, or the A-E as stipulated in the "Statement of A-E" services. The A-E shall provide the following information:

- a. Project Location
- b. Ground water temperature
- c. Average 24 hour domestic water consumption
- d. Hot water supply temperature
- e. Space available for solar panel installation
- f. Type of installation (ground or roof)

If a solar system is determined to be cost effective, a fee for the design will be negotiated. The solar system is to be included in the bid package (drawings & specifications) as an additive bid item.

3.22 SHORT CIRCUIT AND COORDINATION STUDY

This service is to be used primarily on electrical distribution projects. It is not for use on the typical facility design. For the typical facility design the effort is part of the project design and calculations. Determine the short circuit duty required for all protective devices and switchgear and the proper selection and setting of all protective devices to ensure that the electrical system will be properly coordinated. Back-up calculations and time-current characteristic curves must be submitted. The final submittal of relay settings and time-current characteristic curves shall be made when the exact relays, circuit breakers, or fuses to be used are known.

3.23 DESTRUCTIVE TESTING

In those instances where information is needed for a project but it is hidden from view or unavailable due to existing facilities, then destructive testing to gain access to this information is highly encouraged. If it is unanticipated and not included in the current Statement of A-E Services, then the A-E is advised to contact the Contract Specialist to request that this be added as a scope change. Each such request will be considered on its own merit and if adopted will be awarded as a modification to the A-E contract.

3.24 FIELD VERIFICATION PRIOR TO CONSTRUCTION

Reconfirm site conditions which generated the basis of design. Any revision to the design required as a result of this survey shall be made available to the PL.

3.25 DESIGNER TO ROICC REPORT

Identify "critical" inspection features of the project which will assist the ROICC in the development of an effective inspection plan and the assignment of available expertise. The report shall include items such as those outlined in the "Designer to ROICC Presentation" paragraph of this Guide.

3.26 DESIGNER TO ROICC PRESENTATION

This presentation shall be conducted by the A-E design team to orient ROICC personnel who will administer the construction contract. The presentation shall be made at a place and time established by the ROICC office. The presentation shall include a general description of the project, and shall flag critical, unique or special construction features or details. The presentation shall include, but not be limited to the following:

- a. Outline the project scope of work. Discuss the project construction schedule and all phasing requirements.
- b. Explanation of the structural concept, materials, or unusual construction features. Outline critical structural elements, tolerances, special anchors, pile foundations, testing requirements, joint seals, etc.
- c. Outline of specified testing requirements, i.e., pile loading, field tests, etc. Where tests specified are unusual or non-standard, give more detail. Review Log of Submittals and CQC Testing Plan.
- d. Brief description of mechanical, electrical, utility designs and unusual features such as high pressures, temperatures, capacities, etc.

- e. Discussion of critical areas where 100 percent inspection is required (i.e., subgrade preparation, forms/rebar alignment prior to concrete placement, critical structural connections, A/C or HVAC pre-check out requirements, special finish "sample panels" etc.).
- f. Discussion of critical shop drawing requirements.
- g. Discussion of requirements for supervision of installations by the manufacturer.
- h. Explanation of requirements for operating and maintenance manuals.
- i. Outline of the long lead procurement items and Government furnished equipment and the impact that these items may have on the timely completion or coordination of the project.
- j. Explanation of customer operational requirements (i.e., utility outage periods, aircraft runway closures, phasing of work in certain buildings, areas etc.). Refer to the specified requirement.
- k. Discussion on permit requirements.
- l. Outline of hazardous materials and safety precautions (i.e., asbestos, beryllium, lead paint removal, mercury, toxic substances).

3.27 TRAVEL

Local travel is defined as travel within a 50-mile radius of the local A-E office and is not reimbursable. Travel and per diem expenses outside the local travel area must be approved by the PL prior to start of travel and will be separately reimbursed in accordance with provisions of the Standardized Government Travel Regulations. A travel request must be approved by the PL prior to start of travel, providing the date, length of time and name of individual performing the travel. The travel authorization must be approved in writing or, if granted orally, must be confirmed in writing.

NOTES

SOIL BORING LOG KEY

SOIL DATA LOG

GROUND SURFACE ELEVATION _____

DATE: _____

NUMBER: _____

DRY DENSITY (LBS/CU FT)	MOISTURE (% DRY WT)	BLOW COUNT (BLOWS/FT)	CHEMICAL (PIC/PPM)	SAMPLE TYPE	DEPTH (FT)	SOIL LOG	SOIL CLASS	
▲	▲	▲	▲	▲	-	▲	▲	<p>LOCATION: Activity, State, Area EQUIPMENT: Type of rig, casing PROJECT: Proposed facility & no.</p> <p style="text-align: center;">DESCRIPTION</p> <p>Indicate major soil type, color, moisture, minor soil types present, compactness for coarse-grain soils, consistency for fine-grain soils, approximate percentage of cobbles. (see DM 7.1 for further details)</p> <p style="text-align: center;">ATD ¹² ←</p> <p><u>Water table & Time of observation</u> <input style="width: 100px;" type="text"/></p> <p><u>Soil Classification</u> ²</p> <p><u>Graphic Log</u> ² of soil class</p> <p><u>Sampler Type</u> ² for each sample type indicate I.D., O.D., drive method</p> <p><u>Chemical Data</u> ² indicate type of equipment & observed concentration</p> <p><u>Blow Count</u> ³ indicate number of blows used to advance specified sampler per foot or as indicated</p> <p><u>Natural Moisture Content</u></p> <p><u>Natural Dry Density</u></p> <p>NOTES:</p> <ol style="list-style-type: none"> 1. Provide table of time and water level readings if a piezometer installed or boring is left open. 2. Provide separate legend defining classification system, particle size limits, sampler procedures and other graphic symbols used in boring logs. 3. Provide recommended conversion to estimate Standard Penetration Test (ASTM 1586) from the blow counts indicated for each sampler. 4. Indicate start and completion times for each boring.
					5			
					10			
					15			
					20			
					25			
					30			

Exhibit 3-A

TYPICAL SOIL BORING LOG

SOIL DATA LOG

GROUND SURFACE ELEVATION













DATE:

NUMBER:

DRY DENSITY (LBS/CU FT)	MOISTURE (% DRY WT)	BLOW COUNT (BLOWS/FT)	CHEMICAL (PIC/PPM)	SAMPLE TYPE	DEPTH	SOIL LOG	SOIL CLASS	LOCATION: EQUIPMENT: PROJECT:
								DESCRIPTION
					5 10 15 20 25 30			

Exhibit 3-B

SAMPLE SOIL BORING LEGEND

MAJOR DIVISIONS		GROUP SYMBOLS		TYPICAL NAMES		
COARSE GRAINED SOILS (More than 50% of material is LARGER than No. 200 sieve size)	GRAVELS (More than 50% of coarse fraction is LARGER than the No. 4 sieve size)	CLEAN GRAVELS (Little or no fines)		GW	Well graded gravels, gravel - sand mixtures, little or no fines.	
		GRAVELS WITH FINES (Appreciable amount of fines)		GP	Poorly graded gravels or gravel - sand mixtures, little or no fines.	
	SANDS (More than 50% of coarse fraction is smaller than the No. 4 sieve size)	CLEAN SANDS (Little or no fines)		SW	Well graded sands, gravelly sands, little or no fines.	
				SP	Poorly graded sands or gravelly sands, little or no fines.	
		SANDS WITH FINES (Appreciable amount of fines)		SM	Silty sands, sand - silt mixtures.	
				SC	Clayey sands, sand - clay mixtures.	
			SILTS AND CLAYS (Liquid limit LESS than 50)		ML	Inorganic silts, and very fine sands, rock flour, silty or clayey fine sands or clayey silts with slight plasticity.
					CL	Inorganic clays of low to medium plasticity, gravelly clays, sandy clays, silty clays, lean clays.
	SILTS AND CLAYS (Liquid limit GREATER than 50)		OL	Organic silts and organic silty clays of low plasticity.		
			MH	Inorganic silts, micaceous or diatomaceous fine sandy or silty soils, elastic silts.		
		CH	Inorganic clays of high plasticity, fat clays.			
		OH	Organic clays of medium to high plasticity, organic silts.			
HIGHLY ORGANIC SOILS			Pt	Pest and other highly organic soils.		

BOUNDARY CLASSIFICATIONS: Soils possessing characteristics of two groups are designated by combinations of group symbols.

PARTICLE SIZE LIMITS

SILT OR CLAY	SAND			GRAVEL		COBBLES	BOULDERS
	Fine No. 200	Medium No. 40	Coarse No. 10	Fine No. 4	Coarse 3/4"		
U.S. STANDARD SIEVE SIZE							

UNIFIED SOIL CLASSIFICATION SYSTEM

Reference:
 The Unified Soil Classification System, Corps of Engineers, U.S. Army
 Technical Memorandum No. 3-357. Vol 1, March, 1953 (Revised April, 1960)

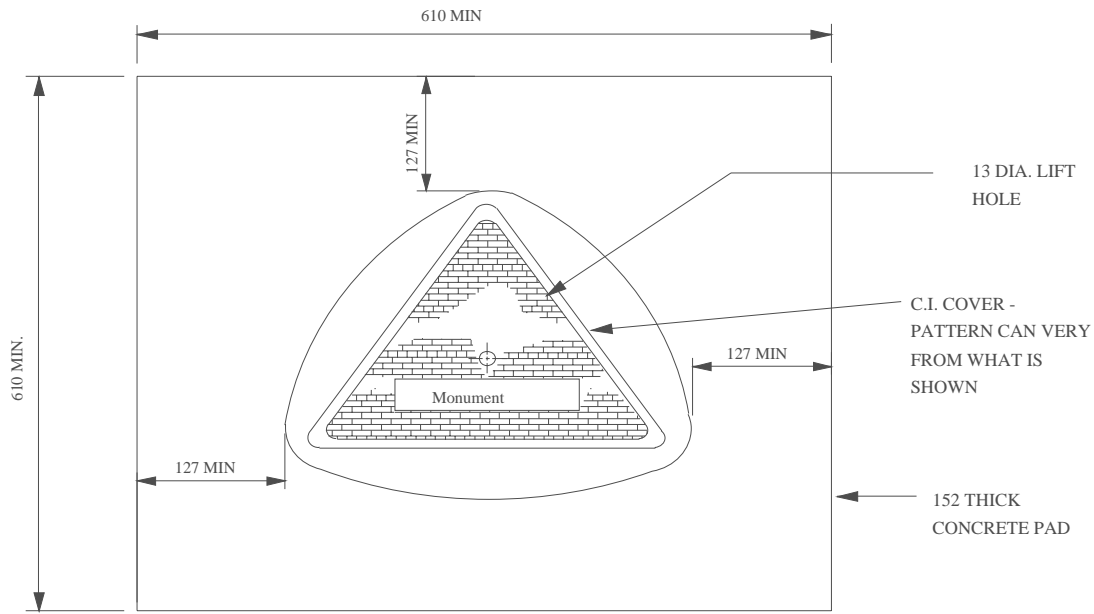

PLAN - IN UNPAVED AREA

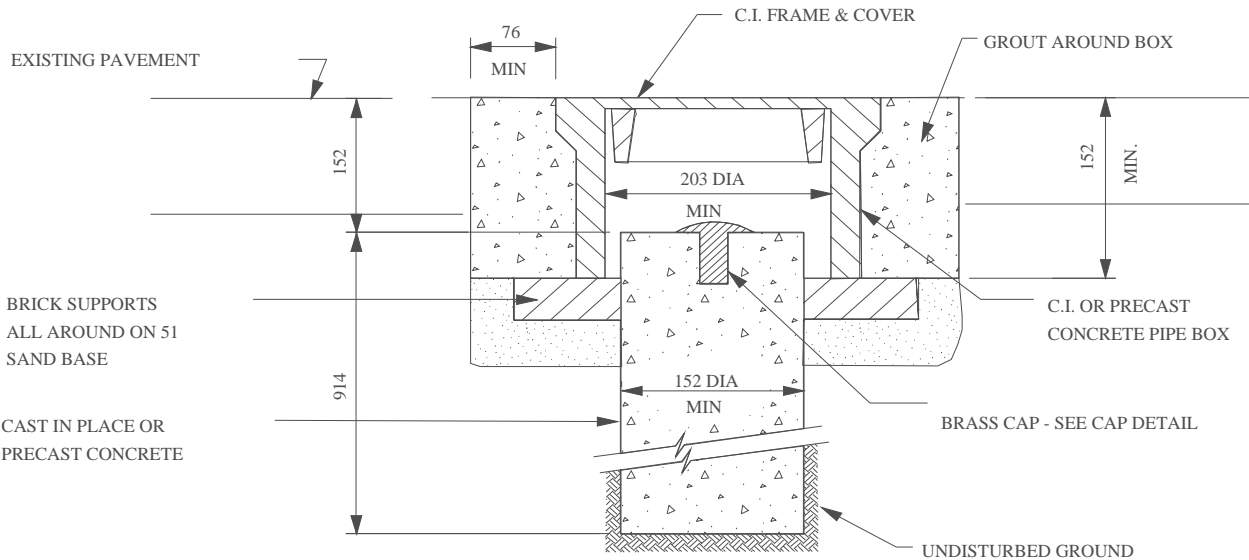

SECTION - IN PAVED AREA

*ALL DIMENSIONS ARE IN MM

STANDARD DRAWING
SURVEY MONUMENT

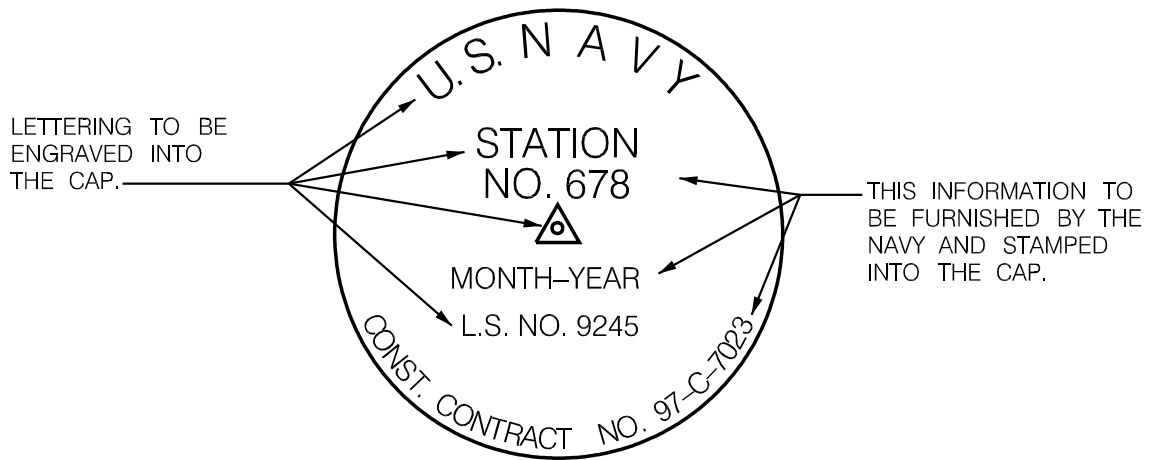

PLAN

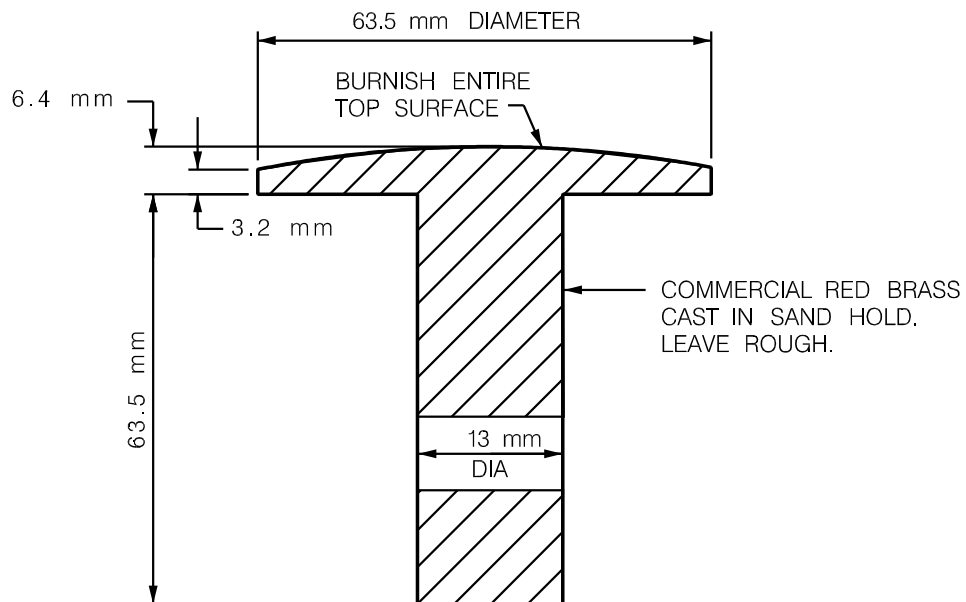

SECTION

STANDARD DRAWING
BRASS CAP

CHAPTER 4. CONSTRUCTION CONTRACT SUPPORT SERVICES

4.1 OFFICE CONSULTATION

The A-E shall be available for office consultation necessary to clarify the intent and interpretation of the plans and specifications, to provide advice on questions that may arise in connection with the construction project and to provide consultation for proposed changes to the construction contract. These services are to be provided to the Resident Officer in Charge of Construction (ROICC) or their representatives and not to the construction contractor. The A-E shall provide a copy of all correspondence between the ROICC and the A-E concerning these services to the PL within three (3) days of receiving or sending such correspondence. All correspondence concerning the construction contract shall bear the construction contract number.

4.2 SUBMITTAL REVIEW

The A-E shall be responsible for reviewing a percentage of the construction contractor submittals as stipulated in the Statement of A-E Services. The specific submittals that will be reviewed will be selected during the design phase of the contract. The A-E will submit a recommended list of submittals to the PL for approval with the 100% design submittal. The percentage of submittals for government (A-E) review will be assumed to be 20 percent if it is not stipulated in the Statement of A-E Services. Where the Statement of A-E Services establishes a submittal percentage limitation for A-E review, the A-E shall review shop drawings and material samples that are sufficiently critical or complex or are aesthetically significant. This review shall insure that the submittal is in compliance with the plans and specifications of the contract. Additional submittals may be identified for review to assist the ROICC in monitoring the construction contractor's quality control. The total number of submittals for review should not exceed the percentage limitation without a contract modification. The remaining submittals will be provided to the A-E for information only and will not require review. Within ten (10) working days after receipt by the A-E, the A-E shall return annotated copies of the submittal with recommendations for approval or non-approval based on compliance with the plans and specifications of the contract. The A-E shall retain one copy for their files and one copy for their consultant. The Fire Protection submittals shall only be reviewed for coordination with the other disciplines and for aesthetics. Refer to paragraph titled "OPERATION AND MAINTENANCE SUPPORT INFORMATION (OMSI) REQUIREMENTS" and NFGS 01730 for additional requirements.

4.2.1 Stamped Notation

The submittal shall be reviewed for compliance with the construction contract requirements and the following stamped notation shall appear on the face of the submittal if space permits. If space does not permit, the stamp may be on the back side of the submittal. On shop drawings, the stamp shall be near the title block or on the reverse side near the title block corner. In using the stamp, the A-E's signature signifies a recommended action. The A-E's signature should be that of a registered architect or registered engineer as

appropriate for the item being reviewed. All copies of the submittal shall be marked identically. Extensive comments should be forwarded by a separate letter. The A-E may assume that recommendations are approved unless advised to the contrary. The A-E shall provide the stamp at A-E's own expense.

COMMANDING OFFICER
[ADDRESS of Contracting Officer]

RECOMMEND:

- APPROVAL
- APPROVAL SUBJECT TO THE CORRECTIONS NOTED
- RETURN FOR CORRECTIONS NOTED AND RESUBMISSION
- DISAPPROVAL

Subject to the requirements of:

Contract No. NXXXXX- -C- Spec. No.

Checked by: (Signature) Date
 (A-E Firm Name)

4.2.2 Responsibility

To Review Designs performed by others. The A-E is responsible for reviewing all designs for conformance to site specific requirements, such as pre-engineered metal buildings, executed by others as part of the construction contract. **Shop Drawings and accompanying designs shall be reviewed and recommended for approval or disapproval by the A-E.** The A-E will stamp and sign these drawings in accordance with Chapter 7 requirements.

4.3 OPERATION AND MAINTENANCE SUPPORT INFORMATION (OMSI) REQUIREMENTS

4.3.1 OMSI Manuals

The following types of manuals, with some typical information required, are included in OMSI packages shown in Attachment E:

- a. User Manual: Construction contractor submittals such as Catalog Data, Operation and Maintenance Data, Test Reports, Shop Drawings, and data prepared, assembled and indexed in a comprehensive manual. It should also

include the Basis of Design, Life Safety implications, and may include medical requirements.

b. Operation and Maintenance Manual: Operation and maintenance information such as the operating information noted above plus normal operating temperatures and pressures, emergency instructions, preventive maintenance plan, troubleshooting guide, maintenance guide, and maintenance and repair procedures. The A-E Statement of Services will indicate the systems to be addressed in the Operation and Maintenance Manual. Depending on size and complexity, systems such as the following may be required to be included:

- Heating, Ventilation, and Air Conditioning
- Direct Digital Controls
- Fire Protection
- Central Refrigeration
- Central Compressed Air
- Fuel Oil Handling and Distribution
- Medical Gases
- Laboratory Gases
- Food Services Equipment
- Commercial Intrusion Detection
- Emergency Power
- Telecommunications
- Airfield Lighting
- Weight Handling, Elevators, and Conveyors

4.3.2 OMSI Types

The level of OMSI will vary with the type of facility or complexity of systems. The type of OMSI required for each project will be noted in the A-E Statement of Services. OMSI packages are identified as the following types:

Type A: Includes the Operation and Maintenance Manual, the User Manual, and Record Drawings. See Attachment E.

Type B: Not Used.

Type C: Consists of the User Manual and the Record Drawings. See Attachment E

4.4 RECORD DRAWINGS

The A-E shall prepare the Record Drawings from the construction contractor marked up construction drawings that show As-Built conditions.

4.4.1 General Procedure

A marked set of construction drawings and the original drawings will be provided to the A-E by the PL. The A-E shall correct the original drawings to show the As-Built conditions as indicated on the marked construction drawings. The A-E shall also incorporate onto the original drawings the written modifications to the construction drawings which were issued by amendment or contract modification. All clouds shall be removed. The notes in the revision block shall remain. All questions regarding interpretation of the changes shown on the marked construction drawings shall be referred to the ROICC. At the request of the ROICC the A-E may be required to use FCDC days to verify the As-Built conditions. The A-E shall forward the corrected record drawings and the set of marked construction drawings to the PL within thirty (30) calendar days following receipt of the marked construction drawings and original drawings.

4.4.2 Computer Graphics Data-Base

For specified projects with computer graphics data-base requirements, see Attachment B, the A-E shall correct the data base drawing files to show the As-Built conditions. The title block and the professional stamp of the original signed drawings of the title sheet and the first sheet of each discipline shall be scanned and inserted into the appropriate data base files to depict design responsibility of the drawings. The revision block where a revision is shown on the original drawing shall also be scanned and inserted in the appropriate data-base files. All other As-Built corrections shall be the same as noted below for the correction of original drawings. The A -E shall forward the corrected data-base files to the PL within thirty (30) calendar days following the receipt of the marked construction drawings.

4.4.3 Correction of Original Drawings

The manner in which the original drawings are corrected shall be as follows: Deletions or superseded portions of the original drawings shall be erased. The final record drawings shall show the actual construction only, except where the original drawing contains portions marked "N.I.C." (not in contract) or where optional methods of construction are shown. No change need be made to those portions of the drawings marked "N.I.C.". The optional methods of construction not used should be crossed out and noted "NOT BUILT". Any previous revision markings and symbols shall be removed from the body of the original drawing. The revision notation in the revision block shall remain. Where an original drawing is modified to show As-Built conditions, the notation "AS-BUILT CONDITIONS SHOWN" shall be entered in the top most available line in the revision block with A-E's initial and date in the space provided. Where no change is required on an original drawing to show As-Built conditions, then the notation "AS-BUILT" shall be entered on the top most available line in the revision block with A-E's initial in the "Prepared by" block and the date in the space provided.

4.5 FIELD CONSULTATIONS DURING CONSTRUCTION

Provide consultation upon specific request by the ROICC or the PL. As a minimum, monthly visits to the construction site by the A-E Project Engineer shall be required.

4.5.1 Field Consultation Report

Immediately following each visit, the A-E shall provide a brief report with findings and recommendations to the ROICC with a copy to the PL. The report shall include names of personnel who provided the service, the dates and length of time on-site and the persons contacted.

4.5.2 Site Access

Shortly after the award of the construction contract, the A-E shall provide to the ROICC, with a copy to the PL, the names by professional discipline of personnel who will be available for field consultations. The A-E shall coordinate site access with the ROICC for each visit.

4.6 EVALUATION OF VALUE ENGINEERING CHANGE PROPOSALS (VECP's)

Provide analyses, recommendations, and cost estimates on VECP's submitted by the construction contractor under the Value Engineering Incentive clause of the contract. The purpose of a VECP is to achieve savings in cost by adjusting the design so as to permit more economical methods and materials of construction and yet maintain the operational, functional and aesthetic integrity of the facility. Submit evaluations in triplicate to the PL within 10 calendar days after authorization to proceed date.

NOTES

CHAPTER 5. SUBMITTALS

5.1 SUBMITTAL REQUIREMENTS

Submit the types and quantities of documents by project design stages as required by the Statement of A-E Services. All submittals will be forwarded with project correspondence referencing project title, project number, location, and A-E contract number. A copy of the correspondence shall be forwarded to the Contract Specialist.

5.1.1 Design Quality Control Plan

5.1.2 15 Percent Design (a)

- Survey Drawings
- Survey Field Notes
- Soils Report
- Schematic
- Project Engineering
- Engineering Documentation
- Energy Conservation Report
- Corrosive Soils Report
- Asbestos Survey
- Geochemical Evaluation
- Solar Energy Study
- Basis of Design Report - (Mandatory for all projects)
- Cost Estimates
- Design Calculations

5.1.3 45 Percent Design (a), (c), (d)

- Resolution of 15% Review Comments
- Environmental Permit Requirements
- Short Circuit & Coordination Study
- Design Calculations
- Basis of Design Report (Revised) - (Mandatory for all projects)
- Drawings
- Outline Specifications
- Cost Estimate

5.1.4 100 Percent Design (a), (b), (c), (d)

- Resolution of 45% Review Comments
- Environmental Permit Requirements
- Designer to ROICC Report

Design Calculations
Interior Finish Board
Exterior Finish Board
Quality Control Check Set
Basis of Design - Updated - (Mandatory for all projects)
Drawings
Submittal Register and Test Report
Cost Estimates
Specifications
SPECSINTACT generated 100% Contract Specifications on Disk
Geotechnical Review Certification

5.1.5 Final Design (a), (c), (d)

Resolution of 100% Review Comments
Designer to ROICC Report
Color Rendering
Original Design Calculations - Updated
Drawings
Specification
Submittal Register and Test Report
Cost Estimate
Original Drawings and Copies
Original Specifications and Copies
Original Cost Estimate and Copies
SPECSINTACT generated Final Contract Specifications on Disk

- a. Provide copies directly to the activity, PWO, PWC, Staff Civil and NCTS. Transmittal shall be in Exhibit 5-A format as appropriate with a copy to the PL.
- b. Provide copies of the 100 percent plans and specifications directly to the ROICC. Transmittals shall be in Exhibit 5-B format with a copy to the PL.
- c. For projects at activities not served by Public Works Center make these submittals to the activity Public Works Office.
- d. For specified projects with computer graphics data base requirements, the A-E shall submit test 3 ½ inch (90mm) 1.44 MB disks consisting of representation of various project data during 45 percent and 100 percent stages, and complete project data base at final stage, see Exhibit 5-C, along with related documentation as required in Attachment B to the contract.

5.1.6 Transmittals

Where the A-E arranges for submittal shipments by AIR FREIGHT, the A-E shall also arrange and be responsible for the shipment and the delivery of the submittal. Originals and master copies shall be hand delivered or forwarded by registered U.S. mail to the PL. All transmittals shall be addressed to the PL by name and Code.

5.2 REPORTS, ENGINEERING CALCULATIONS, FIELD NOTEBOOKS AND MISCELLANEOUS DATA

Reports, engineering calculations, field notebooks and miscellaneous data shall be legible, neatly bound and indexed and include the A-E's name, the project title, project number, location and the construction contract number. The design rationale shall be clearly stated. When unconventional design methods or formulas are employed, reference sources shall be cited. Calculations shall be on 8 ½" x 11", (210 mm x 297 mm) paper, punched, bound and identified with the project title, project number, location, A-E, and construction contract numbers. The Engineering Calculations shall be bound, sealed and signed by a professional engineer by discipline. For calculations requirements see Attachment A.

5.2.1 Computer Documentation

When calculations and graphics include the use of computers, and/or computer graphics systems, the following documentation shall be furnished for review:

- a. All pertinent input and output data with critical items clearly identified.
- b. Definitions of all input and output terminology.
- c. Documentation of the program used including a synopsis of program intent, engineering methods, assumptions, limitations, and applicable formulae.
- d. Description of methods used to verify and check results, including supplemental long-hand computations.
- e. If the computer program was developed or extensively modified by the design firm, then, in addition to the above, a detailed description of previous usage along with other information deemed necessary by the PL to ascertain its validity, effectiveness, and application to the specific project, shall be furnished.

5.2.2 Computer Graphics Documentation

All submitted data shall be clearly marked, sequenced, cross referenced, and identified with program title, computer, date, responsible person, contract title, contract number, and project component analyzed.

5.2.3 Metric Measurements

Metric measurements shall be hard (rationale) metric. If hard metric is not available on certain items, then soft metric can be used.

5.2.3.1 Hard Metric

The term "hard metric" denotes the conversion of inch-pound units to new, rounded, easy-to-use metric measurements.

5.2.3.2 Soft Metric

The term "Soft metric" denotes the mathematical conversion of inch-pounds units to metric measurements with little or no rounding.

5.2.3.3 Metric Requirements

When a project is required to be designed and built using metric units of measurement, the following shall apply:

- a. All measurements and units shall be shown in System International (SI) metric units exclusively. This includes but is not limited to: Linear measurements, area measurements, volumetric measurements, temperature measurements, climate requirements, waterflows, pressure requirements, noise requirements, lighting requirements, structural characteristics, electrical characteristics, plumbing characteristics, HVAC characteristics, equipment capacities, conveyance system ratings, and all power and energy units.
- b. English system measurements shall not appear in reports, drawings, specifications, cost estimating, or any other submissions. However any computer program that requires calculations which is not available in metric will be allowed. The results of the calculations will be converted into metric.
- c. Design must take place using a 600 x 600 mm planning grid. The A-E firm must strive to use as many "hard metric" products as possible, where competitively available. Where metric products are not available, soft conversion to metric is required, (e.g. 2" x 4") will read $(2 \times 25.4 = 50.8, \cong 50) \times (4 \times 25.4 = 116.0, \cong 100)$ 50 mm x 100 mm.
- d. The latest edition of Metric Guide for Federal Construction, NAVFAC Metrication Conversion for Design Planning and Design Criteria, and NAVFAC Guide Specification shall be used as guidance on drawings, specifications and other elements of metric implementation. Additional guidance can be used that is published by the American Institute of Architect (AIA), Metrication of Master Specifications, ASTM E621 and ASTM E380.
- e. All cost estimating shall be done in SI metric units only.

- f. All terminology in the Specifications shall be in SI metric.
- g. All correspondence must contain SI metric units exclusively.
- h. All meeting presentations and discussions of measurements or units must be conducted using SI metric units.
- i. Shop drawings, catalog cuts, and other submissions during the construction phase will be in SI metric units.
- j. All Operation and Maintenance Manuals will be in SI metric units.

5.3 INTERIOR AND EXTERIOR FINISH BOARDS

16" X 20" (400 mm x 500 mm) with samples showing interior and exterior colors, materials and finishes.

5.4 RESUBMITTAL

Some project submittals are received in a condition which makes them unacceptable for review. In these cases, the package will be returned to the A-E for resubmittal along with an explanation as to why the submittal was not acceptable. The A-E shall provide a resubmittal schedule in writing to the PL within two (2) working days after receipt of the package.

NOTES

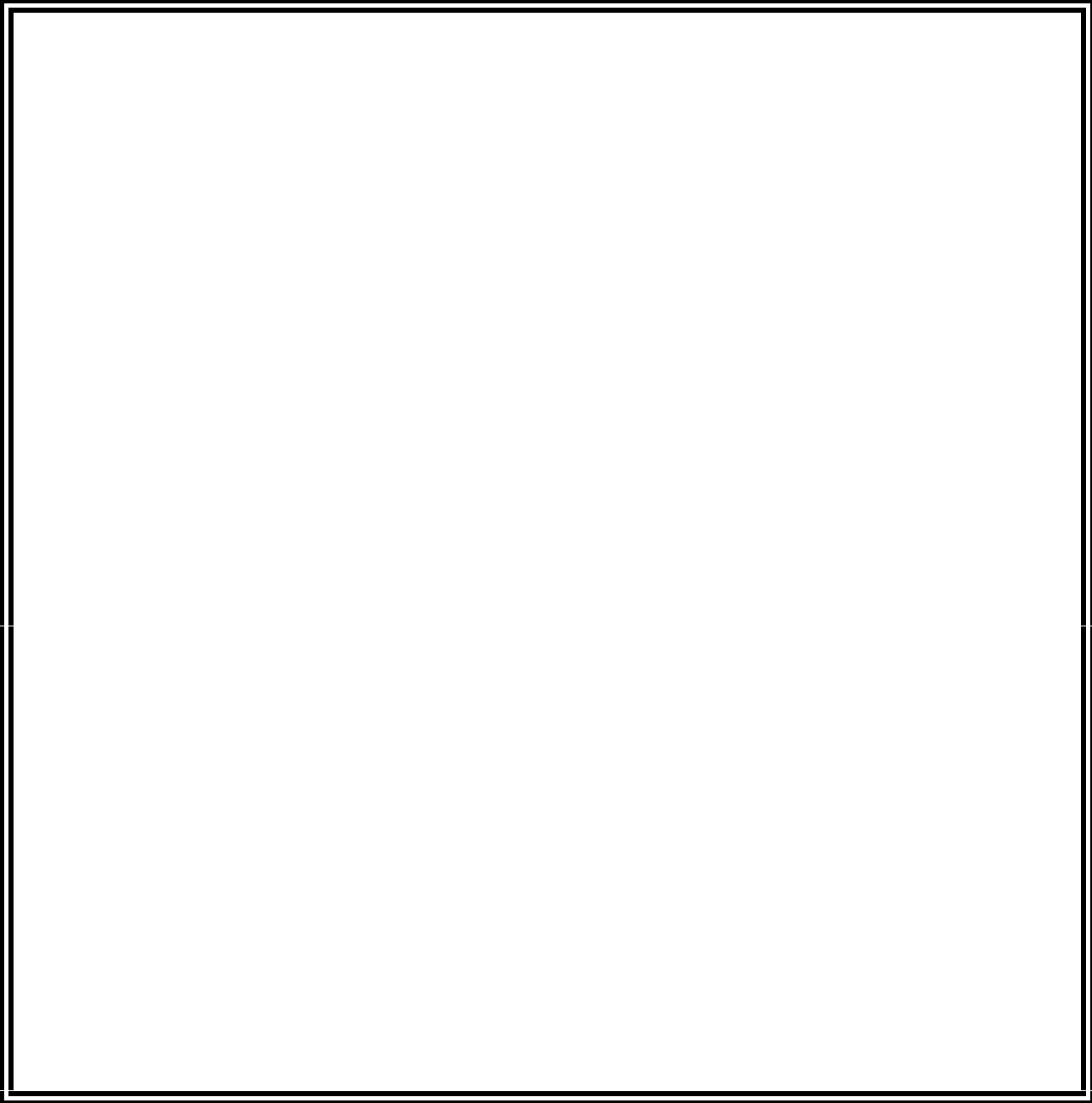

S A M P L E

A-E LETTER HEAD

Commanding Officer
Activity Address

Attention: Code

Dear Sir:

In accordance with the terms of our contract with the [insert Command title] Naval Facilities Engineering Command, for the design of Title , Location , Construction Contract Number NXXXXX- -C- , we are forwarding copies of the [45 percent plans] [100 percent plans and specifications] [Final Plans and Specifications] for your review and comment, please forward review comments to the Design Manager [Insert Name and Address] by [Insert Date].

Sincerely,

Copy to:
COMMAND PL
COMMAND Contract Specialist

Exhibit 5-A

S A M P L E
A-E LETTER HEAD

Resident Officer in Charge of Construction
Address

Dear Sir:

In accordance with the terms of our contract with the [Insert Command Title], Naval Facilities Engineering Command, we are forwarding copies of the 100 percent plans and specifications for the proposed construction Contract No. NXXXXX --C- Project Number, Title, Location. Please forward constructibility review comments on this submittal to the Design Manager [Insert Name and Address] within two (2) weeks.

Sincerely,

Copy to:
COMMAND PL
COMMAND Contract Specialist

Exhibit 5-B

CD ROM Disk Label Format

CD ROM DISKS:

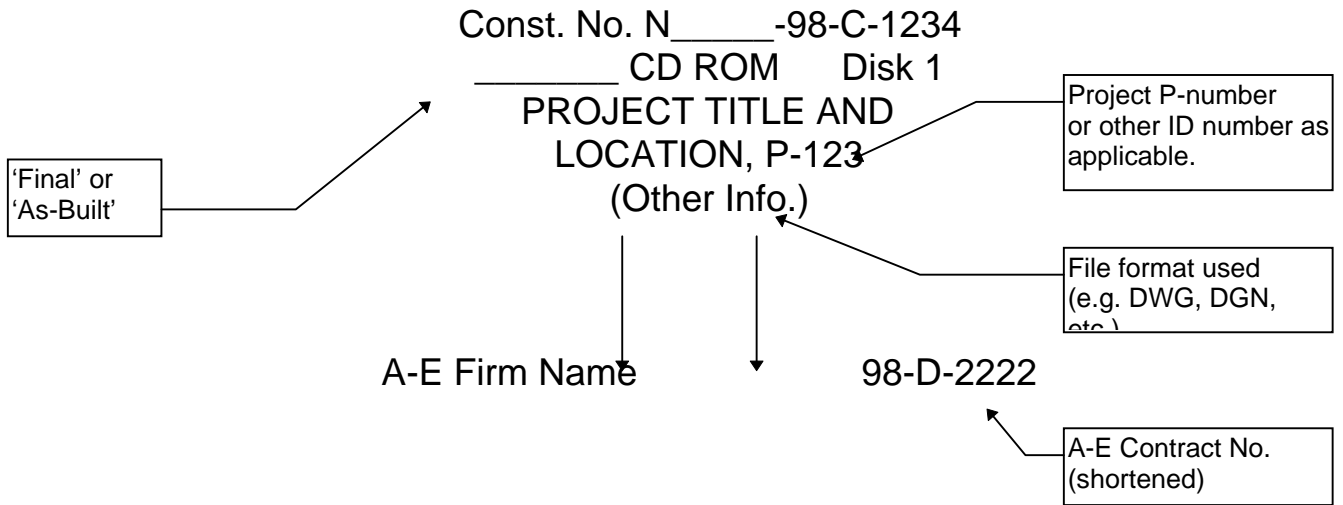

SPECIFICATION DISKS:

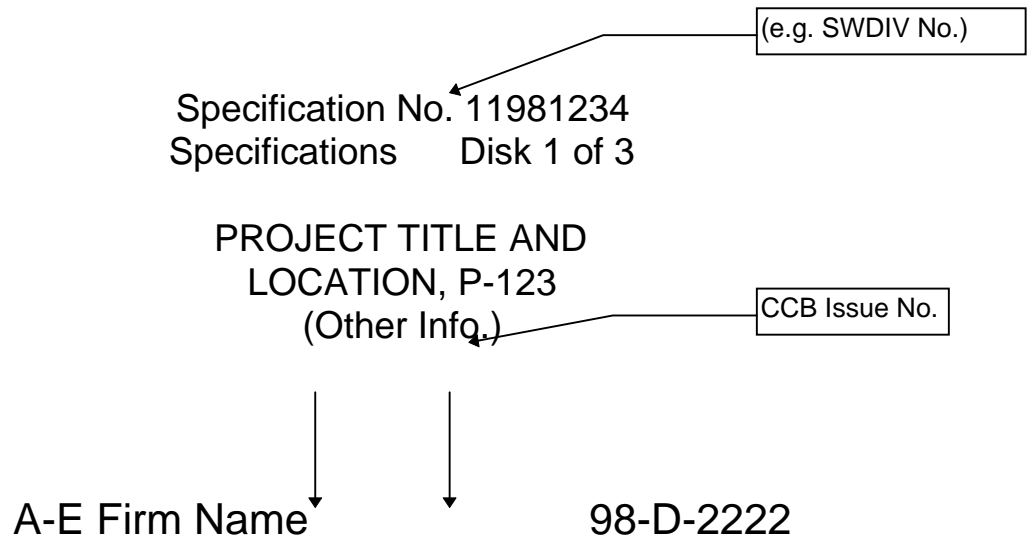

CHAPTER 6. BASIS OF DESIGN REPORT

6.1 GENERAL

This section provides information and requirements for the preparation and submittal of the Basis of Design Report. The Report shall fully describe all project requirements, design solutions and situations affecting the work, as well as justifying proposed departure from standard plans, specifications, NAVFAC technical publications and design manuals or other criteria. Arrange the report in the following order:

- Code Criteria Search
- General Information
- Environmental
- Civil
- Landscaping and Irrigation Systems
- Architecture
- Structural
- Mechanical
- Electrical
- Fire Protection
- Cathodic Protection

6.1.1 Criteria

Identify the governing codes and criteria being utilized for the design. MIL-BUL-34 and the Construction Criteria Base (CCB) provides a listing of those manuals and instructions which apply to most types of facilities normally designed by the Command. Careful attention shall be given to unusual or highly specialized design features for which criteria listed herein may not be applicable. For Air Force, Coast Guard and other agencies, criteria will be furnished as required on a project by project basis.

6.1.2 Computer Graphics

For projects requiring a computer graphics data-base, the A-E shall review with the Command, the up-to-date computer graphics standards and criteria at the outset to assure database integrity. See Attachment B.

6.2 CODE CRITERIA SEARCH

6.2.1 Code Criteria Search

Identify the governing codes and criteria being utilized for the design. The document is used as a basis for the design and shall include: Occupancies Use Requirements; Requirements for Group Occupancies; Fire Resistive Requirements; Planned/Existing Distances; Fire Protection System; Exits; and Interior Finishes. See Attachment C.

6.2.2 Sources Of Design Criteria

Design in accordance with Military Publications, Criteria Manuals, Instructions or Policies. Design that is beyond the scope of these documents shall be in accord with the 1994 editions of the UNIFORM BUILDING CODE (UBC), including the UNIFORM MECHANICAL CODE, the UNIFORM PLUMBING CODE and the UNIFORM CODE FOR BUILDING CONSERVATION.

6.3 GENERAL INFORMATION

6.3.1 Station Master Plan

NAVFAC DM-1.01, Basic Architectural Requirements & Design Considerations, Section 3. Any deviations to the master plan must be explained. The Station Master Plan will be provided by the DM for the A-E's review if requested.

6.3.1.1 Base Exterior Architecture Plan (BEAP)

The BEAP is an addendum to the Station Master Plan and contains site specific design recommendations. The A-E shall follow the recommendations of the Activity BEAP in project design responding to functional and aesthetic requirements.

- a. Describe the design guidelines that pertain to this project and describe how the proposed design incorporates these guidelines into the project design. Explain any deviations.

6.3.1.2 Site Planning

- a. Physical Features. Describe the historic considerations, topography, solar exposure, prevailing breezes, storm exposure, natural beauty of the site, prevalent noise, odors, dust, soil types and possibility of contamination, and a description of nearby buildings at the existing site.
- b. Orientation. Describe how the proposed design takes advantage of or is compatible with the physical features of the site; how it impacts on energy conservation measures; how the design minimizes existing hazards and nuisance effects; and, how the proposed structure(s) harmonize or are compatible with the existing nearby buildings.
- c. Circulation/Traffic Patterns. Describe pedestrian and vehicular traffic patterns as they relate to the building. Estimate building traffic load. Describe shipping, receiving and trash removal requirements.

- d. Describe siting of utilities and where they tie into the existing system. Utilities should not detract from building appearance.

6.3.2 Program Requirements

6.3.2.1 Design Area Tabulation

Provide a complete area breakdown tabulation for gross and net areas to confirm scope and statutory criteria compliance. A supplemental drawing keyed to the area take-off shall accompany the area tabulation. Subsequently revised plans will require area re-tabulation. The project gross area shall not exceed that stipulated by the DD Form 1391.

6.3.2.2 Building Design

- a. Describe the functional requirements of the facility.
- b. Describe persons accommodated, staff size, type and number of visitors.
- c. Indicate the building type of construction based on the latest UBC.
- d. Include a statement as to the consideration and use of definitive, standard designs and previous designs.

6.3.3 Energy Conservation

- a. Describe the proposed energy saving features incorporated in the design and explain the reasons for selecting these items.
- b. Show total annual energy consumption and compliance with the Energy Targets of chapter 8 of MIL-HDBK-1190. Justification/rationale is required if the predicted annual energy consumption exceeds the Energy Target by more than 10%

6.3.4 Weight Handling Equipment

State the need for weight handling equipment and how the equipment is to be designed and procured. The procurement of weight handling equipment of 20,000 pounds and under, associated with a building, or other facility (not including nuclear, hot metals, or special hazard use) is part of the A-E design responsibility. Procurement of weight handling equipment over ten (10) tons and special purpose (nuclear, hot metals, special hazard) is the responsibility of Government. For those cases where the Government is the procurement agency, the A-E shall promptly supply the required operating data and all pertinent field data for weight handling equipment to the PL. An early submittal of this information is required for coordination and timely procurement and installation of the equipment.

6.3.5 Construction Permit Information

Identify information regarding permits necessary for construction.

6.3.6 Physical Security

Describe the physical security or hardening requirements that will be used in the design.

6.3.6.1 Physical Security Hardening

Describe the required physical security hardening, of all projects involving Armories, Arms Rooms, Weapons Storage Facilities, Ready Service Lockers, Terminal Equipment Buildings, Sensitive Compartmented Information Facilities, (SCIFs), etc. These projects shall be designed and constructed in accordance with the minimum criteria of MIL-HDBK-1013/1, OPNAVINST 5530.13A and OPNAVINST 5530.14B.

6.3.6.2 Doors, Windows And Wall Penetrations

The number of doors, windows and wall penetrations within these facilities shall be kept to a minimum. The entrance doors shall be secured with high security locking devices and all windows, wall openings, etc., shall be hardened to resist intrusion.

6.3.6.3 Plans And Specifications

All plans and specifications, incorporating physical security features, shall be reviewed by a host activity security officer/provost Marshall or designated representative, during the design process and various review phases.

6.4. ENVIRONMENTAL REQUIREMENTS

a. The A-E shall identify and determine the necessity for all environmental permit requirements including as a minimum those items identified in Attachment D.

b. The A-E shall provide all technical data required for permit application.

6.4.1 Environmental Assessment/Environmental Impact Statement (EA/EIS)

a. Describe the impact that the new construction will have on the project site environment and habitat as identified in the EIA/EIS.

b. Describe how the design will mitigate the impacts identified in the EA/EIS or describe the requirements the proposed design does not meet and provide justification thereof.

- c. Describe preservation of trees, plants, wildlife, air, water quality, pollution abatement, landscaping and blending of construction with surroundings. The EIA/EIS is normally provided by the Command to the A-E undertaking the design.

6.5 CIVIL ENGINEERING

6.5.1 Site Grading

- a. Describe the drainage of the site.
- b. Describe the differential between finish floor elevations and the finish grades adjacent to structures. Relate finish floor elevation to 100 year flood level.
- c. Describe the earthwork.
- d. Indicate the cut and fill quantities.
- e. Indicate the location of borrow pits and disposal areas and indicate the type of materials associated therewith.
- f. Describe the retaining walls.

6.5.2 Utilities

- a. Describe special utilities including oily waste and salt water systems, etc. outside the building's five (5) foot line.
- b. Identify those systems that need cathodic protection based on the soils report.

6.5.3 Storm Sewer System And Surface Drainage

Use Local Rainfall Intensity-Duration Frequency Curves.

- a. Indicate if the existing system to be connected to is adequate to handle the additional flow. Indicate the source of the information.
- b. State the quantity of storm flow (use rational method) and the sizes, material, class and "D" load design of all storm sewers and culverts and sizes of drop inlets.
- c. Provide a small scale topographic map which depicts the individual drainage areas and their overland flow path.
- d. Indicate the maximum design velocity in unlined ditches.
- e. Indicate design flooding of street gutters under maximum design flow conditions and type of drop inlets to be used.

- f. Indicate minimum diameter of storm drain piping.
- g. Indicate minimum width of concrete cross gutters where surface storm drainage crosses street paving.
- h. State minimum slopes for surface drainage for the following:
 - Grass or turfed areas
 - Paved areas
 - Paved ditches
 - Grass swales
 - Unpaved areas within 10 feet (3000mm) of buildings
- i. Discuss requirements for National Pollutant Discharge Elimination System (NPDES) Permitting for the project locality.

6.5.4 Water Systems

- a. Describe the existing water system, covering particularly the type, capacity, adequacy, condition and present water use.
- b. Describe how the design will minimize or eliminate the unsatisfactory conditions.
- c. Describe connections to existing water distribution systems.
- d. State the type of construction proposed, materials for water mains, type of well, etc.
- e. Describe distribution systems. Provide statement of design, domestic consumption required and available fire flow, residual pressure and elevation differentials. (Include designer's estimate of tentative pipe sizes.)
- f. Indicate the water demand for the project and how it was derived.
- g. Indicate if the existing system to be connected to is adequate to supply this demand and how this was determined. If source is inadequate, state correction measures needed.
- h. Statement of tentative sizes, elevations, capacities, or design consideration for reservoirs, treatment units, pumping plants, well pumps and how they were determined.
- i. Indicate design pump speed and provide pump and system curves.

6.5.5 Sanitary Sewer Systems

- a. Describe the existing sewer system. Indicate if the existing system to be connected to is adequate to handle the additional flow and how this was determined.
- b. Describe the new sewer system, pumping stations, the sewage flow to be generated by the project and how it was derived, quantity of sewage, minimum scour velocity during the peak daily flow, and the sizes and material and type of all sewer lines.
- c. Indicate design depth for underground systems.
- d. Indicate pump design speed.

6.5.6 Sewage Treatment System

- a. Describe the existing system covering particularly the type, capacity, present flow.
- b. Indicate the design capacity and degree of treatment required of the new system and how they were derived.
- c. Indicate how the new system will meet these requirements.

6.5.7 Dust And Erosion Control

Describe the type of treatment selected, affected areas, and reasons for selection of type and determination of areas.

6.5.8 Fencing

Describe type, height and security measures.

6.5.9 Railroads

- a. Describe general soil conditions, soil exploration and testing performed or to be performed and the results.
- b. Describe the type of service for which railroad track will be provided, anticipated volume and type of traffic, the ruling grade and the maximum curvature.
- c. Indicate the proposed type, source and thickness of ballast, weight of rail and source, treatment and dimensions of ties proposed.

6.5.10 Paving

- a. Indicate the type, speed, volume of traffic and design wheel loads.
- b. Indicate thickness of all pavements and base courses.

Note: For projects estimated to exceed \$100,000 or 20,000 square yards (16723 m² .) in area, include the following additional data:

- c. Design loadings.
- d. Site plan indicating safety clearances.
- e. Evaluation of the reuse of the existing paving materials in the new paving system.
- f. Analysis and justification of the recommended construction.

6.5.11 Airfield Pavement Systems

Describe the following:

- a. The classification and strength characteristics of subgrade soils
- b. Wheel loads and number of operations for each type of aircraft
- c. Evaluation and cost comparison of alternative pavement sections
- d. Vertical and horizontal clearance requirements
- e. Design rainfall frequency and method proposed for storm and hanger deluge system drainage.
- f. Type of lighting to be provided and the adequacy of existing runway and taxiway regulator capacities.

6.6 LANDSCAPE ARCHITECTURE

Describe the following:

6.6.1 Irrigation Systems

- a. The irrigation system (conventional or drip). Include specific areas such as slopes, natural areas, lawn, recreational areas, etc.
- b. Water conservation methods.

- c. Existing irrigation to remain (where applicable).

6.6.2 Plant Materials

- a. Transition areas and the relationship to new construction.
- b. Theme (i.e., entry, color, plant, etc.).
- c. Lawn use and purpose. Give approximate percent of total landscaped area.
- d. Water conservation measures.
- e. Existing plant materials and site furnishings to be removed and/or reused.
- f. General maintenance levels/requirements (such as high, medium, low) for the various types of landscaped areas.

6.6.3 Other Site Features

- a. Signage.
- b. Specialty paving.
- c. Site furnishings.
- d. Landscape lighting.
- e. Project site's environmental context and natural resources.

6.7 ARCHITECTURE

- a. Describe the functional space. Every function listed shall identify its required number of personnel, which will be keyed to their required square footage.
- b. Describe how the space efficiently and effectively meets the operational needs of the customer/activity.
- c. Describe how all the elements of engineering and architecture have been integrated so the interior-exterior elements of the facility are energy efficient, functional, aesthetically pleasing, harmonious and compatible (i.e., materials, colors, textures, lighting, furnishing, equipment, spatial relationship, scale, graphics, signage, landscaping, etc.).

d. Describe how the design complies with MIL-HDBK-1190, "Facility Planning and Design Guide", the Uniform Federal Accessibility Standards, the Americans with Disabilities Act Accessibility Guidelines, whichever provides the greatest accessibility requirements, and in accordance with the Architectural Barriers Act, 42 U.S.C. 4151-4157.

6.7.1 Passive Features

Describe architectural features which contribute to energy conservation. Include day lighting strategies for building design.

6.7.2 Movable Partitions

Provide justification for the use of movable partitions. Indicate how the flexibility of room size has been considered.

6.7.3 Equipment Rooms

- a. Describe in terms of size, access, maintenance, repair and easy removal of equipment.
- b. Indicate how future expansion, if foreseen or planned will be included in the design.
- c. State what criteria was used to determine the size of the equipment room.

6.7.4 Roof Structure

6.7.4.1 Slope

Indicate the roof slope of the design.

6.7.4.2 Drains, Roof

Describe the type of roof drains used. Indicate their location. Describe how the design will provide for differential movement between roof drains and leaders.

6.7.4.3 Parapets

Justify the use of parapets, copings, or similar types of raised peripheral walls.

6.7.5 Colors, Materials and Finishes

State the criteria used to determine the interior and exterior colors, materials and finishes.

6.8 STRUCTURAL

6.8.1 Seismic Design Criteria

Seismic design shall be in accordance with the criteria and design standards of NAVFAC P-355, "Seismic Design for Buildings," dated October 1992, with the following exceptions:

- a. The 1994 edition of the UBC shall be used in lieu of Chapters 3 through 10 of P-355. Tables 3-1 and 3-2 of P-355 take precedence over Figure 16.2 of the 1994 UBC.
- b. Design values obtained from ICBO Evaluation Reports are acceptable.
- c. Design of concentrically braced frames is to comply with Section 2211.9 of the 1994 UBC, "Requirements for Special Concentrically Braced Frames."
- d. Designs using "Special Moment-Resisting Frame (SMRF) Requirements," Section 2211.7 or "Ordinary Moment Frame Requirements" Section 2211.6 of the 1994 UBC, will not be permitted without advance written approval from the Command.
- e. Since much of the ASTM A36 structural steel is produced with yield stress levels in excess of 50 ksi, ASTM A36 steel shall not be used for seismic applications in which system ductility is dependent on limiting yield levels.
- f. The need for dynamic procedures in seismic analysis shall be based on the 1994 UBC requirements. Dynamic analysis of Essential Facilities, Hazardous Critical Facilities and High-risk Facilities, when required, shall be in accordance with the methods prescribed in P-355.1, "Seismic Design Guidelines for Essential Buildings" dated 27 February 1986. All other structures shall be designed using SECTION 1629 --Dynamic Lateral Force Procedures of the 1994 UBC. Any structure may, at the designers discretion, be analyzed dynamically and non-linear time history analysis may be used in lieu of the procedures prescribed above.
- g. The seismic evaluation of existing buildings for potential retrofit shall be in accord with P-355.2, "Seismic Design Guidelines for Upgrading Existing Buildings," dated 1 September 1988. Seismic retrofit design shall consider the recommendations contained in P-355.2. Retrofit designs for unreinforced masonry buildings shall conform to the chapter 1 appendix of the "Uniform Code for Building Conservation."

6.8.2 Foundation Conditions

- a. Describe site conditions, type of foundation to be used, method employed to determine bearing values and maximum dead load and live load soil capacities.

b. Indicate level of ground water.

c. Furnish allowable soil bearing pressures, active, passive and at rest pressures, coefficient of friction and sub-grade modulus and seismic site soil type per UBC.

6.8.3 Type Of Construction

Describe type of construction and framing adopted, and the justification for its use.

6.8.4 Materials

State type of material for each major structural unit and structural system. CAUTION: Structural shapes shall be those readily available on the market and **shall be of U.S. manufacturer.**

6.8.5 Live Loads

a. List snow loads, live loads, wheel loads and any special loads and the source of the criteria.

b. List live loads for all roof and floor areas that differ from the generally assumed live loads.

c. List mooring and deck live loads for waterfront structures.

6.8.6 Lateral Forces

a. Describe the structural system to be employed to resist lateral forces for the structure and associated equipment including mechanical, electrical and architectural.

b. List seismic criteria and wind velocity 80 mph (128 km/h) minimum and indicate which portions of the design are governed by each. Note: Even though wind forces may be used to size structural members, all other seismic provisions must be adhered to in order to permit inelastic response when code seismic design forces are exceeded.

6.8.7 Seismic Design

Describe seismic design criteria for the structure, building equipment (mechanical and electrical) and building non-structural elements and for the utilities systems and components included as part of the project.

6.8.7.1 Floor & Roof Diaphragms

Clearly define the materials that constitute the diaphragms and the method of shear transfer between diaphragms and vertical elements of the lateral force resisting system.

6.8.7.2 Foundations & Slabs On Grade

Indicate how foundations and slabs on grade will be used to distribute lateral forces between the structure and the ground. It must be shown that this transfer mechanism has greater capacity than the yielding elements of the lateral force resisting systems.

6.8.7.3 Pre-Engineered Metal Buildings

- a. All loads and forces necessary to design the pre-engineered metal buildings must be provided by the structural designer of record.
- b. A foundation design must be shown on the contract drawings.
- c. The Structural Designer of record must approve all design calculations and shop drawings.
- d. Retrofits of existing Pre-engineered metal buildings shall, when possible, be completely detailed in the contract documents using standard structural shapes. When the retrofit requires the use of materials available only through a metal building manufacturer, the modification must be clearly defined to permit design by a metal building manufacturer.
- e. The specifications must call for all design drawings, and calculations executed by a metal buildings manufacturer to be sealed by a structural or civil engineer.

6.8.7.4 Reinforced Concrete Masonry Construction

- a. All cells shall be grouted.
- b. Medium weight units shall be specified.
- c. If $f'_m > 1500$ psi, (10,340 kPa) prism tests must be specified to confirm masonry compressive strength prior to and during construction.

6.9 MECHANICAL

6.9.1 Heating, Ventilating And Air Conditioning (HVAC)

DM-3.03, Chapters 8 and 10 of MIL-HDBK 1190, and P-89. Provide a description and schematics of the system and an explanation of why this system is preferred over others. Include in the description the following:

- a. Indoor and outdoor design temperatures.
- b. "U" factors for walls, ceilings, floor, etc.
- c. Special humidification or dehumidification requirements.
- d. Special filtration requirements.
- e. A statement regarding the ability of an existing mechanical system to carry the load when the existing system is expanded or modified.

6.9.1.1 Heating

Include in the description of the heating system the following:

- a. The heating medium, such as steam, hot water, gas or electricity and explain why this medium is preferred over others.
- b. The total flow, pressure and quality requirements of the proposed facility and the ability of the existing utility network to meet these demands.
- c. Indicate location of the heating plant and state if condensate is to be returned.

6.9.1.2 Ventilation

In the description of the ventilation system include the following:

- a. Whether a gravity or mechanical system is to be used.
- b. Whether or not smoke removal systems are proposed.
- c. Indicate the number of outside air changes per hour in various areas, the type of filtration, and applicable OSHA and/or Industrial Hygiene requirements.
- d. Operation of the system in summer and winter modes.

6.9.1.3 Cooling

In the description of the cooling system include the following:

- a. A list of the areas to be cooled.
- b. Locations of major components.
- c. The proposed equipment including the type of refrigerant and water treatment.
- d. Describe the environmental control system type and functions.

6.9.2 Plumbing

DM-3.01. Provide a description and schematics of the proposed systems. Include in the description the following:

- a. The number and type of each fixture based on the number of persons to be served.
- b. The total flow requirement and the estimated maximum and minimum water pressure at each building and a statement if booster pumping is proposed.
- c. The type size, location, and design temperature of the domestic water heater.
- d. The design temperature of the domestic hot water distribution system and a statement if recirculation is proposed.
- e. A discussion of any specialized features such as medical gases, hydraulic systems, or compressed air.

6.9.3 Cold Storage

DM-3.04, MIL-HDBK-1032.02.

- a. Provide a description and schematics of the proposed refrigeration system for the cold storage facility including an explanation of why this system is preferred over others.
- b. List areas to be refrigerated, including their usage and temperatures to be maintained.
- c. Describe the proposed equipment and locate the major components.

6.9.4 Heating Plants

DM-3.06. Provide a description and schematics of the proposed systems. Include in the description the following:

- a. The number, size, type and pressure of the new boilers.
- b. The type of fuel and the proposed storage and distribution systems.
- c. The number and type of new auxiliaries and their power sources.
- d. The type and function of the safety and combustion control systems and how they will perform.

6.9.5 Exterior Distribution Systems

Steam, High Temperature Water, Chilled Water, Natural Gas, And Compressed Air. MIL-HDBK-1003/8A.

Provide a description and schematics of the proposed system(s). Include the description of the following:

- a. Loads and fluid conditions, fluid characteristics, and distribution site locations.
- b. Factor governing test for field permeability, soil resistivity, soil stability and water conditions.
- c. Information on the distribution pipe sizing, valves and supports, distribution methods and piping specifications.

6.9.6 Fuel Distribution And Storage

Provide a description and schematics of the proposed system. Include in the description the following:

- a. Identify type and materials for pipes, tanks, and valves.
- b. For GAS systems describe type, location of take off from supply and available pressure.
- c. For LIQUID systems describe unloading facilities such as dock, tank, car, or truck; state the basis for storage capacity, the rate of pumping and the number of dispensing outlets, the hazard classification and the power requirements.

6.9.7 Elevators, Pneumatic Tube Systems

DM-3.09. Provide a description and schematics of the proposed system including an explanation of why this system is preferred over others.

6.10 ELECTRICAL

6.10.1 Facilities

a. Service: Describe the characteristics, capacity, conductor size, metering, ductbanks and raceways. Describe the total connected load and resulting kilowatt demand load by applying the proper demand and diversity factors. Indicate adequacy of the supply at the point of connection.

b. Transformers: Describe the type to be used, coolant, rating, protective devices, and connections.

c. Main Distribution Switchboard: Describe the rating of the bus, the number of circuit breakers and metering. Include the total computed load.

d. Service Equipment Panel: Describe the phase, voltage, current, power and Asymmetrical Interrupting Capacity (AIC).

e. Lighting and Illumination: Illuminating Engineering Society's (IES) Lighting Handbook except as modified by MIL-HDBK-1190. Indicate lighting level requirements. Describe type of lamps and fixtures to be used and where proposed to be installed. For high bays, discuss accessibility solutions for installation and maintenance. Describe methods for energy conservation. Describe the need for emergency and exit fixtures.

f. Grounding: MIL-HDBK-1004/2. Describe the grounding system required for the facility.

g. Motor Loads: Describe the type of motors, ratings and protective devices.

h. Electronic/Computer Systems: Describe the systems and any special coordination necessary to achieve required overall system performance and any new techniques proposed. Describe demand load of equipment including allowances for expansion and diversity factors used. Describe equipment environmental air conditioning requirements, including cooling load of equipment. Describe special bonding, grounding and shielding requirements.

i. Special Equipment: Describe any special equipment required. Describe the basis of selection, characteristics, and types of enclosures. Include the total connected load and resulting demand.

j. Signaling/Communication: Describe communication requirements in terms of quantity, types of service and power.

1. Describe the types of antennae, transmission lines, method of installa-

tion, termination, switching, etc.

2. Describe radio circuit requirements, including number of circuits and frequencies to be utilized, also wired circuits required indicating those for voice, remote control, etc.

3. Where radio transmission is involved, provide the transmission characteristics to determine need for frequency assignment.

4. Describe special bonding, grounding and shielding requirements.

5. For radar installations, indicate azimuth of coverage and any special precautions to achieve safety to personnel and to minimize interference with other operations.

k. Emergency Power: Describe the need for emergency generators or uninterruptible power systems and method of operation during a power outage. Describe the rating, protective devices and connections.

l. Intrusion Detection Systems (IDS): Describe how the design will meet IDS requirements.

m. Specialized Receptacles: Describe special receptacles used in the design.

n. Wiring Systems: Describe raceways, wire type, conductor insulation, and shielding.

o. Switchgear And Motor Control Centers. Describe the type of circuit breakers and starters to be used, interrupting rating, continuous rating, control power, metering and relaying, and enclosures.

p. Telecommunications/Local Area Network (LAN). Describe the type and arrangement of telecommunication /LAN systems including type and quantity of cables, hardware /accessories and capacity of the existing system. Indicate source and connections to existing systems. Describe current criteria for manholes/handholes, ducts, cables, jacks, backboard, etc., required for proper design of the systems.

q. Lightning Protection System. Describe how the design will meet the requirements for a lightning protection system.

r. Hazardous Locations. Identify all areas considered hazardous with appropriate classification and division based on the National Electrical Code.

6.10.2 Electrical Distribution System

- a. Primary Supply to Station. Describe the electrical characteristics of power supply to the Station, or portion involved including circuit interrupting requirements and voltage regulation.
- b. Station Distribution: Describe the electrical characteristics and adequacy. If inadequate, state measures proposed to correct the deficiency. Describe the basis for selection of distribution voltage.
- c. Standards of Design: Describe the pertinent standards of design, such as voltage drop, physical characteristic of overhead or underground circuits, type of street lighting units and lighting intensities.
- d. Conduits and Conductors: Describe the type of conduit to be used, where installed, depth of installation, and whether direct buried, concrete encased or surface. Describe the type of conductor insulation, shielding, grounding requirements, and where proposed for use.
- e. Loads: Describe the total connected load and resulting kilowatt demand load by applying proper demand and diversity factors, if a group of loads is involved.
- f. Transformers: Describe type of transformer to be used, coolant, rating, protective devices, and connection.

6.10.3 Instrumentation And Control Systems

- a. Describe the overall process to be controlled and the control philosophy. Indicate the control system inputs from the process and the control system outputs to the process. Describe the process sensors and signals, the control system signals and actuating devices. Describe the control algorithms to be implemented. Provide a general sequence of operations. Indicate a typical functional diagram for control of the major process similar to a Scientific Apparatus Makers Association (SAMA) diagram or a function blockwire diagram.
- b. Describe the control equipment signal processing scheme, i.e., electric analog or digital; single processor or distributed processors; programmable logic controller based; personal computer based; single loop controller based; multi-loop controller based; or mini-computer based. Indicate the expected update frequency for critical, typical and non-critical data points in the system. Indicate the expected end-to-end control accuracies.
- c. Describe the hard wired control logic scheme and provide a typical ladder logic diagram to illustrate the method to be used on the contract drawings.

d. Describe the control program programming scheme, ladder diagram logic, function block logic and a typical diagram to illustrate the method to be used on the contract drawings.

6.11 FIRE PROTECTION

Reference all appropriate criteria requirements applicable to the project and explain how these requirements will be incorporated into the design. At a minimum, the following fire protection provisions shall be addressed:

- a. Type of construction and interior finishes.
- b. Classification of occupancy.
- c. Building separations and exposure protection (between project building and surrounding buildings); remedial action required if project involves an existing building.
- d. Height and area limits and allowable increases; fire walls (locations and ratings, including doors, windows, and dampers); remedial action required if project involves an existing building.
- e. Water supplies. Data from hydrant flow tests, comparison of the required versus the available fire flows to determine if the water supply is adequate, and a description of the water supply facilities (e.g., number of pumps available/on line, size of water storage tanks, etc.).
- f. Means of egress requirements. Number and types of exits; Separation of means of egress (fire and smoke partitions and walls and door ratings); exit travel distances; egress capacity and occupant load; exit signage and emergency lighting; etc.
- g. Fire alarm and detection systems. Locations of manual alarm initiation devices and audible/visual warning device requirements; system zoning; type of automatic detection (if required) with areas of coverage.
- h. Extinguishing systems. Identify:
 1. All areas requiring extinguishing systems and the type of system.
 2. Classification of hazard and design density requirements.
 3. Areas requiring gaseous or chemical fire protection systems and design parameters.

4. Size and type of fire pumps and/or standpipes as required.

i. Smoke control systems. Number and locations of smoke zones; method and sequence of operation.

j. Other fire protection features as appropriate to the hazards of the facility.

6.12 CATHODIC PROTECTION

Based upon the soil investigation/corrosive soil and/or water survey/report, describe the requirements for cathodic protection. Provide a list of all metallic underground structures (such as pipes, storage tanks, hydraulic lifts, casing, steel pilings), utilities, and above ground storage tanks. Indicate the type of material of each structure. If cathodic protection is necessary, describe the method of protection.

NOTES

CHAPTER 7. DRAWINGS

7.1 GENERAL

MIL-HDBK-1006/1 Drawing And Specifications as modified by this section provides information and requirements for the preparation of drawings. In case of a conflict, the A-E Guide will govern. Drawings shall include details that are listed in the Naval Facilities Guide Specifications.

7.1.1 Quality Control Check Set Procedures

The A-E's Quality Control individual shall perform all comprehensive checking. This checking shall follow the procedures spelled out in the A-E firms DQCP. This review shall confirm the functional requirements of the program as well as coordinate all drawings and specifications. The following is the minimum acceptable comprehensive check and review method.

- a. Create a complete set of prints and specifications of the project. Mark as "quality control check-set" and date for reference.
- b. The checker shall mark all items checked and found correct in yellow.
- c. The checker shall mark all errors or changes in red.
- d. The drafter shall mark all corrected "red lines" in yellow. This indicates corrections have been made.
- e. The checker shall mark all "yellow over red" corrections in blue. This verifies that corrections have been incorporated onto the originals.

Note: After all "quality control" checking is completed, the check-set with all correction marks, shall become part of the A-E's 100% submittal to the Command. The check-set will be returned to the A-E with the 100% review comments.

7.1.2 Additive Designation

Portions of work which are to be an Additive Bid Item shall be identified on the drawings as "Additive Bid Item". **Do not include the Additive Bid Item number on the drawings.** Rearrangement of priorities at the last minute or by amendment will be simplified if it is not necessary to change the drawings.

7.2 DRAWING REQUIREMENTS

7.2.1 Order Of Drawings

Arrange drawings in the following order:

<u>Type of Drawing</u>	<u>Symbol</u>
Title Sheet	T
Civil	C
Geotechnical	GT
Landscape and Irrigation	L
Architectural	A
Structural	S
Mechanical	M
Plumbing	P
Electrical	E
Fire Protection	FP
Cathodic Protection	CP

7.2.2 Title Sheet

The title sheet shall include the vicinity map, location map, location plan, index to drawings, and a fallout shelter statement, if applicable. The project site, main station entrance, truck delivery entrance and routes, borrow pits, temporary offices as well as contractor site storage yards (all dimensioned to indicate spaces set aside) shall be shown on the location plan. The index shall list drawing reference numbers, drawing titles, and NAVFAC drawing numbers included in the contract in sequential order and by disciplines.

7.2.2.1 Storm Water Discharge Requirements

Projects requiring compliance with NPDES permitting for storm water discharges associated with construction activity (i.e. 5 acres, 2 hectares or more of soil disturbance), the location map shall extend approximately one quarter mile beyond project boundaries showing: the construction site, surface water bodies (including known springs and wetlands), known wells, on outline of off-site drainage areas that discharge into the construction site, general topography, and the anticipated discharge location(s) where the construction site discharges to a municipal storm sewer system or other water body.

7.2.3 Drawing Orientation

Plans shall be oriented with the North arrow pointing upward or to the right and the orientation of all building plans shall be identical and all site plans shall be identical.

7.2.4 Drafting Media

Tracing paper, grid paper, profile paper and vellum will be provided by the government, if available. The Government will not supply Mylar. All sheets will be D size. For drawings on CADD, see Attachment B, the Government will provide disc to the A-E for title block.

Transition to SI drawings will be implemented when supplies are exhausted, at which time International Organization for Standard (IOS) "A" series drawing sheets (A1, etc.) shall be used. All drawings in the contract shall be the same size.

7.2.5 Lettering And Shading

Completed drawings shall be in pencil or ink. Uppercase vertical lettering is preferred and must be plain and legible. The minimum size freehand lettering height on all project drawings shall be 5/32 inch, 3.25 mm. All imaging shall be on the top side. Computer-plotted lettering (pen-plot and 400 dots per inch electrostatic plot) shall be 1/8 inch, 3.25 mm. **The use of pencil or crayon shading or poche' on the back of the drawings will not be permitted because of unsatisfactory reproduction.** All sections or areas normally denoted by poche' shall be indicated by stippling, crosshatching or other pattern indication. Decals placed on the bottom or backside of drawings shall not be used.

7.2.6 Scales

Locate directly under the title of each plan, elevation, section detail, etc., an indication of the scale of the object drawn, (Example: SCALE 1/8" = 1'-0", 1:100). Closely related groups of details having identical scales and tied together with a common title may receive a single indication of scale under their title. Topographic surveys must be drawn at scales of 1" = 10', 1:200, 1" = 20', 1:300 or 1" = 40', 1:400, as appropriate. In addition to the conventional scales, and directly to the left of the title block, shall be a series of graphic scales which shall include every scale used on the sheet. Scales shall be placed in sequence according to size with the smallest uppermost. It is not sufficient to place all scales on one master sheet; each sheet must be treated independently as many drawings are reduced in size and are not always proportionately reduced. Minimum scale for floor plan(s) shall be 1/8" = 1'-0", 1:100. Use an identical scale for all disciplines to facilitate inter-disciplinary plan checking. Roof plan scale shall be identical between disciplines. Minimum scale for landscape construction, irrigation and planting plans shall be 1" = 20'-0", 1:200.

7.2.7 Title And Revision Blocks

Sample drawing title and revision blocks are illustrated by Exhibit 7-A. Note that the construction contract number and specification number are to be placed as indicated (Not the A-E contract number). Title block will be provided by the Government through electronic media or bulletin board.

7.2.8 NAVFAC Drawing Numbers

Assign one NAVFAC drawing number to each sheet. A block of NAVFAC Drawing Numbers will be issued upon request of the A-E when the total number of drawings (sheets) has been established. Once assigned, the NAVFAC number shall not be used on any other sheet.

7.2.9 Sheet Number

In numbering the sheets, apply the basic sheet number and the total number of sheets on the first and last sheets only, (i.e., Sheet 1 of 126). The balance of the sheets shall show only the basic sheet number without the total number, (i.e., Sheet 2 of). The last sheet of the final drawing shall show the last sheet number and the total numbers of sheets, (i.e., 126 of 126).

7.2.10 Drawing Reference Numbers

The A-E shall use "A-1", "M-6", etc. reference numbers for architectural, mechanical, etc., drawings, and shall place them immediately above the standard title block and adjacent to the right border line. See Exhibit 7-A.

7.2.11 Section/Detail Identification

Section identification shall be identified in the following manner.

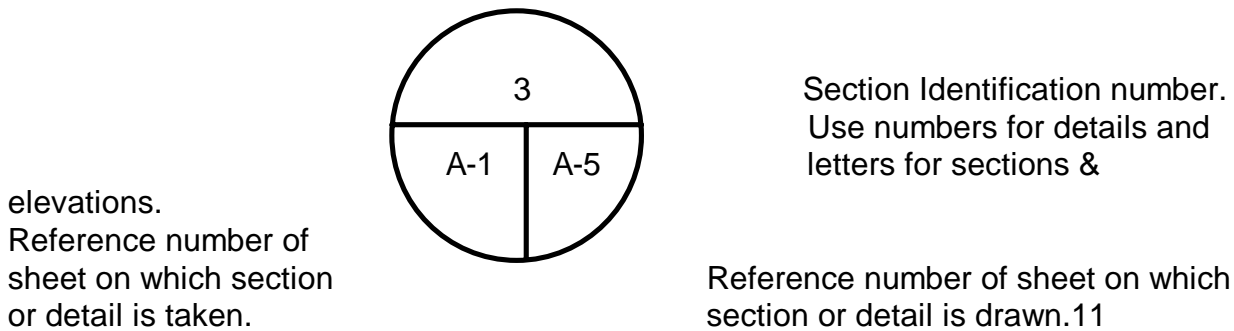

7.2.12 Signatures And Corporate Stamps on Drawings

All designers, draftsmen and checkers responsible for the preparation of drawings shall sign or initial each drawing. Each drawing shall also be signed and stamped by a person of corporate status.

7.2.13 Stamps On Drawings

Each drawing and each set of calculations shall be stamped and signed by the individual who had responsible charge of the design and drawing preparation for each discipline. In states in which any of the above disciplines is not currently registered, the drawing shall be signed and stamped by a registered professional (Architect or Engineer) in the appropriate discipline responsible for preparation of the particular drawings.

7.2.14 Revisions To Contract Drawings

See Chapter 8 for requirements for Amendments and COR Packages. A revision is any change on a drawing after the drawing has been issued to bidders up to the time of completion of construction. Revisions shall be made by erasure, crossing out, addition of new or revised information on the signed drawings or by redrawing.

7.2.14.1 Revision Symbol

A revision symbol will be used to identify the revision. Each change for a revision will indicate the location on the drawing by a triangle with a letter and number (See sample, Exhibit 7-A.). The revision will be identified by an upper case revision letter in sequence; that is Revision A will indicate the first revision to a drawing, Revision B, the second, etc., except that I, O, Q and X shall not be used. All changes made at one time shall be identified with the same revision letter, but shall be followed by a suffix number used serially for each time the letter is used, thus: A2. The revised area on the drawing shall be circled with a soft black pencil in order to make the revision more conspicuous and easily found. The revision symbol shall be located as near as possible to the notes, lines, views, or dimensions which are changed so as to keep the number of symbols to a minimum. Where there are many changes in one area on a drawing so that separate revision symbols would crowd the drawing, a single revision symbol may be used to identify the change if sufficient data is included in the revision block. If the revision accompanies an amendment or Change Order Request (COR), the amendment number or COR letter should be indicated along with a description of the change. **New drawings accompanying amendments or CORs shall bear the following notation in the revision block. "This drawing accompanies amendment number or COR"**. Before revising a drawing, the freehand circles of the drawing for the previous revision shall be removed. Alphabetical revision letters do not necessarily relate to the alphabetical letters of the CORs.

7.2.14.2 Revision Block

Each revision shall be recorded in the revision block of the drawing. The revision letter shall be placed in the "SYM" column. A brief description of the changes shall be made in the description column. See Exhibit 7-A.

7.2.14.3 Approval Of Drawings

Approval of the drawing will be made by the Command in the date and approval column.

7.3 FIFTEEN PERCENT SUBMITTAL REQUIREMENTS

Include the following:

- a. Site plan showing building footprint on contoured base map. Indicate all utility lines, access roads, paved areas, vehicular and pedestrian circulation paths and existing adjacent structures.
- b. List of all rooms and spaces required for the facility. Indicate net square foot/square meter, m² area for each room/space. Indicate total gross square foot/square meter, m² area to the facility as proposed by the design. Include adjustments required by covered areas such as walkways or passageways.
- c. Scaled floor plan drawings. Label all rooms/spaces, show all major dimensions. Include footprint of equipment and furniture required in each space. Indicate mechanical/room/equipment yard and major electrical installations proposed for the facility. Indicate schematic duct work.
- d. Scaled building sections. Show floor to floor, floor to roof and all ceiling heights. Indicate materials and construction for floor, exterior walls and roof. Indicate duct space for HVAC systems if such systems are proposed for the facility.
- e. Scaled building elevations. Indicate material finishes, texture and color number as referenced in the Base Exterior Architecture Plan (BEAP).
- f. A composite drawing will occasionally be required to illustrate the inter-relationships of all design components in the same general space to eliminate conflicts that might occur between building systems.
- g. Structural, Mechanical and Electrical layouts to illustrate the facility design.

7.4 FORTY-FIVE PERCENT SUBMITTAL

Develop all architectural and engineering drawings to a uniform level so that the entire project may be reviewed for conformance with authorized scope and criteria. Combine following drawings as appropriate for simplicity and clarification. For example, show demolition plan and existing topography plan together unless complexities warrant more detail.

7.4.1 Civil Drawings

Include the following:

- a. Existing Topography
- b. Demolition Plan
- c. Site Plan

- d. Grading Plan
- e. Paving Plan
- f. Utility Plan (including Fire Protection)
- g. Retaining Wall Sections

7.4.1.1 Existing Topography

Existing contours shall be plotted at one foot (0.3m) intervals and be clearly distinguishable from new contours. On substantially flat areas where one foot contours are widely separated, augment the topography with spot elevations. All spot elevations on the ground shall be given to the nearest tenth of a foot, and on pavements or structures to the nearest one hundredth of a foot. Scale shall be 1" = 20' (1:200) with scales of 1" = 40' (1:500) for large area projects and 1" = 10' (1:100) for small area projects. The drawing shall be oriented so that the North arrow is up or to the right on the drawing. The following shall be shown:

- a. A topographic survey of the site with at least two points on the traverse set permanently with standard Navy Monuments (Brass Cap in concrete).
- b. Both the horizontal and vertical control monuments including elevations and coordinates.
- c. The bearing and distance between the control monuments.
- d. All surface and subsurface utilities.
- e. All surface structures on and off site that may effect the design.
- f. All trees and shrubs on the project site.
- g. Inverts of all utilities and sizes shall be shown.

7.4.1.2 Demolition Plan

Indicate the following:

- a. Type and thickness of structures, foundations and pavements to be removed.
- b. Sizes and materials of all existing utility lines to be removed.
- c. Limits of demolition.

- d. Size and thickness of trees to be removed.
- e. Trees and shrubs to remain.

7.4.1.3 Site Plan

- a. Locate all new work by coordinates or dimensions from prominent existing structures.
- b. Clearly distinguish new facilities from existing.
- c. Indicate the following:
 - 1. Building Location
 - 2. Access Roads
 - 3. Parking
 - 4. Survey Control Points
 - 5. Bench Marks
 - 6. Sidewalks
 - 7. Finished floor elevations

7.4.1.4 Grading Plan

Shall be of the same orientation and scale as the existing topography plan. Existing contours shall be clearly distinguishable from new contours. Indicate the following:

- a. High and low points and grade breaks with spot elevations. Additional spot elevations shall be provided along ditches at culverts, inverts and at all other critical surface positions to indicate surface run-off. Spot elevations on the ground shall be shown to the nearest tenth of a foot (31mm) and those on structures or pavements to the nearest one-hundredth of a foot (3mm).
- b. Finish floor elevations for all buildings and concrete slabs.
- c. Top elevations and inverts of all drainage structures and ditches.
- d. Limits of grading.
- e. Vertical control benchmark.
- f. Buildings, structures and pavement areas.
- g. Pavement types.
- h. Erosion and Sediment Control Measures.

7.4.1.5 Paving Plan

- a. Orient and scale as the site plan.
- b. Indicate the following:
 1. Airfield pavements, roads, curbs, gutters and shoulders in section views.
 2. Type and thickness of structure including base course and sub-base.
 3. Wheel loadings for airfield pavements, grating and covers.
 4. Joint pattern and details for rigid pavement layout.
 5. Pavement markings and striping.

7.4.1.6 Utility Plan

- a. Orient and scale the Utility Plan the same as the Site Plan.
- b. Indicate the following:
 1. Location, alignment, type of utility, and pipe size of all new and existing utilities. These utilities will normally include domestic water, fire protection, water, sanitary sewers, storm sewers, natural gas, electrical, steam, high-temperature hot water, compressed air and P.O.L. product lines.
 2. Horizontal alignment at a dimensional offset from and parallel to the edge of a building or structure, the centerline or edge of a road or street, a fence line or other physical feature.
 3. Vertical alignment or grade by a defined nominal distance below finish grade for water lines, gas lines, electrical ductbank and P.O.L. product lines.
 4. Vertical alignment for sanitary and storm sewer lines by invert and top elevations at all manholes, catch basins and curb inlets.
 5. Point of Connection (P.O.C.) of the new utilities, including Fire Protection.

7.4.2 Geotechnical Drawings

Include the following:

- a. Soil Boring Logs and Data.
- b. Soil Boring Location.

7.4.2.1 Soil Boring Logs And Data

The site soil conditions shall be indicated as boring logs on the drawings. Locations of borings shall be shown on the Civil Site Plan. A small scale location plan shall accompany the boring logs. Soil boring logs shall be drawn in accordance with Exhibits 3-A, 3-B, 3-C and as contained in DM-7 and DM-21. The GT sheets shall also include tabulated results of chemical and/or physical properties test as appropriate to adequately describe the site conditions expected to impact facility construction.

7.4.3 Landscape Architecture Drawings

Include the following:

7.4.3.1 Landscape Construction Plan

- a. Site signage, fencing and playground area.
- b. Landscape drainage layout (i.e., piping and catch basins/drain inlets).
- c. Site legend with symbols and descriptions.

7.4.3.2 Irrigation Plan

- a. Irrigation head layout, both existing and proposed.
- b. Piping layout (lateral line only).
- c. Irrigation legend with symbols and descriptions.

7.4.3.3 Planting Plan

- a. Tree, shrub, vine, groundcover and lawn locations.
- b. Site furnishings (i.e., benches, tables, tree grates, bicycle racks, trash receptacles, playground equipment, etc.).
- c. Existing plant material(s) and/or site furnishing(s) to remain. Use dashed outline symbol to represent these elements.

d. Plant legend with botanical and common names, sizes, quantities and additional remarks.

e. Site furnishings legend with symbol and description.

7.4.4 Architectural Drawings

Include the following:

a. Architectural Site Plan.

b. Demolition Plan.

c. Floor Plans.

d. Roof Plans.

e. Exterior Elevations.

f. Building Sections.

g. Wall Sections.

h. Room Finish Schedule.

i. Large Scale Plans.

j. Interior Elevations.

k. Equipment Layouts.

7.4.4.1 Architectural Site Plan

Indicate new and existing buildings, structures, roads, parking, sidewalks, and site improvements. Identify all structures and site features. Provide campus plan(s) for multiple building developments.

7.4.4.2 Demolition Plans

For renovation work and additions to existing facilities, indicate existing construction, items to be removed or altered, and new work.

7.4.4.3 Floor Plans

Indicate all required spaces. Provide space identification, number, and function. Indicate all windows, doors, walls, partitions, moveable partitions, built-in equipment, and significant features of the facility. Indicate collateral equipment which affect the plan layout (as trainers, machinery) or are necessary for accurate placement of utilities (as laboratory tables, BEQ furniture). Indicate overall and critical dimensions.

7.4.4.4 Roof Plans

Indicate type of roof, direction of slopes, roofing type, access to roof, and mechanical and electrical equipment.

7.4.4.5 Exterior Elevations

Show all exterior elevations. Indicate height of floors, and major vertical dimensions. Indicate type and extent of finish materials.

7.4.4.6 Building Sections

Show sections through entire facility indicating floor and ceiling heights, major structural elements, and major equipment (as flight trainer).

7.4.4.7 Wall Sections

Indicate wall sections including foundation and roof which illustrate and identify the construction elements and location. Indicate significant dimensions.

7.4.4.8 Room Finish Schedule

Indicate finishes of floors, bases, walls, partitions and ceilings for all spaces.

7.4.4.9 Large Scale Plans

Show enlarged plans of complex spaces (as kitchens, laboratories) and typical spaces (as BEQ, BOQ modules).

7.4.4.10 Interior Elevations

Show elevations of interior spaces. Indicate finishes, trim, shelving, and equipment. Indicate heights of cabinets, work surfaces, wainscots, and ceilings.

7.4.4.11 Equipment Layouts

Indicate and identify major furniture and equipment. Indicate items which are existing and relocated, new collateral equipment, or equipment provided by the Contractor.

7.4.5 Structural Drawings

Include the following:

- a. General Notes and Typical Details.
- b. Foundation Plan.
- c. Floor Framing Plan.
- d. Roof Framing Plan.
- e. Sections and Details.
- f. Elevations.
- g. Schedules.

7.4.5.1 General Notes And Typical Details

Include all loads: snow, roof and floor loads, wheel loads, seismic criteria, and wind loads. List any special loads such as crane loads and for other concentrated loads and, if necessary for clarity, provide a diagram. State dead, live and total allowable loads on the soils and corresponding loads actually used. List mooring and deck loads for waterfront structures. Include the application/location and units of measure for each load. Design data shall be separated from the General Notes. Material notes shall identify all materials used such as structural steel, concrete, masonry, etc.

7.4.5.2 Foundation Plan

Use the same scale and orientation as the architectural plans. Show the sizes, location and arrangement of all significant features of the foundation system. Include the layout of all slabs, footings, piers, grade beams, piles, caissons, pile/caisson caps, trenches, pits, openings, depressed and thickened slabs, etc. Provide a column-line grid system oriented about the axes, usually length and width, of the structure and along the center-lines of the major support columns and walls. Elevations may be given using any datum consistent throughout the structural drawings so long as the chosen datum is referenced to the true elevation. Show adjacent existing structures and foundations which will impact the new construction.

7.4.5.3 Floor And Roof Framing Plans

Orientation of framing plans shall match the foundation plan. Show the sizes, location and arrangement of all significant features of the horizontal framing system. Include the layout of all beams, joists, stringers, purlins, slabs, decks, plates, grating, etc. showing all

dimensions and elevations necessary to fully describe the basic structural system. The elevations shall be referenced to some finished datum such as top of steel, slab, finished floor, concrete, joist, deck, etc. Special construction features and site conditions which have a significant impact on project cost shall be shown.

7.4.5.4 Elevations

Line drawings representing the lateral load resisting systems shall be indicated.

7.4.5.5 Sections And Details

Provide sufficient information to identify the types of material and methods of construction required such that a reliable cost estimate can be developed for the structure. All parts or pieces shall be identified and shown in sufficient detail to provide relationships to other structural/architectural features.

7.4.6 Mechanical Drawings

Provide a general layout of the systems proposed, including total loads and single-line drawings and schematic diagrams, showing general arrangement of mechanical equipment, piping, and ductwork. Include the following drawings (Additional description of these drawings is in paragraph-MECHANICAL 100% SUBMITTAL):

- a. Plot or Site Plans (for projects with extensive external systems).
- b. Mechanical Plans.
- c. Schematic Diagrams.
- d. Equipment Schedules.
- e. Fire Protection system(s)

7.4.7 Plumbing Drawings

Provide a general layout of the systems proposed, showing the general arrangement of the fixtures, equipment, and piping. Include the following drawings (Additional description of these drawings is in paragraph PLUMBING 100% SUBMITTAL):

- a. Plot or Site Plans (for projects with extensive external systems)
- b. Plumbing Plans
- c. Isometric & Schematic Diagrams

- d. Fixture & Equipment Schedules
- e. Fire Protection System(s)

7.4.8 Electrical Drawings

Include the following:

- a. Notes, Legends, Symbol List.
- b. Existing Site and Demolition Plan.
- c. Site Plan.
- d. Single Line Diagrams.
- e. Floor Plan(s).

7.4.8.1 Notes, Legends And Symbols List

Electrical symbols shall conform to ANSI Y-32.3 and Y-32.9.

7.4.8.2 Demolition Plan

Include existing electrical site information such as buildings, pavements and utilities. Electrical demolition shall be shown on this drawing and indicated by legend. Demolished features should not be shown on subsequent drawings. Interior demolition shall be shown on a separate plan.

7.4.8.3 Site Plan

Show new and remaining aboveground and underground electrical equipment. When located in proximity to other utilities, all should be shown to avoid conflicts. Information on existing conditions shall be complete. Show circuits and feeders. Show conductor by size, number, voltage and type of insulation.

7.4.8.4 Single Line Diagrams

This plan shall show (including electrical characteristics and ratings) the following:

- a. Existing distribution to a point of connection.
- b. Primary feeder to project.
- c. Pad-mounted transformer or substation with primary and secondary switchgear.

d. Secondary Feeders.

e. All panels, switchboards, motor control centers, transformers and other major electrical loads such as M.G. sets, A/C chillers, etc.

7.4.8.5 Floor Plans

a. Lighting Plan(s). Show a building's full floor plan (first, second, etc.). These plans shall show the layout and type of fixtures to be used for all types of lighting systems.

b. Power Plan(s). Show a building's full floor plan (first, second, etc.). The power plans shall show the location of receptacles, panelboard(s), switchboards, motor control centers, transformers and any other major equipment throughout the inside of the building or project.

c. Communication/Signal Plan(s). Show building's full floor plan (first, second, etc.) with the location of devices and hardware/accessories. These plans shall show the following:

- (1) Telephone
- (2) Intercom
- (3) Local Area Networks (LAN)
- (4) Closed Circuit Television (CCTV)
- (5) Others as required
- (6) Fire Protection System(s)

7.4.9 Fire Protection System(s)

Show existing and proposed fire alarm boxes and circuits. Show sizes of existing and proposed water mains, risers and fire hydrant locations. Show separation distance from adjacent buildings.

7.5 PROJECT DRAWINGS - 100 PERCENT SUBMITTAL

Project drawings shall be complete and camera ready for reproduction and advertisement with all elements thoroughly checked by the A-E. After all Quality Control checking is completed, the check-set with all correction marks, shall become part of the A-E's 100% submittal to the Command. Drawings and specifications shall contain the same terminology. **SOUTHWESTNAVFACENGCOM reserves the right to advertise and award the construction documents at the 100 percent submittal stage.**

7.5.1 Civil Drawings

Include the following:

- a. Existing Topography
- b. Demolition Plan
- c. Utility Site Plan (Including Fire Protection System(s))
- d. Plot Plan
- e. Grading Plan
- f. Paving Plan
- g. Plan and Profile
- h. Profiles
- i. Cross sections
- j. Dredging Drawings
- k. Details and Sections, Civil
- l. Painting and Striping
- m. Utility Systems Seismic Design
- n. Soils Boring Logs and Data

7.5.1.1 Existing Topography

Existing topography shall be the record of a field topographic survey performed by a licensed Land Surveyor on a proposed project site. The specific project limits shall be indicated. On sanitary and storm sewer lines, manholes, catch basins and clean-outs shall be identified and located. The utility line inverts shall be indicated.

7.5.1.2 Demolition Plan

- a. Indicate all existing structures, foundations, and pavements, including type, dimensions, and thickness, which will require demolition and removal prior to the new project construction. It is essential that the limits of removal be clearly identified and dimensioned, and a depth requirement established for all foundation removal.

Photographic reproductions of complicated buildings for structures to be demolished may be used to supplement drawings and notes for clarity.

- b. Show buried tanks and structures like inlets and manholes that are not to be completely removed, but abandoned in place filled with sand.
- c. Indicate **all existing utility lines (including Mechanical and Electrical)** to be removed or abandoned in place.
- d. Indicate all existing trees and shrubs to be removed or saved.
- e. Deposition of the demolished and removal material shall be clearly indicated. Material to be salvaged shall be identified and direction given by notes as to how and where it shall be stored or deposited. Asbestos and other hazardous materials at the site shall be identified and a safe removal-disposal plan developed.

7.5.1.3 Utility Plan

Sanitary and storm sewer lines shall have invert and top elevations indicated at all manholes, catch basins and curb inlets. All significant appurtenances shall be identified including Fire Protection System, by symbol and/or noted. Indicate new fittings to make proper connections. Indicate related features.

7.5.1.4 Site Plan

The site plan shall be drawn to the same scale and orientation as the existing topography plan. Locate and dimension all new structures, buildings, walks, parking areas, roads, etc., by coordinates, dimension offsets from a horizontal control base line or stationing, and offsets from a road centerline. Road and railroad alignment shall indicate stationing, centerline tangent bearings, and curve data. Major new utility supply lines routing shall be indicated by tangent distances and bearings along the centerline of the pipe. Project limit lines shall be clearly delineated showing contractor's area of responsibility; the contractor's office area, storage and lay-down areas. Where new project work interfaces with existing facilities within the site, the new work shall be clearly delineated by heavy outline, symbols, and/or notes.

7.5.1.5 Grading Plan

The grading plan shall show earthwork, indicate daylight line between cut and fill embankments, excavations, select borrow fills, ditches and swales, and surface elevations of pavement areas, curbs, culverts, catch basins, and manholes to present an adequate surface drainage plan and storm drainage system for the entire project site. Erosion and sediment control measures shall be indicated. Identify all buildings, structures, pavement areas and note pavement types. The plan shall be of the same orientation and scale as the existing topography plan. The surface runoff pattern shall be indicated by finish grade

contours, using heavy solid lines at one foot intervals with storm drainage flow arrows along earth swales and irregular pavement surfaces. Provide complete retaining wall details including graded filter material and provisions for drainage. Provide the finish elevations at all corners and grade breaks for all buildings and concrete slabs and indicate the top elevation and inverts of all drainage structures. Additional spot elevations shall be provided along ditches at culvert inverts and at all other critical surface positions to clearly indicate surface runoff. Indicate the limits of grading. Indicate the location of the disposal or borrow area and hauling routes. Location of test pits may be shown on this plan. Spot elevations on the ground shall be shown to the nearest tenth of a foot and those on structures or pavements to the nearest one-hundredth of a foot. The vertical control benchmark, shown on the existing topography plan, shall be repeated on this plan.

7.5.1.6 Paving Plan

Orient and scale the paving plan the same as the plot/site plan. The pavement plans shall show the location, limits, and alignment of all airfield pavements, parking areas, storage areas, roads, curbs, and gutters, walks, and patios. Pavement surface, base course, sub-base course materials and thickness shall be indicated by note and legend symbol. Earth shoulder and subgrade preparation and compaction requirements shall be indicated by note. Rigid pavement layout shall indicate the joint pattern, identifying the type of joint by line or note symbol. Design surface elevations shall be indicated around the perimeter, and along all construction joints at slab corners at 75' to 100' intervals, or more often, as may be required, to reflect changes in grade. Transition pavements and fillets on airfield pavements or road intersections will require additional surface elevations to establish the transition grades or warped surfaces. Steel reinforcement or temperature steel location, sizes and spacing shall be indicated by note, symbol or enlarged detail on the same drawing or on a detail drawing. All embedded structures or items such as manholes, pits, tie-downs, ground receptacles, etc., shall be indicated and their effect on the standard joint pattern shall be shown. Design wheel loading for airfield and roadway pavements, grating and covers shall be noted. Design surface elevations for flexible pavements shall be indicated around the perimeter, at curb inlets and catch basins, and at locations within the paved area to reflect changes in grade. Crowned road pavements shall have surface elevations indicated along the roadway centerline and along both edges. Super-elevation diagrams shall be shown for the curved road. Sidewalk and patio pavements shall indicate the joint pattern, set at grade of control curb or building line or conform to adjacent topography, and shall indicate a design transverse slope to assure free-draining surface. Typical cross-sections of all pavement design sections on the project shall be shown on the paving plan or shown on a detail drawing and cross-referenced. Special pavement details including joint details, steel reinforcement, tie-downs, grounding receptacles, curb or curb and gutter sections, new pavement abutting existing pavement, etc., may be shown on the paving plan or shown on a detail drawing and cross-referenced.

7.5.1.7 Plan And Profile

Where the new facility or utility involves a long linear strip of topographic area, special preprinted "Plan-Profile" sheets may be used. The plan view shall be stationed from left to right, complete with a given starting station and ending station, widths, and all topographic features indicated. The grade profiles shall be indicated on the grid section of the sheet, stationed similarly from left to right, and shall cover the same length of facility/utility as the plan section. Where several sheets are required, a "match line" shall be shown on both adjacent sheets and clearly identified for continuity.

7.5.1.8 Profiles

Profiles shall be clearly identified and cross-referenced to the road or utility on the plot plan. The scale for profiles shall generally have a ratio of 10:1 horizontal to vertical. The horizontal scale shall be the same as the site plan. On the profiles drawing:

- a. Show profiles for all sanitary and storm sewers. For storm sewers serving tributary areas of ten (10) acres (4 hectare) or more or any pipe 12" (30mm) in diameter (30mm) or greater under pressure flow, show hydraulic grade lines.
- b. Indicate the existing and finish grade, all manholes and catch basins, invert elevations, stationing of all appurtenances, the slope of the pipe between appurtenances, clearly indicating the invert (flow line) and top of the new utility pipe.
- c. Show profile for water mains or transmission lines indicating valve boxes and other appurtenances located by stationing.
- d. Show profiles for centerlines, edges, and ditch lines of roads, runways, and taxiways, complete with stationing and vertical curve information for changes in grade.

7.5.1.9 Cross Sections

- a. Show for all new roads, runways, taxiways, and pier aprons; and for all reconstructed roads, runways, and taxiways where the reconstructed grade varies substantially from the existing grade.
- b. Surface and base course scarification, regrading and recompacting to restore original grade and section, will not require cross sections.
- c. Show the cross-section of all intersecting existing and/or new utility lines or culverts to indicate possible interferences of one utility to another, or indicate amount of cover-over pipes or culverts.
- d. Cross sections shall be:

1. Provided for all site areas where substantial excavation, embankment, or engineered fill is intended; or where airfield approach-departure clearances are shown.
 2. Taken normally at every Station in 100 foot intervals (30m) with additional sections taken in between at grade breaks or other topographic irregularities which would cause inaccuracies in earthwork quantity computations.
 3. Plotted starting with Sta. 0+00 at the lower left hand corner of the drawing, and proceed up and to the right with increasing stationing.
 4. Plotted normally at a vertical scale of 1" = 2' and horizontal scale of 1" = 10' (1:100) or 1" = 20' (1:200), and the centerline and edges finish grade elevation indicated at each Station.
 5. Taken at 50' (15m) or closer for pavement widening and repair projects where a smooth join with existing finished surfaces is required.
- e. Special sections traversing the entire facility site, at typical locations or at right angles to each other, are sometimes required to clearly indicate the required work where the building foundations are set on or within engineered fill, or unusual grading problems are encountered.

7.5.1.10 Dredging Drawings

The limit of dredging shall be depicted by the contract dredging depth contour and any limiting waterfront structure. Dredging drawings will normally consist of the hydrographic survey plans; and the dredging sections and details.

- a. The hydrographic survey plan will show:
 1. Waterfront area.
 2. Limits of dredging.
 3. Contract dredging depth and overdredge allowance.
 4. Channel widths.
 5. Existing piers, wharves, docks, quaywalls, groins, breakwaters, and any other waterfront structure which might limit or control the dredging operations.
 6. Soundings depicting the elevations below MLLW of the channel or harbor at every Station (100' interval) (30m) or half-Station (50' interval) (15m) along a pier line or base line, and at a 25' interval (7.5m) in a transverse direction.

Where soundings are obtained with an automatic continuous recording fathometer, the 25' interval (7.5m) is not applicable. Additional soundings shall be taken in critical areas, and in areas of irregular bottom conditions, high or low spots, or any artificial sunken obstruction.

7. Horizontal control points and vertical control benchmarks shall be indicated.

8. Soil test borings locations.

9. Disposal site.

10. Dredging phasing sequence.

11. All referenced horizontal and vertical control points and datum.

b. The dredging sections and details drawing shall show:

1. Cross-sections or typical sections as the project might require.

2. MLLW line.

3. Existing seabed (mudline).

4. Contract dredging depth.

5. Overdredge allowance depth.

6. Pay depth.

7. Design side slope against piers or along the perimeter of the dredging area.

8. Any special sloping.

9. Rip-rapping and/or pier modification related to the dredging.

10. Subsurface buried cable or other utility line requiring special care in the dredging operation.

7.5.1.11 Details And Sections, Civil

Show at an adequate scale and sufficiently annotated to clearly define the work intended. Whether the details and sections are indicated to be to scale, or labeled not to scale (N.T.S.), they shall be drawn proportionally so as not to give a distorted view of what is

intended. All details and sections shall be clearly identified and cross-referenced to the plan showing their location.

- a. Details would include but not limited to manholes, catch basins, inlets, pipe bents and connections, fire hydrants, valve boxes, underground tank installation, pavement reinforcement and joint details, curbing details, fencing details, and all special installation features.
- b. Sections would include but not limited to all typical roadway sections, pavement sections, ditch sections, dike sections, trenching sections, etc.

7.5.1.12 Painting And Striping

Pavement (road and airfield) and parking area painting and striping locations, pattern and detail can be shown on the site plan or paving plan for many small to average sized projects. However, when the facilities requiring painting and striping are of such magnitude that they would clutter up another drawing, they may be presented on a separate drawing. All markings, raised markers, figures, and stripes shall be clearly located by dimensions, and the width of stripes and spacing of dashed lines clearly indicated. Special arrows, crosswalks, lettering on the pavement surface, and special symbols shall be detailed and fully dimensioned. The type and color of the markings should be identified, such as reflectorized or non-reflectorized traffic paint, yellow, red or white.

7.5.2 Landscape Architecture

Include the following:

7.5.2.1 Landscape Architecture Plan

- a. Landscape dimensioning and layout. Indicate point of beginning.
- b. Detail referencing.
- c. Fencing, signage and playground layout.
- d. Landscape drainage layout (i.e., piping and sizing, direction of flow, slope of pipe, all catch basins/drain inlets and all invert and rim elevations). Indicate connections to existing storm drain systems or outfall areas.
- e. Site legend including symbols, descriptions, finishes, material types, color and quantity.

7.5.2.2 Irrigation Plan

- a. Irrigation plan shall be on a separate sheet, but at the same scale as the planting and landscape construction plans. Minimum scale size shall be 1"=20'-0", 1:2000.
- b. Piping (main, lateral and sleeving) layout and sizing. Show distinct symbols for potable and non-potable pressure and non-pressure existing and new irrigation lines, and supply lines. Include these symbols in the irrigation legend.
- c. Irrigation head/emitter module layout, both existing and proposed.
- d. Valve (standard control, drip assembly, isolation, gate, ball and quick coupler) layout, sizing and sequencing. For each standard control and drip assembly valve include total flow (GPM or GPH). For drip assembly valves, indicate pressure regulator setting.
- e. Point of connection location, size, type of line and static PSI availability.
- f. Size and location of reduced pressure backflow preventer/water meter/pressure regulator/wye strainer assembly.
- g. Location, size and type of controller and location of power source for controller.
- h. Location and size of water pump.
- i. Location of in line swing and/or spring check valves.
- j. Location of automatic drain valves for drip irrigation systems only.
- k. Location of soil moisture sensors and/or rain shut off device(s).
- l. Location of separate drinking fountain potable water line. Coordinate connection to sewer line (if applicable).
- m. Irrigation legend indicating symbols, psi, gpm/gph, radius, pattern, nozzle size, descriptions and detail reference.
- n. Irrigation installation notes.

7.5.2.3 Planting Plan

- a. Locations of trees, shrubs, vines, groundcovers and lawn area.
- b. Location of lawn and playground edging material.

- c. Exact location of aboveground utilities (i.e., fire hydrants, electrical transformer, TV cable box(es), telephone and electrical poles, overhead wires, sewer and water manholes, steam lines, street lights, gas handholes, etc.).
- d. Existing plant materials/site furnishings to remain. Use dashed outline symbols to represent these elements.
- e. Plant legend with common and botanical name, symbol, size, quantities, detail reference, additional remarks, turf and/or wildflower seed mix, germination rate and slurry composition, erosion control blanket type and drip emitter quantities/GPH output for each plant type.
- f. Separate site furnishings legend with symbol, finishes, textures, material type, color, quantity and description.
- g. Planting installation notes.
- h. Coordinate site features (i.e., new or existing walkways, building pads, utilities and roadways) with other disciplines for accuracy of layout.

7.5.2.4 Irrigation Details

- a. Show adequate irrigation details to enable the contractor to properly assemble, install and attach all irrigation equipment and piping that are indicated on the plan(s). Key the details to the other drawing(s) using the bubble system described in section 7 under "detail identification".

7.5.2.5 Planting, Site Furniture, And Drainage Details

- a. Show adequate planting, drainage and site furniture details to enable the contractor to properly fabricate, assemble, install and attach drainage equipment and piping, site furniture and plant materials that are shown on the plan(s). Key the details to the other drawing(s) using the bubble system described in section 7 under "detail identification."

7.5.3 ARCHITECTURAL DRAWINGS

Include the following:

- a. Architectural Site Plan.
- b. Demolition Plan (when required).
- c. Floor Plans (1/8" scale, 1:100 minimum).

- d. Reflected Ceiling Plans (same scale as floor plans).
- e. Roof Plans (same scale as floor plans).
- f. Exterior Elevations.
- g. Building Sections.
- h. Wall Sections.
- i. Room Finish Schedule (with color schedule).
- j. Door and Window Schedule.
- k. Large Scale Plans ($\frac{1}{4}$ ", 1:50 scale minimum for toilet rooms, laboratories, control rooms, and other special activity areas).
- l. Interior Elevations ($\frac{1}{4}$ ", 1:50 scale minimum).
- m. Door and Window Details (3", 1:5 scale minimum).
- n. Miscellaneous Details.
- o. Equip. Layouts & Schedules (for medical, kitchen, shop equip., etc.).

7.5.3.1 Architectural Site Plan

Indicate new and existing buildings, structures, roads, parking, sidewalks, and site improvements. Identify all structures and site features. Provide campus plans for multi-building developments.

7.5.3.2 Demolition Plans

For renovation work and additions to existing facilities, indicate existing construction, items to be removed or altered, and new work.

7.5.3.3 Floor Plans

Indicate all required spaces. Provide space identification, function/capacity and room number. Indicate all doors, windows, moveable partitions and their identifying symbols. Indicate wall, partitions, structure, built-in equipment/collateral equipment. Identify sections and locations of enlarged plans. Indicate required dimensions and gross area of floor.

7.5.3.4 Reflected Ceiling Plans

Indicate type and extent of ceiling materials. Indicate electrical fixtures, HVAC diffusers, openings, equipment, special features.

7.5.3.5 Roof Plans

Indicate type of roof, direction of slopes, parapets, expansion and isolation joints, roof drains, scuppers, sky lights, mechanical and electrical equipment, and curbs for any roofing membrane penetration. Indicate sections cut and required dimensions.

7.5.3.6 Exterior Elevations

Show all exterior elevations. Indicate height of floors, and vertical dimensions. Indicate type and extent of finish materials. Indicate swing/direction of movement for windows and doors.

7.5.3.7 Building Sections

Show sections through entire facility. Indicate floor and ceiling heights, structural elements, exposed wall surfaces and major equipment.

7.5.3.8 Wall Sections

Indicate wall sections including foundation and roof construction where applicable. Illustrate and identify materials and locations. Indicate all required dimensions.

7.5.3.9 Room Finish Schedule

Indicate finishes of floors, bases, walls/partitions, cabinets, trim, ceilings, ceiling heights, and special requirements for all interior spaces. Include color schedule for all finish materials.

7.5.3.10 Door And Window Schedules

Indicate all doors, windows, and folding partitions. Indicate door and frame type, size, thickness, fire-rating, louvers, hardware, glazing and special requirements. Include elevations of doors, frames, windows and partitions.

7.5.3.11 Large Scale Plans

Show enlarged plans of complex spaces (such as kitchens, laboratories, control rooms). Indicate built-in/collateral equipment, special requirements. Provide required dimensions.

7.5.3.12 Interior Elevations

Provide elevations of interior spaces. Indicate finishes, trim, cabinets, shelving, built-in/collateral equipment. Indicate heights of cabinets, work surfaces, wainscots, trim, and ceilings. Indicate mounting heights of all equipment accessories.

7.5.3.13 Door And Window Details

Show head, jamb, and sill details of all windows and doors. Indicate frames, anchorage, glazing, sealants, all special requirements.

7.5.3.14 Miscellaneous Details

Show details of all cabinets, partitions, accessories, built-in equipment and special requirements.

7.5.3.15 Equipment Layouts

Provide plans of all collateral and contract equipment. Provide schedule indicating responsibility for purchase, removal, shipping, receiving, installing and testing of all equipment.

7.5.3.16 Ceiling Systems

Support and seismic restraint of ceilings systems shall be detailed. Details must include diagonal splay restraints and compression struts.

7.5.4 Structural Drawings

Include the following:

- a. General Notes and Typical Details.
- b. Foundation Plan.
- c. Floor Framing Plan.
- d. Roof Framing Plan.
- e. Elevations.
- f. Sections and Details.
- g. Schedules.
- h. Other Drawings.

7.5.4.1 General Notes And Typical Details

- a. Design criteria, design loads, allowable stresses, material properties and reference standards.
- b. Material notes such as structural steel, concrete, masonry, etc.
- c. Bid information such as pile/caisson lengths, excavation depths, footing elevations, etc.
- d. Special test requirements.
- e. Abbreviations and symbols.
- f. Construction details that are applicable to significant portions of the design, and that can readily be identified by a referenced section cut(s).

7.5.4.2 Foundation Plan

- a. Layout of foundation support systems showing all dimensions and elevations necessary for construction. The foundation plan must be fully dimensioned without reliance on dimensions located on other drawings.
- b. Size or schedule references for all foundation features such as footings, grade beams, piles, caissons, pile/caisson caps, etc.
- c. Control/expansion/construction isolation joints in slabs, walls and grade beams.
- d. Trenches, pits, openings, depressed/thickened slabs.
- e. Test pile/caisson locations.
- f. Existing and final site conditions/features.
- g. Indicate bearing walls, columns, dowels, straps, holdowns, etc.

7.5.4.3 Floor And Roof Framing Plans

- a. Layout of horizontal framing elements showing all dimensions, orientation, grid lines and elevations necessary for construction.
- b. Size or schedule references for all horizontal framing elements such as beams, joists, purlins, slabs, headers, decks, grating, etc.
- c. Control, expansion, and construction joints.

- d. Openings requiring special framing or reinforcing.
- e. Location of splices, brackets, penetrations, sleeves, embedments, bracing, weldments, etc.
- f. Other special requirements, such as equipment clearances, travel distances for hoists and cranes, etc.
- g. Catwalks, ceiling framing lower chord bracing and other intermediate level framing shall generally be shown on separate framing plans.
- h. Show diaphragm reinforcing, diaphragm chords and diaphragm truss layouts.
- i. Indicate locations of special connection and special reinforcing.
- j. Indicate locations of vertical lateral load resisting elements.
- k. Identify collector (drag) members and detail special connections to transfer drag loads between elements.

7.5.4.4 Elevations

- a. Layout of vertical framing elements showing all dimensions, orientations and elevations necessary for construction.
- b. Size or schedule references for all vertical framing elements such as columns, walls, piers, beams, bracing, etc.
- c. Wall panel layouts including control/expansion/construction joints.
- d. Openings requiring special framing or reinforcing.
- e. Location of splices, brackets, penetrations, sleeves, embedments, bracing, weldments, girts, lintels, headers etc.
- f. Other special requirements such as equipment clearances, travel distances for hoists and cranes, etc.

7.5.4.5 Sections And Details

- a. Sections and details showing all parts, shapes, sizes, materials, dimensions, elevations, arrangement and orientation necessary for construction.
- b. Schedule references for fasteners, welds, plates, clips, ties, stirrups, pins, etc.

- c. All connections completely detailed to a point where no further engineering is necessary.
- d. Concrete/masonry wall reinforcement details showing size, clearances, placement, shape, etc. Also show shear wall boundary element and boundary zone detailing.
- e. Anchor bolts, base plates, bearing plates, showing materials, sizes, welds, embedments, projections, reference elevations etc.
- f. Shear transfer details between elements of the lateral load resisting system clearly defined.

7.5.4.6 Schedules

- a. Schedules for beams, columns, lintels, joists, trusses, frames, piles, caissons, footings, pile/caisson caps, pile/caisson capacities/loads (vertical and horizontal), grade beams, slabs, connections, bracing, etc.

7.5.4.7 Other Drawings

- a. Layout of structural systems for special fabrications and construction such as space trusses/frames, long span trusses, post- and pre-tensioned systems, shells, towers, fabric structures, etc.

7.5.4.8 Seismic Anchorage Of Pipes, Ducts And Equipment

The project drawings shall explicitly detail the support and seismic anchorage and restraint for all equipment that exceeds 400 lbs (180 kg) and building/utility systems. Where it can be shown that unrestrained movement can be tolerated without damage to equipment or system elements, restraint need not be provided.

- a. Details shall include the size and embedment of bolts and anchors as well as sizes and connections for structural support elements.
- b. Suspended equipment shall be supported from structural members, rather than from floor or roof decks.
- c. Stud walls supporting equipment shall be provided with multiple studs and backing plates.
- d. If precise dimensions and weights of equipment are unknown, anchorage details shall be based on the best knowledge available, and may be modified during construction if original assumptions prove to be invalid.

- e. Support and restraint of pipes, ducts and conduit of moderate size may be in accord with the SMACNA “Guidelines for Seismic Restraints of Mechanical Systems and Plumbing piping systems” or with another approved set of seismic restraint guidelines.
- f. Where external vibration isolators are used on equipment, the isolators must be anchored to resist seismic lateral forces.
- g. Where equipment is placed on computer access floors, the equipment must be anchored through the access floor to the structural floor below, unless the access floor system is specifically designed to resist the horizontal and vertical equipment forces.
- h. If it is known that equipment shop drawings will provide seismic anchorage details and that the construction price will include the cost of such anchorage, the anchorage need not be detailed on the project drawings, if a statement is made on the drawings that anchorage will be per approved shop drawings.

7.5.4.9 Precast Concrete Wall Panels

Precast concrete wall panels used as lateral load resisting elements shall be designed as independent elements with no forces transfer across joints.

7.5.4.10 Metric Reinforcing Steel

For projects that use metric dimensions (S.I. units) reinforcing steel must be sized as soft metric conversions of inch-unit bars, i.e. #10, #13, #16, #19, #22, #25, #29, #36, #43, or #57.

7.5.4.11 Design Wind Pressure

- a. The minimum wind velocity to be used in design shall be 80 mph (130 km/hr) per MIL-HDBK-1002/2.
- b. Within ¼ mile (400 meter) of the shoreline, all wind designs shall be based on exposure “D” forces per U. B. C. section 1614 and Table 16-f. Wind Design for inland locations may be based if exposure “C” if such an assumption is justified.

7.5.4.12 Moisture Content

- a. Dimension lumber shall have a maximum moisture content of 19 percent when delivered to the job site.

- b. Lumber with minimum nominal dimensions of 5 inches or greater may have a maximum moisture content of 25 percent when delivered to the job site.

7.5.4.13 Roof Investigations

- a. Roofing investigations shall include examination of equipment, support and anchorage of all roof mounted equipment. When reroofing has occurred, existing equipment that is not properly secured, shall be re-anchored.
- b. If a new roof is installed, that weighs more than the replaced roof, the capacity of the affected framing members shall be checked, and if members are over stressed, it shall be reinforced.

7.5.5 Mechanical Drawings

Include the following:

- a. Plot or Site Plans.
- b. Large Scale Plot or Site Plan.
- c. Mechanical Plans.
- d. Large Scale Mechanical Plans.
- e. Elevations and Sections.
- f. Details.
- g. Isometric and Schematic Diagrams.
- h. Control Diagrams.
- i. Sequence of Operations.
- j. Equipment Schedule.
- k. Equipment Seismic Anchorage.

7.5.5.1 Plot Plan

Required for projects with extensive external mechanical systems, such as power plants, central heating plants, and steam distribution systems. Plot Plans shall:

- a. Be drawn to as large a scale as possible, providing the scale is adequate to show initial installation and future maintenance. Scale shall not be smaller than 1"=50', 1:500.
- b. Show all new utility systems, existing systems, and points of connection.
- c. Show all new and existing structures.
- d. Show dimensions of new systems from a permanent reference point on the project site.
- e. Profiles shall be plotted on the same sheet and directly underneath the plan for all outside underground mechanical piping systems. Indicate invert elevations, slopes, and finish grades.

7.5.5.2 Large Scale Plot Plans

Provide when outside mechanical systems are so extensive as to preclude their indication at a reasonable scale on a single plan. In this case, the Plot Plan shall serve as a Key Plan.

7.5.5.3 Mechanical Plans

Provide for each floor, as well as for foundation, attic, and roof spaces containing equipment and or piping. Mechanical Plans shall:

- a. Be drawn at a scale not less than 1/8"=1'0", 1:100.
- b. Include legends, notes, etc. to assure clarity.
- c. Show provisions for controlling expansion and anchoring of piping and ductwork.
- d. Not combine HVAC work with Plumbing system work without the specific approval of the PL.

7.5.5.4 Large Scale Mechanical Plans

Provide for Mechanical equipment rooms. Large Scale Mechanical Plans shall:

- a. Be drawn at a scale of 3/8"=1'0", or 1/2"=1'0", 1:25.
- b. Include equipment in the room drawn to scale.
- c. Include piping in the room over 3", 75 mm diameter drawn to scale using double lines; piping 3", 75 mm and less can be shown single line.

- d. Identify (using dashed lines for example) adequate space for maintenance, including removal of tube bundles, etc.

7.5.5.5 Elevations/Sections

Provide when vertical dimensions and/or potential interferences are significant in the design. The scale of the elevation/section shall be large enough to clearly show the characteristics of the system, and to allow accurate take-offs of vertical lengths and fittings.

7.5.5.6 Details

Show adequate details to enable the contractor to properly fabricate, assemble, install, attach, and suspend the equipment and piping that is shown on the plans, sections and elevations. Key the details to the other drawings using the bubble system described elsewhere in this chapter.

7.5.5.7 Isometric And Schematic Diagrams

Include piping, equipment configurations, flow direction, and connection points. The scale of the diagrams shall permit easy tracing of the fluid (liquid and gaseous) flow paths.

7.5.5.8 Control Diagrams

- a. Indicate the function of the control systems involved.
- b. Identify the type of controls (pneumatic, electronic, DDC).
- c. Clearly show the limits of the system and the items being controlled.
- d. Be coordinated with the Electrical drawings as well as the Mechanical drawings to ensure all of the electro-mechanical devices function together.

7.5.5.9 Sequence Of Operation

Provide a complete, step by step, written sequence of operation explaining the control system logic. It is preferred that this sequence be shown on a drawing next to the control diagram, however, it may be shown in the specification. The sequence of operation shall:

- a. Be consistent with the control diagram.
- b. Identify values for the set points (for start-up, normal running conditions, shutdown, etc.)
- c. Define emergency conditions and procedures.

7.5.5.10 Equipment Schedules

Show separately and include:

- a. Name, location, and identifying symbol of each major piece of equipment.
- b. Engineering data (flow, pressure, temperature, special operating conditions, etc.).
Note: this information need not be totally complete at the 45% submittal.
- c. Electrical requirements for equipment requiring electrical power (voltage, amperage, phase, frequency, horsepower, etc.).

7.5.6 Plumbing Drawings

Include the following:

- a. Plot or Site Plans and Profiles.
- b. Large Scale Plot or Site Plans.
- c. Plumbing Plans.
- d. Large Scale Plumbing Plans.
- e. Elevations and Sections.
- f. Details.
- g. Isometric and Schematic Diagrams.
- h. Equipment Schedule.
- i. Seismic Anchorage for Equipment.

7.5.6.1 Plot Plan

Plumbing systems, such as central domestic hot water plants. Plot Plans shall:

- a. Be drawn to as large a scale as possible, providing the scale is adequate to show initial installation and future maintenance. Scale shall not be smaller than 1"=50' or 1:500.
- b. Show all new utility systems, existing systems, and points of connection.

- c. Show all new and existing structures.
- d. Show dimensions of new systems from a permanent reference point on the project site.
- e. Profiles shall be plotted on the same sheet and directly underneath the plan for all outside underground piping systems.
- f. Indicate invert elevations, slopes, and finish grades.

7.5.6.2 Large Scale Plot Plans

Provide additional large scale Plot Plans where outside plumbing systems are so extensive as to preclude their indication at a reasonable scale on a single plan. In this case, the Plot Plan shall serve as a Key Plan.

7.5.6.3 Plumbing Plans

Plumbing Plans are required for each floor, as well as for foundation, attic, and roof spaces containing equipment and or piping. Plumbing Plans shall:

- a. Be drawn at a scale not less than 1/8"=1'0", 1:100.
- b. Include legends, notes, etc. to assure clarity.
- c. Show provisions for controlling expansion and anchoring of piping.
- d. Not combine HVAC work with Plumbing system work without the specific approval of the PL.

7.5.6.4 Large Scale Plumbing Plans

Large scale Plumbing Plans shall be submitted for equipment rooms. Large scale plans shall:

- a. Be drawn at a scale of 1/2" = 1'0", or 1:20.
- b. Include equipment in the room drawn to scale.
- c. Include piping in the room over 3", 750 mm diameter drawn to scale using double lines; piping 3", 750 mm and less can be shown single line.
- d. Identify (using dashed lines for example) adequate space for maintenance, including removal of filters, chlorinators, etc.

7.5.6.5 Elevations/Sections

Provide elevations and/or sections where vertical dimensions and/or potential interferences are significant in the design. The scale of the elevation/section shall be large enough to clearly show the characteristics of the system, and to allow accurate take-offs of vertical lengths and fittings.

7.5.6.6 Details

Show adequate details to enable the contractor to properly fabricate, assemble, install, attach, and suspend the equipment and piping that is shown on the plans, sections and elevations. Key the details to the other drawings using the bubble system described elsewhere in this chapter.

7.5.6.7 Isometric/Schematic Diagrams

Isometric and/or schematic diagrams showing the piping and equipment configurations, flow direction, and connection points shall be included. The scale of the diagrams shall permit easy tracing of the fluid flow paths.

7.5.6.8 Equipment Schedules

The Equipment Schedules shall be shown separately and shall include:

- a. Name, location, and identifying symbol of each major piece of equipment.
- b. Engineering data (flow, pressure, temperature, special operating conditions, etc).
Note: This information need not be totally complete at the 45% submittal.
- c. Electrical requirements for equipment requiring electrical power (voltage, amperage, phase, frequency, horsepower, etc.)

7.5.7 Electrical Drawings

Include the following:

- a. Notes, Legends, Symbol List.
- b. Demolition Plans.
- c. Site Plans.
- d. Floor Plans.
- e. Diagrams.

f. Schedules.

g. Details, Sections, Elevations.

7.5.7.1 Notes, Legends, And Symbols List

Electrical symbols shall conform to ANSI Y-32.2 and Y-32.9

7.5.7.2 Demolition Plan

Identify electrical work to be demolished.

7.5.7.3 Site Plan

Show new overhead and underground power, street lighting, communications, fire alarm loop system, utility power supply, emergency power supply and distribution systems. Show the relationship of the work in a building with distribution and services to the outside area.

a. Utility Power Supply. Show the source, the voltage, phase and type of system (delta or wye) and if grounded or ungrounded, the number and size of conductors and if single or three-phase.

b. Emergency Power Supply. Show all mechanical and electrical items necessary for satisfactory operation. The electrical details shall indicate the number of units, the capacity of each in KVA, voltage, phase and type of system. The method for starting and transferring load shall be indicated. The ratings of transfer switch, circuit breaker and wiring shall be noted on the drawings.

c. Underground Installation. Show installation and indicate if the cables are direct burial or in ducts. Show cross sections of each different condition. Plans and sections shall indicate all construction in vaults, manholes and handholes. Required sump pumps or drains shall be indicated. Spare ducts shall be stubbed out for future use from all vaults, manholes and handholes. Indicate location of splices, terminators, cutouts, etc. Indicate cable number, use, size, number of conductors, insulation type and voltage rating for each cable. Show duct bank profiles.

d. Overhead Installations. Locate on the site plan with notations indicating system voltage; size of conductors; location, size and type of transformer banks; pole line switches; lightning protection; and grounding. Elevations, details and material lists shall be provided to identify and describe poles, height, class, cross arms, pole line hardware, transformer mounting and separation. Cross arm details shall include length, size, and number of pins.

7.5.7.4 Floor Plans

In addition to the 45% submittal requirements include the following:

- a. Intrusion Detection System (IDS).
- b. Any other special connections to outside systems.
- c. Locations of entering conduits and service racks.
- d. Circuits and feeders.
- e. Conductor by size, number, voltage and type of insulation.
- f. Conduit size and type.
- g. Telecommunication System.
 1. Circuits
 2. Conductors/cable by size, number, voltage, and type of insulation.
 3. Conduit size and type.

7.5.7.5 Diagram

- a. Riser Diagram. Detail communication/signal systems, the interconnection between panels and equipment, and connection to supply. Notations shall indicate the use, rating and location of panel and equipment.
- b. Single-Line Diagrams. Use this type of diagram to simplify understanding of power. Use single lines and simplified symbols to indicate the course and component devices or parts of the electrical circuits.
- c. Full-Line Diagram. Show all phases or polarities of the electrical system such as generator and transformer windings, busses, feeder circuits, distribution branch circuits, control circuits, and all switching-control-relay-metering equipment. Label and indicate size of equipment, busses and conductors, etc.
- d. Relay and Control Circuits Diagrams. Show in straight line without regard for physical relationships, all circuits and devices, elements of any equipment and its associated apparatus. Where the circuit function is inherently in a definite sequence, the sequence shall be indicated.

e. Process and Instrumentation Diagrams. Include process and instrumentation diagrams to indicate the extent of instrumentation and automation.

7.5.7.6 Schedules And Tables

Identify circuits, protective devices, ratings, loads, phasing, controls, instrumentation, and other pertinent information concerning the installations.

- a. Panelboards. Include breakers for feeders and branches of suitable rating. Indicate if cabinets are flush or surface type. In a table indicate location of panel, circuit breaker number, use, load, breaker size and type; a column of this table may be used to describe feeder and branch circuit wiring.
- b. Lighting Fixtures. Show with approximate dimensioned sketches and description; this shall include the method of hanging and mounting height. Include aligners, special disconnecting fittings or ballasts. If the fixture is modified, supply a detail and notes to convey the description so that the desired item is in no way limited to one manufacturer.
- c. Special Equipment. Identify by a symbol with a number and/or name. Indicate electrical ratings and include data to indicate the type and size. Projects involving the installation and interfacing of special equipment or providing services to such equipment shall be detailed to final termination point indicating clearly where work of others begins. Provide a schedule keyed to the floor plan(s) to identify all Government furnished equipment.

7.5.7.7 Sections And Details

- a. Show location, state size and type and indicate all necessary construction data for transformers, breakers, switches, cutouts, voltage regulators, cubicles, feeders, control wiring, lightning protection, potheads, and lighting fixtures. Detail connections to power supply, feeders and grounds.
- b. Substations and switchgear installations shall include plans, details, elevations, and diagrams that show and describe all meters, instrument transformers and controls, remote or local. Show all connections to grounds, existing facilities or to equipment supplied by others. Show future expansion.
- c. Show seismic anchorage details for the attachment and anchorage of all electrical equipment and fixtures.

7.5.8 Cathodic Protection

Include the following:

- a. Notes, Legends and Symbols List.
- b. Site Plan.
- c. Diagrams.
- d. Details & Sections.

7.5.8.1 Site Plan

Show all existing and proposed cathodic protection systems. Show all metal structures to be protected by new Cathodic Protection Systems. Include the source, voltage, phase. Show location of handholes.

7.5.8.2 Diagrams

Detail the interconnection between panels and equipment and connection to supply. Label and indicate size of equipment and conductors and show electrical ratings.

7.5.9 Fire Protection Drawings

7.5.9.1 Water Distribution

- a. Location and size of existing or new sprinkler system supply mains, new fire hydrants, valves, sprinkler risers, etc.

7.5.9.2 Fire Rated Walls, Doors And Exits

- a. Show and identify fire rated walls, partitions, doors and windows.
- b. Show all exits to building exterior and mark the route of travel and travel distance from any point in a room or portion of the facility to the exits.

7.5.9.3 Gaseous Type Extinguishing Systems

- a. Location of the storage cylinders, control panel and source of AC power to the control panel. (To be tapped off ahead of the main disconnect through a fused disconnect).
- b. Location of warning signs/devices, detectors, manual release stations and locations of auxiliary functions.
 - 1. HVAC shut-down.
 - 2. Power shut-down.

- c. Areas to be protected by these systems.

7.5.9.4 Galley/Kitchen Hood Extinguishing Systems

- a. Location of the storage cylinders, warning signs/devices, manual release stations and auxiliary functions.

1. Gas shut-down.
2. Power shut-down to be via a shunt-trip breaker.

- b. Areas to be protected by these systems.

7.5.9.5 Wet-Pipe Fire Sprinkler Systems

- a. Location of the riser assembly, the water motor gong and the fire department connection.

7.5.9.6 Pre-Action/Deluge Systems (in addition to 7.5.9.3 above)

- a. Location of the detection system control panel, detectors, and areas to be protected by these systems, and location of the source of AC power to the control panel, (to be tapped off ahead of the main disconnect through a fused disconnect).

7.5.9.7 Fire Pumping Systems

- a. Location in noncombustible shelters, if exterior or fire rated construction, if interior.
- b. Single line layouts per NFPA No. 20.
- c. AC power supplies from controller connection to the electrical distribution system and power arrangement per NFPA No. 20.
- d. Locations of the controllers, pumps, test headers, pressure relief valves, pressure relief discharge lines, and by-pass lines.

7.5.9.8 Fire Alarm Systems

- a. Location of the fire alarm control panel, (to be in a normally occupied location), manual pull stations and audio/visual horns.
- b. Location of the Master Box/Transmitter and annunciator panel/interface panel.

- c. Locations of the fire protection system control panels and fire protection system pressure switches.
- d. Areas to be protected by the automatic detection systems, if required. The locations of these devices are not to be shown on the drawings.
- e. Location of the source of AC power to the control panel, (to be tapped off ahead of the main disconnect through a fused disconnect.)
- f. Do not show conduit runs, conduit sizes, wire sizes, or wire counts for the interior systems and single line diagrams, unless specifically directed by the Command's Senior Fire Protection Engineer, Code 5718.
- g. Show the location of the connection of the control panel to the Master Box or Transmitter and annunciator panel or interface panel.
- h. Show the location of the station fire alarm loop and a two (2) inch, (51 mm) concrete encased conduit from the Master Box to that location.

NOTES

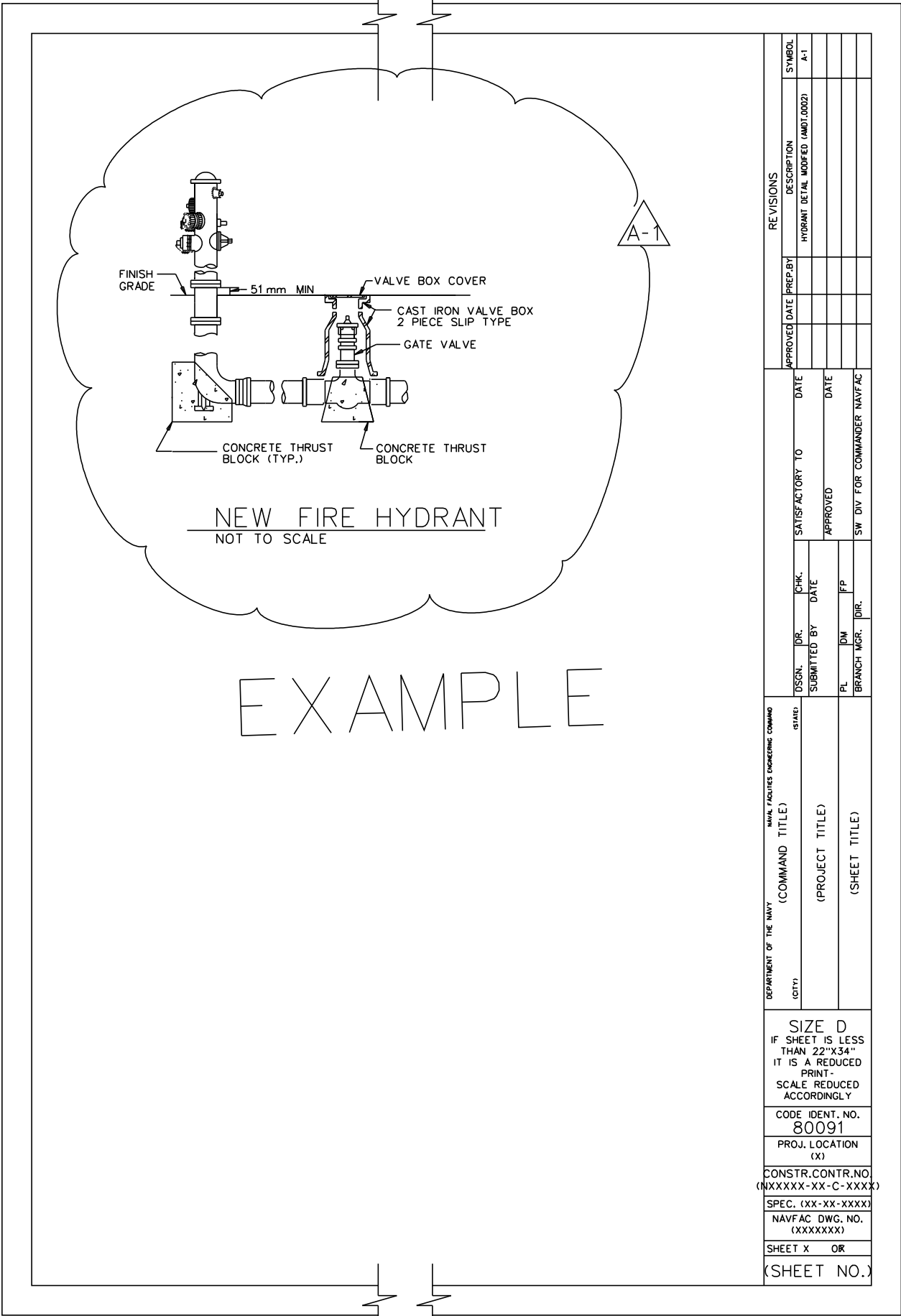

EXAMPLE

REVISIONS		SYMBOL
APPROVED DATE	PREP. BY	A-1

DATE	SATISFACTORY TO
DATE	APPROVED
	SW DIV FOR COMMANDER NAVFAC

DSON.	DR.	CHK.	DATE
SUBMITTED BY		PL	FP
	DM	DIR.	
	BRANCH MGR.		

DEPARTMENT OF THE NAVY	NAVA FACILITIES ENGINEERING COMMAND
(CITY)	STATE
(COMMAND TITLE)	(PROJECT TITLE)
	(SHEET TITLE)

SIZE D
 IF SHEET IS LESS THAN 22"x34" IT IS A REDUCED PRINT-SCALE REDUCED ACCORDINGLY

CODE IDENT. NO.
 80091

PROJ. LOCATION (X)

CONSTR. CONTR. NO. (NXXXXX-XX-C-XXXX)

SPEC. (XX-XX-XXXX)

NAVFAC DWG. NO. (XXXXXXXX)

SHEET X OR (SHEET NO.)

CHAPTER 8. PROJECT SPECIFICATION

8.1 GENERAL DESCRIPTION

NAVFAC MIL-HDBK-1006/1, "Policy and Procedures for Project Drawing and Specification Preparation," provides the requirements and basic instruction on the preparation of project specifications. NAVFAC MIL-HDBK-1006/2, "Policy and Procedures for Guide Specification Preparation," gives guidance to specification writers for the preparation of specifications in the NAVFAC Facilities Guide Specifications (NFGS) format. NFGS are provided on a CD-ROM in various formats:

- a. Standard Navy NFGS Specifications NFGS-00000 (used on most projects).
- b. Short Form Navy Guide Specifications NFGS-SF-0000 (to be used only with permission from a Specification Specialist on the Regional Specialty Support Team (RSST) Code 5716).
- c. Regional Specifications NFGS-R-0000 that are used on all projects administered by Southwest Division. Consult with the RSST, Code 5716 for their use and for any updates.

8.2 SPECIFICATION FORMAT

Unless otherwise approved by the Command, prepare all project specifications using Naval Facilities Guide Specifications (NFGS in the SPECSINTACT/SGML format. This is available in quarterly issues on the Construction Criteria Base (CCB) CD-ROM available from the National Institute of Building Sciences (NIBS). If a NFGS does not exist for a product or system required to accomplish the design, a section shall be developed in the Navy SPECSINTACT format from other sources, such as Corps of Engineers, AIA Masterspec, CSI Spectext or, A-E's existing sources. Number all sections developed by the A-E in conformance with the Construction Specifications Institute (CSI) Masterformat, current (1995) edition. Section numbers of A-E developed specifications shall not conflict with the NFGS system.

8.2.1 Outline Specifications

As a the minimum include the following:

- a. Include each anticipated NFGS Section along with other sections that may be required for the specific project. Provide a brief statement regarding the portion of the work included in each section.
- b. Include all products and systems anticipated to accomplish the project.
- c. Include any special conditions of service and unique site conditions.

8.2.2 Guide Specification Selection

Select specification sections from the "NAVY" menu except for those written specifically for SOUTHWESTNAVFACENGCOM and identified on the menu as "SWDIV." The A-E shall contact Code 5716 for any changes or updates of these sections or any additions to them. Unless specifically directed, the only Division 00 sections requiring editing by the A-E is Section 00102, List of Drawings. The A-E is required to complete a Project Information Form (provided by the Area Focus Team member managing the project).

8.2.3 Guide Specification Issue Dates

The date of issue, or version, of NFGS to be used for each project shall be based on the version that is current at the time of return of the 45% design review comments to the A-E. If there is no formal 45% review, the date shall be determined by the date of award of the 100% design.

8.2.4 SPECSINTACT Specifications

There are currently two different specification programs on the CCB disk. They are:

- a. WINDOWS Program - These programs will no longer be supported in the future and will eventually be removed from the disk. Specifications already produced with this program can be converted to the SGML Program.
- b. SGML Program - This program is currently on the CCB. It is a true Windows program and will be the only program supported after 1997. Specifications starting at the date of issue of this A-E Guide shall be produced using the SGML Program.

8.2.5 Specification Number

A specification number is created from the last two digits in the regional area number, the fiscal year of the project and the last four digits of the construction contract number. For example, the contract number for the Southwest Division is N68711-97-C-1234. The specification number would be **11971234**.

8.3 RESTRICTIVE SPECIFICATIONS

The use of proprietary specifications, "or equal" specifications, extended warranty requirements, and other restrictive requirements are permitted only with written permission from the Command. The A-E shall justify them on the firm's letterhead. Submit this justification request at least 30 days prior to the 100 percent submission, but preferably with the 45 percent submission. The early submissions of these items are necessary as approvals are normally time consuming and may jeopardize the project schedule. See Exhibit 8-A for an example of the required documentation for approval request.

8.3.1 Proprietary Products

If a situation arises in which only one product or system will perform the required function, and the use of proprietary specifying is granted by the Command, then the item shall be specified by the manufacturer's name and model or catalog number followed by the phrase

“Notwithstanding Any Other Provision Of This Contract, No Other Product Will Be Acceptable.”

8.3.2 Or Equal Specification

The use of open proprietary specifying by naming acceptable commercial products followed by the words "or equal" may be permitted with Command approval under the following conditions:

- a. There are no Government Guide Specifications for the item.
- b. The item is a minor part of the construction project.
- c. The item cannot be specified by descriptive, performance or reference standard methods.

Note: In each instance include a minimum of three manufacturers in the description followed by the words "or equal." Describe the essential features of the item in sufficient detail to establish the basis upon which the quality of unlisted products will be determined. The A-E may be requested either prior to bid opening or after award to approve of any “or equal” substitutions.

8.3.3 Extended Warranty Clauses

Do not include special warranty clauses, other than those provided in the Contract Clauses, i.e., a 1-year warranty by the Contractor or manufacturer's standard commercial warranty. Any special warranties require the approval of a Level 1 Contracting Officer. Submit justification for requiring the warranty clause with a copy of the proposed specification.

8.3.4 Experience Clauses

Do not include Contractor experience clauses, other than those provided in the NAVFAC Guide Specifications unless they are required to perform the work required by the specification. Any special experience clause not included in existing NAVFAC specifications requires the approval of a Level 1 Contracting Officer. Submit justification for requiring the experience clause with a copy of the proposed specification.

8.3.5 Pesticides, Herbicides, Fungicides, Etc.

Products of this nature require special approval. For a project using these materials submit the specification section for review prior to the 100 percent submittal. This is necessary to keep the project on schedule as the review will require additional time.

8.3.6 Computer Software For Construction Projects

If software is to be required for the project the paragraph “Agreement to License the Government to Allow Designated Organizations Use of Contractor Data for Government Purposes” and a DD Form 1423, “Contract Data Requirements List,” will need to be

edited and submitted with the A-E Information Form for incorporation into the contract by the Contracting Officer. Contact Code 5716 for instructions.

8.4 STANDARDS

If the Military or Federal Standard references in the REFERENCE portion of PART 1 of the NFGS Sections does not meet the design requirements for the project, appropriate commercial standards should be substituted. If the reference used is not included in the list of references furnished with the issue of the CCB used, the A-E must include the source and telephone number in the project specification's Section 01420, References.

8.5 CRITERIA

The specifications include notes that assist the designer in the editing of the project. Adhere to these notes unless permission is received by Code 5716 and the person managing the project. Refer to the notes in the NFGS for the drawings required for the product or system specified. NFGS may include drawings. Do not include such drawings in the specifications. Appropriate drawings shall be included in the project drawing set.

8.5.1 Product Identification

If any schedule on the drawings or in the specifications refers to a manufacturer's product for comparison insert the following paragraph after each of the schedules included:

"Manufacturer's names, color identification, textures, and patterns listed are for purpose of identification only. Products of any other manufacturer that approximate the color, texture, or pattern are acceptable if they conform to the specifications. Named products are acceptable only if they conform to the specifications."

8.5.2 Construction Category Codes

For Military Construction Projects the specifications require the identification of Category Codes for different types of construction. If these are not furnished to the A-E prior to completing the specifications they will be returned with the 100 percent comments.

8.6 COORDINATION, DRAWINGS, SPECIFICATIONS, COST ESTIMATE

The A-E shall be responsible for coordination between drawings, specifications, and cost estimate. Incomplete and uncoordinated submittals will not be reviewed by the EFD and will be returned for resubmittal with no further extensions or modifications to the contract. Note: The "Success" estimating program used by the Government incorporates a Work Breakdown Structure (WBS) which is based on CSI "Unifomat", a Uniform classification of Construction Systems and Assemblies. Refer to the Interim Edition of "Unifomat", published in 1992, for the relationship of Uniform Construction categories to CSI Masterformat 16 Division specification sections

8.7 BIDDING REQUIREMENTS

Government procurement policies require that a construction award be made within available project funds. The following paragraphs describe procedures that supplement the information found in the NFGS regarding the bidding process.

8.7.1 Project Information Form

The information in this form is used by the Command's contract branch to complete the contractual requirements, Division 00. This form is available from each AFT or Code 5716. The form is to be included with the 100 percent submittal and an updated copy, if required, at the final submittal. This form may be updated as required by changes in the Federal Acquisition Regulations (FAR) or in the contractual sections in Division 00.

8.7.2 Base Bid

The base bid shall by itself provide a complete and usable project.

8.7.3 Additive Bid Items

Additive Bid Items may be required to help assure that a construction award can be made within available project funds. Select work increments for additive bid items that can be separated from the project without rendering the facility unusable. There shall be no more than four additive bid items unless otherwise authorized by the Command. Arrange additive bid items so that the most essential portion of the work is added first. Succeeding items will be cumulative for purposes determining if the project is within the available funds; however, to provide latitude in selection, each additive bid item shall be independent of the others. Command policy is that the total of the additive bid items shall not be more than 25 percent of the base bid. The requirements for additive bid items are included in the Project Information Form.

8.7.4 Unit Price Bid Items

Unit price bid items are used for types of projects where the exact quantities of selected portions of the work cannot be determined prior to performance. State the quantity to be used for evaluating each item. The unit price is contractually enforceable only where the specified quantity of work is within plus or minus 15 percent of the actual quantity. The submission for unit prices is included in the Project Information Form.

8.7.5 Options

If options are required due to funding requirements, consult with the PL on the specific AFT for specific directions. The requirements for options are included in the Project Information Form.

8.8 AMENDMENTS

Prepare amendments in strict conformance with "Amendment Change Order (COR)" instructions furnished by the agency's Specification Specialist. Prepare and submit

amendments and a copy of the amendment on appropriate magnetic media, 3 ½ inch disks, identify processor used. See Exhibit 8-E.

8.9 CHANGE ORDER REQUESTS (COR)

Prepare Change Order Requests in strict conformance with "Amendments and Change Order Request (COR)" instructions furnished by the agency's Specifications Specialist. Compile and submit COR packages and a copy of the COR on appropriate media, 3 ½ inch (90mm) disks, identify program used.

8.10 COMBINING SEPARATE PROJECTS INTO ONE BID PACKAGE

When the decision is made by the Command to combine two or more construction projects into one bid package, one A-E firm will be selected to accomplish the task. See Exhibit 8-C for explanation of the process.

8.11 SPECIFICATIONS PRINT FORMAT

Produce the hard copy using a printer producing characters with a minimum 300 dots per inch (dpi). Use six lines per inch, 10 or 12 point (preferably 12), Sans Serif font, on 20 pound (9-10kg), 8-½ x 11 inch (210mm x 297mm) white cut sheet paper for printing. Use 12 pitch if a fixed pitch is used. Paper with perforated edges is not acceptable. Type throughout the specifications shall be the same size and style. Strikeouts, screening, bolding, underlines, or other embellishments are not permitted. All parts of the specification are considered of equal importance.

8.12 MAGNETIC MEDIA

In addition to hard copy, provide with the 100 percent and final submissions a "Back-Up" copy on SISGML compatible, and preferably 3.5 inch (90mm) disks of the SPECSINTACT Job File using the SPECSINTACT job Back-Up command. Identify each of the disks with the project name, specification number, issue of CCB used, and project location. Include "P" numbers for those projects so numbered. These disks may be used for printing the bid package, therefore they must be able to duplicate the final hard, signed copy submitted. Any disk that appears not to allow a duplicate print will be returned to the A-E for the required corrections.

8.13 SUBMITTALS AND TESTING LIST

Generate the Submittal List, Submittal Register, and Test Report from SPECSINTACT. Identify submittals to be approved by the GOVERNMENT with a "G."

8.14 SUBMITTALS

Prior to printing, the A-E should use the SPECSINTACT error reports for checking and correction errors.

8.14.1 15 Percent And 45 Percent Submittals

The 45 percent submittal shall include an Outline Specification in the format of Exhibit 8-D. Outline Specifications may be required for large, complex projects such as hospitals prior to 45 percent. Verify with the PL of the specific project.

8.14.2 Basis Of Design

Submit in accordance with Chapter 6, Basis Of Design.

8.14.3 100 Percent Submittal

Specifications shall be complete, camera ready, with all elements thoroughly checked and coordinated with the drawings, and with sufficient detailed information to permit accurate bidding and construction of the project. If the project is to be "fast-tracked" where the 100 percent is to be used for advertisement and bids conform to final submittal requirements. Provide the following:

- a. Specifications on magnetic media consisting of backup of the edited job "Pull Files" on disks using the SPECSINTACT system.
- b. Bound hard copies of the specifications. Include cover sheet and required blank forms (NFGS 01330 and 01450). The separately generated project cover sheet on CCB may be included.
- c. Copy of the Submittal Register and Test Reports.
- d. Copy of the Project Information Form.

8.14.4 Final Submittal

Specifications shall be complete, camera ready, with all elements thoroughly checked and coordinated with the drawings, and with sufficient detailed information to permit accurate bidding and construction of the project. Provide the following:

- a. One complete unbound specification manuscript on 20 pound (9-10kg) paper, single spaced, and printed on one side only. Pages with rough edges are not acceptable. Include the required blank forms in the final package for sections 01330 and 01450.
- b. Bound hard copies of the specifications as required in the Scope of Work.
- c. Final specifications on magnetic media consisting of the edited job "Pull Files" on disks of the SPECSINTACT job file using the SGML/SPECSINTACT system.
- d. Final copies of the Submittal Register and Test Report.
- e. The cover sheet shall be stamped by a licensed member of the firm to which the Government awarded the design contract.**

EXHIBIT 8-A

RESTRICTIVE SPECIFICATIONS

APPROVAL REQUEST

1. GENERAL: Make requests to use restrictive methods of specifying in writing to the Project Leader. Letters of request shall include the following:

- a. Project information including Contract No. (N68711-FY-C-XXXX) Project No. (P-XXX), Project Title, and Project Location.
- b. Formal request for the use of restrictive specification in subject contract based on the following data:
 1. Complete description of the item and the manufacturer.
 2. Justification of why the specification must be restrictive. The Command will not act favorably on justifications made solely for the purpose of matching existing products or systems unless the product or system will not function properly if not matched exactly.
 3. Estimated total cost of the contract.
 4. Estimated cost of restrictive items.

EXHIBIT 8-A

EXHIBIT 8-B

GENERAL PROJECT INFORMATION

(By Project Leader)

(To be completed prior to forwarding to A-E for completion)

1. Project Name:

2. Project Number: (P-No, SP-No, ESR-NO,
other)_____

3. Contract Number: N68711-_____-_____-

4. Contract Type: IFB____ RFP____ DESBLD____ Other_____

5. Estimated construction Cost (ECC) \$ _____

6. A-E Firm: _____

7. Point of Contact: _____

8. Phone Number: (_____) - _____ - _____

9. Area Focus Team (AFT) _____

10. Project Leader: _____

11. Phone Number: (_____) - _____ - _____

12. Contract Specialist: _____

13. Phone Number: (_____) - _____ - _____

14. ROICC: _____

15. Phone Number: (_____) - _____ - _____

PROJECT INFORMATION FORM

INFORMATION REQUIRED FOR CONTRACTS

(TO BE COMPLETED BY THE A-E CONTRACTOR)

I INSTRUCTIONS TO BIDDERS/PROPOSERS

1. Does project include unit prices? Yes___ No___

If yes, include the following and coordinate with specification section:

a. Lump sum for all work not covered in the unit price items listed below: _____
\$ _____

b. Unit price per _____ for _____
\$ _____ per _____ x _____ = \$ _____

c. Unit price per _____ for _____
\$ _____ per _____ x _____ = \$ _____
Total Price Base Bid Item 0001 \$ _____

2. Are there also Additive or Deductive Bid items? Yes _____ No _____

What are the additive or deductive bid item(s): _____

If yes, coordinate with Contracts as this requires Contracting Officer approval.

Coordinated: _____ Not Applicable _____ Yes _____ No _____

3. Reference to FAC 5252.214-9301, Notice To Bidders

Does the project include additive bid items? Yes___ No___

If yes, include the following (May be included as an attachment):

- (i) Base Bid Item 0001 shall be the entire work complete in accordance with the drawings and specifications, but not including work indicated or specified to be provided under any of the other bid items.

EXHIBIT 8-B

(ii) Additive Bid Items 0001AA shall be the addition of the following, complete in accordance with the requirements specified hereinafter:

(iii) Additive Bid Items 0001AB shall be the addition of the following, complete in accordance with the requirements specified hereinafter:

4. Reference FAR 52.236.27, Pre-Bid Site Visitation

(Coordinate with Project Leader and Contracting Officer)

Will a Pre-Bid site visitation be required? Yes_____ No_____

If yes, complete the following:

a. Point Of Contact: _____

b. Telephone Number: (_____) - _____ - _____

c. Special Security requirements: _____

d. Other special requirements: _____

5. Reference to FAR 52.217-7, Option for Increased Quantity Separately Priced Line Item.

Will this project have "Option" items? Yes_____ No_____

If yes, requires Contracting Officer's permission. (Coordinate with the Project Leader, and Contracting Officer)

If yes, complete the following: (May be included as an attachment):

(i) Option Item 0001 shall be the addition of the following, complete in accordance with the requirements specified hereinafter:

EXHIBIT 8-B

(ii) Option Item 0002 shall be the addition of the following, complete in accordance with the requirements specified hereinafter:

How long of a period, in days, will the option to award be for? _____

Also, will the option item effect the construction period of the contract?

Yes ____ No ____

If so, explain (Take into consideration the effect of it being awarded (1) with the original bid, (2) at any time during the specified option period, or (3) at the end of the specified option period):

6. Reference FAR 52.236-4, Physical Data

Is physical data (e.g. test borings, hydrographic, weather conditions data, etc.) to be furnished or made available to offerers? Yes _____ No _____

If yes, fill in applicable data:

a. The indications of physical conditions on the drawings and in the specifications are the result of site investigations

by _____

(insert description of investigative methods used, such as surveys, auger borings, test pits, probing, test tunnels, etc.)

b. Weather conditions:

(insert a summary of weather records and warnings)

c. Transportation facilities _____

(insert a summary of transportation facilities providing access to and from the site, including information about their availability and limitations)

d. Insert other pertinent information: _____

7. Pre-Proposal Conference (Design/Build).

Is a pre-proposal conference to be scheduled? Yes____ No ____

If yes, complete the following:

a. Scheduled for (day) _____ Date _____

b. Location: _____

c. Point of Contact: _____

d. Telephone Number: (_____) - _____ - _____

8. FAR 52.252-3, Alterations In Solicitations

(Consult with Project Leader, and/or Contracting Officer if this information is required or if there will be any special conditions for proposals)

a. Will technical proposals be in several parts? Yes____ No____

If yes, describe _____

b. Will costs be separated from technical requirements? Yes ___ No ___

c. Will proposal require an Administrative breakdown? Yes ___ No ___

d. Will proposal require an Organization breakdown? Yes ___ No ___

e. Are instructions on how to breakdown costs required? Yes ___ No ___

f. Will there be specific or special format for submissions? Yes ___ No ___

If yes to any item above, attach description.

EXHIBIT 8-B

II INFORMATION FOR EVALUATION SECTION 00202

1. "Source Selection." If this project is an RFP and is using evaluation of bids for selection, complete this section.

"EVALUATION FACTORS FOR AWARD." _____

III INFORMATION FOR SECTION 00452

1. Reference FAR 52.223-4, Recovered Material Certification

Does this contract specify the use Recovered Materials? (i.e. materials that have been collected or recovered from solid waste per FAR 23.402)

Yes _____ No _____

If yes, describe _____

IV INFORMATION FOR SECTION 00102

1. A-E edits entire section "List of Drawings" in SPECSINTACT and submits it complete at the 100% and final submittal.

Section 00102 included: Yes _____ No _____

V INFORMATION FOR SECTION 00710 OR 00720

1. Reference DFARS 252.210-7000, Brand Name or Equal

Does the project include any Brand Name or Equal statements? Yes _____ No _____

If yes, requires prior approval by a Level One Contracting Officer. Provide the following:

Description: _____

Spec Section and/or Dwg. No.: _____

Spec Para. or Drawing View: _____

Obtain copy of justification form from PL. Will require approval of a Level One Contracting Officer. Attach completed form.

2. Reference FAR 52.211-10 Commencement, Prosecution, and Completion of Work and Alternate I

a. Complete the entire work ready for use not later than _____ calendar days after notice to proceed.

b. Phasing sequence as follows: _____

3. Reference FAR 52.223-3, Hazardous Material Identification and Material Safety Data

Will this contract require delivery of hazardous material that will remain in place when the project is completed which the station requires Material Safety Data Sheets? Yes _____ No _____

a. Location of hazardous material: _____

b. Material Safety Data Sheet information: _____

4. Reference FAR 52.225-5, Buy America ACT - Construction Materials

Does the project have any exemptions to the Buy America ACT? Yes ___ No ___

Prior approval is required for an exemption. If yes, fill in table below:

Description: _____

Spec Section or Drawing No.: _____

Spec Paragraph or Drawing View: _____

EXHIBIT 8-B

5. Does this project specify any Class I Ozone Depleting Substance (ODS)?

Yes_____ No_____

Attach memorandum for contract file verifying the specification has been reviewed for these substances. When there is no alternative to using ODS, provide technical certification that no other product is available to meet requirements. Some products do have waivers, coordinate with the Project Leader. Use of these products requires the Contracting Officer's approval.

VI INFORMATION FOR SECTION 00711 OR 00721

1. Reference FAR 52.236-14, FAC 5252.236-9304, and FAC 5252.236-9305

- a. Are utilities furnished by the Government or the Contractor? Yes ___ No ___
- b. Will there be any cost to the Contractor for utilities furnished by the Government?

Yes ___ No ___

If yes, complete the following:

Electric	\$_____	per _____
Water	\$_____	per _____
Gas	\$_____	per _____
Other _____	\$_____	per _____

VII INFORMATION REQUIRED BY SECTION 00830

1. In what city, county, state, and on which base is the project located? Complete the following:

- a. City: _____
- b. County _____
- c. State _____
- d. Base _____

VIII SOFTWARE AND COMPUTER REQUIREMENTS

1. Reference Computer Data and Software Clause, DOD FARS 52.227-7013, and Data Requirements Clause, DOD FAR 52.227-7031

Does this project require any computer software? Yes_____ No_____

If yes, complete the following:

Purpose: _____

Description: _____

Specification Section: _____

Project may require completion of Form

DD Form 1423, Contract Data, and DD Form 1664, Data Item Description, may be required, consult with Project Leader and Contracting Officer. RFPs require the use of DD Form 1423.

If these forms are required, complete and attach.

2. Computer Hardware

Does this project require any computer hardware? Yes_____ No_____

If yes, complete the following:

Purpose: _____

Description: _____

Specification Section: _____

May require review by Counsel and/or Information Systems Support, ADP services, for any special requirements. Coordinate with PL, Contracting Officer, and user.

EXHIBIT 8-B

IX PROPRIETARY PRODUCTS

1. Does this project specify any proprietary items either directly or indirectly?

Yes _____ No _____

If yes, complete the following: _____

Indicate where these items can be found in the drawings and specifications.

Description: _____

Spec Section or Drawing No. _____

Spec Paragraph or Drawing View: _____

Obtain copy of justification form from PL. Will require approval of a level one Contracting Officer. Attach the completed form.

X Government Furnished Equipment Yes _____ No _____

If yes, please identify equipment: _____

Indicate where these items can be found on the drawing and specifications

*****END

EXHIBIT 8-C

PREPARATION OF AMENDMENTS

1. GENERAL: NAVFAC regulations require that amendments must be in the possession of each prospective bidder a minimum of ten (10) calendar days prior to the bid opening date. Failure to meet this deadline will result in bid postponement. Amendments prepared by the A-E must be submitted to the PL prior to the bid opening date to allow for review, processing, printing and distribution by the COMMAND. The amendment must be submitted in time to allow for printing and mailing so the bidders receive it at least 10 days prior to bid opening. Full size drawing reproductions take longer to reproduce. If full size drawings are included increase the lead time required as advised by the PL.

2. FORMAT: Amendment items must be in the same order as in the subject project specifications' sections. Changes to specification shall be first followed by new specifications, verbal descriptions for drawing revisions, sketches (if allowed), and finally drawings. Minor changes to drawings may be made by written descriptions and by sketches on 8-1/2 x 11 inch paper. Sketches shall contain no more than one detail the same title block as the drawing revised. Major changes may require re-issue of existing specification sections and drawings or the addition of new specification sections and drawings. Include changes in order of NAVFAC drawing number and in specification number. Attach new or revised sections to back of amendment before any drawing or sketches.

3. PAGE FORMAT: The COMMAND will provide the cover sheet (Standard Form30) for all amendments. The A-E shall provide the remainder of the amendment beginning with page 2. Provide the following title and numbering system for each sheet:

Project Number, Title, and Location Specification Number (Upper left hand corner)
Amendment Number (Upper right hand corner)

Section Number or Sketch Letter(If required)
Pagination
(Bottom center of page)

Amendment Numbers will be assigned by the PL and will begin with "0001" for each project. Page numbering will appear as follows and the first page shall always start with "2." Changes shall be in the same order as the specifications.

When an amendment includes a new specification section, the amendment number will be in the upper right hand corner below the specification number as previously illustrated, and the page numbering at the bottom of each sheet will appear as follows (normal specification pagination):

Section Number - Section Page Number

For Example:

SECTION 08110 PAGE 6

4. SAMPLE FORMAT: Following paragraphs illustrate required sequence of changes included in the amendment. On each page include headers and footers described above.

4.1 INTRODUCTION: Include the following paragraph to start amendment:

The following changes shall be incorporated into the original issue of plans and specification for this project:

Prepared by: [A-E initial and date]

4.2 CHANGES TO THE TABLE OF CONTENTS:

TABLE OF CONTENTS

DIVISION 01 - GENERAL REQUIREMENTS

Following Section 01500, Temporary Facilities and Controls, add the following:

Section 01781 - Operation and Maintenance Requirements

4.3 PROJECT SPECIFICATION CHANGES: Clarity in the identification of items to be changed and in the changes themselves is of the utmost importance in an amendment. The following rules should be followed:

Rule 1: When identifying paragraphs use the full number such as "2.1.2.3."

Rule 2: The first two or three words of a paragraph title should be sufficient for identification. However, the writer should double check for paragraphs with similar titles and use full titles if there is any chance for confusion.

Rule 3: When making a small change which involves just a number, word or small group of words, identify the line or sentence number within the paragraph.

EXHIBIT 8-C

a. Adding Paragraphs or Subparagraphs:

SECTION 03300
CAST-IN PLACE CONCRETE

1.2 SUBMITTALS

Add the following paragraph:

1.2.1 SD-05, Design Data

a. Concrete Mix Design G

Submit for each type of concrete included in the work.

b. Word Changes:

SECTION 15182
REFRIGERANT PIPING

2.1.1.2 Copper Pipe and Fittings: In line 7, delete “bronze” and substitute “galvanized steel.”

c. Omitting Paragraphs or Subparagraphs:

SECTION 02742
BITUMINOUS HOT MIX PAVEMENT

2.2 ASPHALT CEMENT

Delete this paragraph in its entirety and substitute the following:

2.2 NOT USED

d. Adding new sections:

EXHIBIT 8-C

SECTION 01781

OPERATION AND MAINTENANCE REQUIREMENTS

Add this section accompanying this amendment in its entirety.

e. Replacing existing sections:

SECTION 01330
SUBMITTALS

Replace this section in its entirety with the accompanying "SECTION 01330, SUBMITTALS, revised month-day-year."

NOTE: Title the new section on the specification, only required on first page, as follows:

SECTION 01330
SUBMITTALS revised mm/dd/yy (or)
revised mm/dd/yy

4.4 DRAWING CHANGES:

a. Adding drawings:

SECTION 00102
LIST OF DRAWINGS

1.2 CONTRACT DRAWINGS

Add the following drawings to the list of drawings, making a total of 23 drawings. Drawings shall be dated:

<u>NAVFAC DRAWING NUMBER</u>	<u>TITLE</u>
8088123	Revised Floor Plan
8088136	Lighting Fixture Details

EXHIBIT 8-C

b. Revising Drawings:

SECTION 00102
LIST OF DRAWINGS

1.2 CONTRACT DRAWINGS

The following revised drawing(s) supersede the drawings of the same number and title from the original issue as shown on the list of drawings in the specifications. These drawings are issued with this amendment. Drawings shall be dated Month-Day-Year:

<u>NAVFAC DRAWING NUMBER</u>	<u>TITLE</u>
8088191	Foundation Plan, Revised (Date)
8088192	Floor Plan, Revised (Date)

NOTE: Complete the "Revisions" block in the upper right hand corner of drawings with letter designation, description, name of prepare, and date. The "Approved " block shall be completed by the PL. Note revisions by distinctive symbols at appropriate locations on the drawing.

c. Written Changes to Drawings:

SECTION 00102
LIST OF DRAWINGS

1.2 CONTRACT DRAWINGS

The changes and/or revisions following shall be made to the drawings listed herein. Prospective bidders are requested to transfer changes and revisions to their bid sets. The successful bidder will be required to post each change or revision to the RECORD DRAWINGS which he must maintain at the jobsite in accordance with the clause "RECORD DRAWINGS" in the specifications. No new drawings will be issued reflecting these changes:

<u>NAVFAC DRAWING NUMBER</u>	<u>TITLE</u>
8088193	Plan and Details

DESCRIPTION OF CHANGE

EXHIBIT 8-C

On the foundation plan notes, note No. 3, change "the bottom of footing ..." to "The top of footing...".

d. Sketches: When written changes to the drawings are not feasible and the changes are minor in nature, letter size sketches may be issued by amendment. Details and other information shown on the sketch sheet shall be coordinated with the drawings. The title block shall contain the same information as the title block on the project drawings. Include on each sheet the headers and footers described above:

SECTION 00102
LIST OF DRAWINGS

1.2 CONTRACT DRAWINGS

NAVFAC DRAWING NUMBER

TITLE

80881914

Site Plan and Details

DESCRIPTION OF CHANGE

Add details "Revisions to Utility Site Plan" and "Detail of Interceptor Catch Basin" as shown on Sketch A, accompanying this amendment.

EXHIBIT 8-C

EXHIBIT 8-D

PREPARATION OF CHANGE ORDER REQUESTS (COR's)

1. GENERAL: Change Order Requests are identified alphabetically with the order assigned sequentially in the field by the ROICC. Additions, changes and deletions that are incorporated into Change Order Requests shall appear in the same order as their original position in the project manual and drawings. Change Order Requests must include all previous changes made by amendment.

2. PAGE FORMAT: Unlike amendments, the Change Order Request (COR) requires a cover sheet provided by the A-E. The format shall conform to the following example:

Specification Number
COR "___"
(Upper right corner)

The following changes shall be incorporated into the project documents for this project:

Prepared by: [A-E initial and date]

PROJECT TITLE
P-123

at the

STATION
CITY, STATE

In this location provide a brief, self contained description of the Change Order Request (COR)

Center the following at the bottom of each page:

COR "___"
Pagination

EXHIBIT 8-D

Example, start the COR with page number "1":

COR "A"
Page 1 of 6 pages

2. When adding complete, new specification sections in a COR, place the section title, specification number, and COR letter as follows:

Project Number, Title, and Location
(Upper left corner)

Specification Number
COR "___"
(Upper right corner)

Bottom of page centered:

Section Number - Section Page Number
Pagination

Example:

SECTION 08110 PAGE 6
Page 8 of 13 Pages

3. CHANGE ORDER REQUEST CONTENT: A typical COR package would include items in the following sequence, format is similar to an amendment:

- a. Table of Content changes.
- b. Changes, new, or additional specification sections in numerical order.
- c. New drawings.
- d. Deleted drawings.
- e. Revised drawings.

4. DRAWINGS: Only full size reproducible drawings are allowed.

EXHIBIT 8-D

EXHIBIT 8-E

PROCEDURES FOR COMBINING SEPARATE PROJECTS

1. GENERAL: Individual projects prepared by one or more A-E Firms may be combined for the purpose of securing a single bid. If the Command determines to combine separate projects, the A-E selected to combine the projects shall prepare the bid package under the direction of the PL and in conformance with the following guidelines:

- a. Identify individual projects as Part "A" and Part "B" or Part "X," in alphabetical order as required, for the combined project.
- b. Package the bidding documents and Division 1 specification sections together and identify as Part "A"/Part "B"/Part "X" on each sheet. Identify the technical specifications including Division 2 through Division 16 as Part "A" or Part "B" or Part "X," as required, on each sheet.

1.1 SPECIAL CASES

In some case the use of the "Parts" designation may not be appropriate. In these case the PL will furnish guidance in packaging the project documents.

2. TITLE PAGE: Prepare new title pages clearly identifying the required parts, project titles, job order numbers, and PL. The cover sheet for the entire package shall contain the signatures of all A-E firms responsible for each part. This is to signify that all A-Es agree that the Division 01 specifications apply to each of their parts technical specifications. Place individual cover sheets for each part as the first page of each of the parts.

3. TABLE OF CONTENTS: Prepare separate Tables of Contents for the bidding documents and Division 01 specification package and each of the technical specification packages. Identify in the Table of Contents with the Division 01 specifications that the Table of Contents for the technical sections for each part is located at the beginning of each part's specifications.

4. REPORTS: Prepare separate Submittal Registers and Test Reports for each part and the Division 01 specifications.

5. DRAWINGS: Label all drawings in the lower right hand corner, above the title block, with the appropriate part designation as required.

EXHIBIT 8-E

PROJECT NAME, NUMBER
at the
LOCATION (IF DIFFERENT THAN OTHER PARTS)
(PART A)

PROJECT NAME, NUMBER
at the
LOCATION (IF DIFFERENT THAN OTHER PARTS)
(PART B)

PROJECT NAME, NUMBER
at the
LOCATION (IF DIFFERENT THAN OTHER PARTS)
(PART C)
at the

NAVAL STATION, SOMEWHERE
CITY, STATE

If parts are by different A-Es, complete following:
DESIGNED BY:

PART A _____
PART B _____
PART C _____

SPECIFICATIONS
PREPARED BY:
(name of firm responsible for combining projects)
NAME OF FIRM
ADDRESS
CITY, STATE

SUBMITTED BY: _____ DATE: _____
APPROVED BY: _____ DATE: _____
Project Architect/Engineer: _____

11yy####
P-#/Title (Part A), P-#/Title (Part B), P-# (Part C)

11YY####
PART A,B, & __

EXHIBIT 8-E

PROJECT TABLE OF CONTENTS

DIVISION 01 - GENERAL REQUIREMENTS

01010	SUMMARY OF WORK
01025	MEASUREMENT AND PAYMENT
#	APPROPRIATE TITLE
#	title
#	title
etc.	etc.

DIVISION 02 - THROUGH - DIVISION - 16

AN INDEX OF TECHNICAL SECTIONS PRECEDES EACH OF THE FOLLOWING PARTS:

PART A:	TITLE
PART B:	TITLE
PART C:	TITLE

- End of Project Table of Contents --

PART A or PART B or PART C
PROJECT TABLE OF CONTENTS PAGE 1

EXHIBIT 8-E

EXHIBIT 8-F

OUTLINE SPECIFICATIONS

1. PAGE FORMAT

Include as header each page of Outline Specification:

Project Title and Location

Specification No.

Include as a footer bottom center each page:

SECTION NO. and or GENERAL REQUIREMENTS
Pagination

2. GENERAL REQUIREMENTS, DIVISION 01

Include as applicable with brief descriptions:

GENERAL REQUIREMENTS

- a. Brief description of the project.
- b. Codes or special Requirements.
- c. Phasing required.
- d. Scheduling and duration.
- e. Special project procedures.
- f. Government furnished and installed equipment.
- g. Government furnished and Contractor installed equipment.
- h. Coordination requirements.
- i. Additive bid items, unit prices, and options.
- j. Special security requirements.
- k. List of Division 01 sections to be included.

3. TECHNICAL SECTIONS

EXHIBIT 8-F

Include as applicable for each section:

SECTION NUMBER
TITLE

- a. System Description: Use descriptions required to explain characteristics or special requirements. Especially required if not indicated on drawings or requirements not included in product description.
- b. Submittals: Describe any special submittals, testing, or calculations.
- c. Quality Assurance: Describe special project requirements such as mock-ups, samples, or special testing required.
- d. Warranty: Describe any special warranties.
- e. Components: Describe materials and manufactured products, equipment, finishes, and components. Use performance requirements, quality of finishes, or reference standards if appropriate.
- f. Fabrication: Describe special shop or factory fabrication requirements, special finishes, or special tolerances.
- g. Preparation: Describe unusual or special requirements.
- h. Installation: Describe special installation requirements or tolerances more restrictive than normal standards. Reference trade association standards.
- i. Field Quality Control: Describe field test requirements for installed products.
- j. Schedules: Identify where products not easily shown on drawings are used. Include simple schedules for special finishes or quality and special hardware.

EXHIBIT 8-F

EXHIBIT 8-G

PREPARATION OF AMENDMENTS

1. PURPOSE OF AMENDMENTS (ADDENDA):

A document issued during the bidding period to make changes in the “Bidding Documents”.

2. REASONS FOR AMENDMENTS:

There are many reasons for amendments. However, the most common is to amend the bidding documents as follows:

2.1 To revise Contract Drawings with SKETCHES, to issue revised drawings, to issue new drawings, and to delete drawings. When revised drawings are required to be sure to indicate the appropriate “Revision Date” in the REVISION BLOCK on each drawing. The revised areas shall be clouded and designated with the appropriate symbol.

NOTE: Do not make changes to drawings by word description that will cause bidders/Contractors to make changes in the design drawings.

2.2 To make revisions to the specifications by word descriptions to:

2.2.1 Revise words, numbers, sentences, or paragraphs.

2.2.2 Add or delete various sentences, paragraphs, pages, or complete sections.

3. NAVFAC REGULATIONS:

Require that amendments must be in the possession of each prospective bidder a minimum of ten (10) calendar days prior to the bid opening date. Failure to meet the deadline will result in bid postponement.

4. PREPARATION PROCESS:

When the need for an amendment arises, the A-E shall contact the Project Leader (PL) or an appropriate representative such that the Specification Specialist can provide a copy of the “Instructions for the Preparation of Amendments and Change Orders”. It would be helpful if there is a coordinated effort between the Specification Specialist and the A-E such that “First Submittal - Correct Amendment” principle can be achieved.

EXHIBIT 8-G

CHAPTER 9. COST ESTIMATES

9.1 GENERAL

This section establishes the requirements and provides the instructions for preparation of cost estimates. Project estimates based on plans and specifications shall be provided with each submission as required by the Statement of Architect-Engineer Services. For MILCON/BRAC projects, estimates must form the basis of the DD Form 1391 which is a part of the Engineering Documentation. The A-E objective is to develop a final cost estimate that will be within 10% of the lowest responsible bid considering all factors affecting costs including bidding climate. In the event that bids received on projects require clarification and analysis before an award can be made, the A-E shall provide that analysis at no additional cost to the government.

Additionally, the A-E shall provide an estimate for each Amendment and each Change Order Request (COR). The government Cost Engineers will provide the A-E with all cost guidance information necessary to develop a suitable project cost estimate. The government final cost estimates are to be marked by the A-E with "For Official Use Only". Access to or disclosure of information within the estimate is limited to those personnel whose official duties require knowledge of the estimate. The A-E shall consider all cost estimates to be confidential documents.

9.1.1 Purpose of Estimate

A properly prepared project cost estimate provides a check of plans and specifications for constructibility, coordination conflicts, discrepancies, omissions and cost control. They provide checks during design development to assure the project can be built with available funds. Estimates are also used by the government to establish and assure that sufficient money is requested to fund the project, develop historical data for future estimating and verification of contract bid prices.

9.1.2 Cost Engineering Estimate Format Guide

The Cost Engineering Format guide is a cost estimating document developed to make all A-E firms aware of the formats for estimates and other required documents that are considered acceptable for the development of 1391 plus, parametric cost estimate (PCE), 15%, 45%, 100%, and final construction cost estimates that are utilized throughout the Naval Facilities Engineering Command Engineering Field Divisions and Activities (EFDs/EFAs). Southwest Division's use of the estimates are for guidance only. If changes are warranted due to the nature of a project, contact the Senior Cost Engineer, Code 5717. **The government Senior Cost Engineer will provide the A-E with all cost guidance information necessary to develop a suitable project cost estimate at Scope meeting prior to the start of design.**

9.2 PROJECT ESTIMATE REQUIREMENTS

A detail project cost estimate submittal for all projects over \$100,000 shall be prepared and identified by at least the specification number and systems format in accordance with MIL-

HDBK-1010, Cost Engineering Policy and Procedures guide whether manually prepared or in the **Success** format. If additional information or clarification pertaining to estimates is required, a visit to the Cost Engineering Representative is highly recommended.

9.2.1 Estimating Format And Documentation

All cost estimates will be in the **Success** format except for the backup documentation for the Engineering Documentation which is a part of the Parametric Cost Estimate (PCE) and 1391 Plus Submittal for unique projects not readily adaptable to **Success**.

9.2.2 **Success**

The A-E will be required to run the estimate on his/her own computer equipment. Hard copy estimates will be required for each submittal. The **Success** program, data base and User's Guide are included on the Construction Criteria Base (CCB) compact disc. Contact Code 5717, Cost Engineer if CCB is not available. A copy of the NAVFAC **Success** configuration report file and manual with sample reports, will be made available to all A-E firms upon request. Include the following reports (menu selection) with each submittal.

- Input listing (sorted)
- Summary - Yes (choose "No" for summary %)
- Mark-up
- Modifier
- Detailed Estimate with Systems Sort
- Work Breakdown Structure (WBS)

Send a disk (3 ½ ", 90mm) containing the complete estimate with all submittals. Minimum computer equipment necessary for running estimates is:

a. Hardware

1. Microcomputer (486 processor or better recommended)
2. 640 K RAM memory
3. Standard microcomputer printer (laser printer suggested)
4. Hard disk (8 megabytes minimum)

b. Minimum Software Requirements

1. MS-PC DOS Version 3.0 (or greater)
2. A copy of COMMAND.COM (from the root directory) placed in the **Success** directory.)
3. The file CONFIG.SYS in the root directory with the following lines included:

FILE = 31
BUFFER = 30

These are minimum required to run **Success**.

4. System time and date must be accurate.

9.2.3 Detailed Estimate

Detailed Estimate means that all work required by each work breakdown structure (WBS) shall be completely estimated under the applicable WBS systems and subsystems in the **Success** format even though the project may include work at multiple facilities. For example, all concrete work and all interior electrical work in the detailed estimate shall be taken off by their respective work breakdown structures (WBS). One exception is items of work such as demolition, excavation, concrete, miscellaneous iron and other items incidental to the electrical or mechanical work which, following trade practice, are normally quoted and performed by those contractors.

9.2.4 Detailed Estimating Criteria

Provide the name of the person(s) and the firm with primary responsibility for preparation and checking on each estimate sheet. To facilitate comparison of estimated costs with the contractors' costs, follow construction trade practice. The first step in estimating cost is to decide what size and type of contractor is in the best position to be most competitive for the project under consideration. This decision will permit a determination of which items of work will be done by the prime contractor's for **Success** and which items are likely to be subcontracted. The appropriate markups for material and labor can then be developed. Use local costs including the appropriate material or equipment costs (so note in parentheses). This is mandatory and failure to comply may be reason for rejection of estimate. Include costs such as subsistence, transportation and the premium portion of overtime in General Requirements. Include incidental demolition, excavation, shoring, de-watering, concrete and miscellaneous metal for the mechanical and electrical sections in the mechanical and electrical estimates. The rule is to include everything and duplicate nothing. Provide a cross reference note in the applicable work breakdown structure section estimate. For example, the first item under CIP Concrete might be "see electrical estimate for duct bank encasement".

9.2.4.1 San Clemente Island And Alaska Projects

The rules under which the Contractor works are set forth in the specification. The costs for subsistence, travel, travel time, premium portion of overtime, and shipping are substantial and should be cost in General Requirements. Review any questions with the Cost Engineers, in order to understand and cost these items as would a contractor.

9.2.4.2 Units of Measure

Use standard units of measure common to the trade involved. The units used shall be those used in purchasing the principal material involved. Sufficiently describe the size, material, quality and type of items, or tasks to be performed in the item description to permit unit cost verification without constant reference to plans and specifications. Failure to do so may be grounds for rejection of the estimate. The accuracy of quantity take-offs should be carefully verified. Include a reasonable allowance for waste where applicable (concrete piping, etc.). Please include guidance for projects to be designed in SI units. See Para 5.2.3. attached.

9.2.4.3 Estimate Detail

Prepare all estimates, except the 15 percent submittal, in sufficient detail to permit verification of quantities and pricing. Do not use "Lump Sum", "Job" or similar expressions unless no alternative is possible or unless the cost is very minor. As an example of the detail required, do not lump footing concrete with column concrete since labor costs for concrete placement are most likely different. Cubic yard costs including formwork, rebars, concrete placing, curing and finish for each concrete element (footings, columns, etc.) may be acceptable for a 45 percent submittal but is not acceptable for a 100 percent or Final Estimate. Cost engineering judgement, however, does not require the breakout into finite detail of minor items which have little significance in the total job cost, but it does require an independent Government Estimate of construction costs in as great detail as if the Government were competing for the award of each proposed contract.

9.2.4.4 Unit Costs

After determining the type of contractor who will be in the best competitive position to successfully bid for the job, the various portions of the work can be allocated to one of the following categories of contractors.

- a. General Contractor and Sub-Contractors Unit Costs. General and Sub-Contractor Unit Costs for materials and equipment include delivery and applicable sales taxes less trade and payment discounts. Use a separate line for equipment to separate material and equipment costs for those operations that involve both costs and enter in the material column. Labor Unit Costs consist of a manhour total cost of Base Rate plus taxable Fringe Benefits and applicable Insurance Benefits for the appropriate labor classification divided by the productivity in the units of work involved for one hour of work. Include subsistence, premium

portion of overtime (when required), travel expenses and similar costs in the General Requirements, Division 1.

b. Mechanical/Electrical Unit Costs. The most comprehensive data on electrical and mechanical labor costs are published in the form of man-hours required to perform items of work. These are averages and may need adjustment. The detailed estimate by specification section is to follow the same format as previously described for the General Contractor unit costs, except that the mechanical/electrical sub-contractor's overhead and profit are added to each unit cost appropriate to the size, competitive climate and desirability of the job. Pay particular attention to trade discounts which vary but may approach a 50 percent reduction of list price for some items of mechanical and electrical materials and equipment. When the mechanical or electrical contractor is the prime contractor, do not add Overhead and Profit (OH&P) in unit prices.

9.2.5 Other Cost Factors.

9.2.5.1 General Requirements

General Requirements, is Division 1 of the estimate and is summarized as Division 1 of the General Summary. These costs should be carefully developed from the checklist shown below, using items applicable to the project. Note that the equipment covered in General Requirements is generally administrative/support equipment. Include Quality Control costs in General Requirements. There is a significant cost difference between jobs which require a QC Representative and support staff and the jobs which require a QC Representative only. (See specifications)

GENERAL REQUIREMENTS CHECKLIST

SUPERVISION

Superintendent
Civil Engineer
Layout
Timekeeper
Material Clerk
Non-working Foreman
Watchmen

CLEANUP

Periodic and Final Cleanup
Clean Floors
Clean Windows

INSURANCE

Surety Bond Watchmen
Public Liability Insurance

MISCELLANEOUS

Project Sign
Job Progress Photographs
Job Office Supplies
Travel Expense

Fire and Wind Damage
Equipment Floater Insurance

REPAIR

Repair Damaged New Work
Owner Call-Backs

QUALITY CONTROL (QC)

QC Representative

TRAVEL AND SUBSISTENCE

QC Assistant (part or full-time)
QC Clerical (part or full-time)
Material Testing Expenses
Professional Staff of Submittal Reviews
Certification Expenses
Specialty Inspectors

(Exclude Home Office Personnel)
Travel Expenses
Travel Time Pay
Subsistence
Site Differences

TEMPORARY FACILITIES

Mobilization Costs
Job Office
Storage Sheds
Tool Shed
Ladders and Ramps
Stairways
Job Toilets

EQUIPMENT

(General Contract administrative equipment and General Contractor equipment for general use for an extended period of time at the job site. Production equipment should be cost following the item of work requiring the equipment.)

TEMPORARY UTILITIES

Temporary Power Service
Temporary Power
Temporary Heat
Temporary Water
Temporary Water Service
Job Telephone

Pickup Trucks
Trucks
Forklift
Saw Rigs
Hoisting Towers
Cranes
Conveyors
Salamanders
Scaffolding
Wheel Barrows and Buggies
Power Tools
Picks, Shovels, Sledges, etc.
Miscellaneous Small Tools

TEMPORARY PROTECTION

Temporary Enclosures
Temporary Partitions
Barricades
Protect New Work
Protect Trees and Shrubs
Protect Existing Utilities
Protect Adjacent Property

9.2.5.2 Estimate Escalation

Add escalation to each design estimate. Escalate the project costs to the mid-point of the estimated construction period. Use the escalation line item for showing the mid-point escalation on the primary and sub contractors markup sheets in the **Success** formatted estimate.

9.2.5.3 Estimate Design Development Contingency

Add a percentage for contingency to allow for cost increases due to items of work which will become more clearly defined as the design develops. The added percentage shall be based on the judgment of the estimator. Show the percentage used on the primary and sub

contractors mark-up sheets under design contingencies. Delete Design Development Contingency from the 100% and Final Estimate.

9.2.5.4 Additive Bid Items

Additive bid items shall be prepared and presented in the estimate in the same manner as the base bid estimate. Normally, each Additive Bid Item should be within 2 to 10 percent of the base bid item with the total of all additive bid items not to exceed 25 percent of the base bid item. Limit additive bid items to four items unless otherwise authorized.

9.2.6 Submittal Guidance

The submittal requirement is the same for 45 percent, 100 percent and Final Estimate. Review comments will be provided at each submittal stage. A-E response to review comments at each submittal is mandatory. Remember all estimates will be submitted using the work breakdown structure (WBS) numbering system. Failure to do so will be cause "**for rejection.**"

9.2.6.1 Parametric Cost Estimate (PCE) Submittals, 1391 Plus & 15 Percent Estimates

Provide a primary and supporting facilities development sheet as back up for the budget estimate summary sheet, as indicated in the Cost Estimate Format Guide.

9.2.6.2 45 Percent Estimates

Prepare 45 percent estimates in as much detail as possible. Make sure that the scope of the project is clear. Fully develop the estimate summaries at the 45 percent stage even though the detailed work breakdown structure system by subsystem **Success** systems estimate may lack full detail. It is necessary to carefully evaluate escalation and design development contingencies discussed in previous paragraphs.

9.2.6.3 100 Percent Estimate

The 100 percent estimate shall be developed from completed drawings and specifications and shall be a firm and realistic estimate of the project cost based on a detailed and accurate quantity take-off extended with current unit costs. The summaries shall reflect costs by Bid Items as described in the bid documents and shall follow the approved or revised format furnished with the 45 percent review comments. As part of the 100 percent review comments, Cost Engineers will prepare a Cost Position Summary comparing it to the A-E's 100 percent estimate. Response to the summary and explanation to other review comments is mandatory and shall be provided as part of the Final Estimate Submittal.

9.2.6.4 Final Estimates

The final estimate should require only a backcheck of the 100 percent review comments if the project scope has not changed. If there is significant change in cost between the 100 percent and Final Submittal, verification will be required.

9.3 ENGINEERING DOCUMENTATION

See Chapter 3. If the project scope of work includes Engineering Documentation, the A-E is required to contact the Cost Engineer for detailed instructions on preparation. Examples of these items are shown in the Cost Engineering Estimate Format Guide.

9.4 AMENDMENT ESTIMATES

Amendment Estimates are issued to cover project changes after release of bid documents but prior to bid opening. The Amendment Estimate shall include only the items of work involved in each Amendment. Prepare a revised project Estimate General Summary to reflect the changes in the Estimate. The Amendment Estimate requirements for detail and format are identical to those of the Final Estimate.

9.5 CHANGE ORDER REQUEST ESTIMATES

Change Order Request (COR) Estimates are required when changes must be negotiated after the construction contract has been awarded. The format for this type of estimate is the same as that required of the Construction Contractor so as to assist the ROICC and to simplify negotiations. There are significant differences between development of COR Estimates and the Project Estimate previously discussed. Prepare separate estimates of direct costs for deductive and additive costs. Prepare a separate estimate for the Prime Construction Contractor's work and for each sub-contractor involved in the changed work. If necessary, contact the cognizant ROICC for information on the division of work between the general contractor and subcontractors. Examples of COR estimates format can be found in the Cost Engineering Estimate Format Guide available from the Cost Engineers. The A-E of record will only be required to complete the back sheet portion which is the unburdened cost. In-house estimates by the cost engineers will follow the same guidance.

9.6. BID ANALYSIS

Provide an analysis of the low bid when the low bidder is greater than ± 10 percent from the Final Government Estimate or when there is substantial variance with the other bidders and viability of the low bid is questionable. This involves the comparison of estimates with the low bidder's to the extent that areas of differences can be identified and evaluated for responsiveness to project requirements. The confidentiality of the Government Estimate shall be maintained and quantitative elements shall be divulged only as is necessary to obtain information for analysis and conclusions.

9.7 8(a) CONTRACTS

Since 8(a) projects are negotiated directly with the Contractor, the Government estimate should reflect that work for which funds are available and no more. There will be no Additive Bid Items allowed in 8(a) projects. There is only a Base Bid Item. The detailed estimate will be formatted in the same manner as estimates prepared for regular MCON project as described herein before, except that the A-E will prepare a detailed estimate package with line item description and unit of measure only to be given to the 8(a) contractor for his use in presenting his proposal. Another variance from MCON prepared estimates is that on 8(a) projects the A-E will designate those items of work assumed to be performed by the prime contractor and those to be done by sub-contractors. Use the notation (P) or (S) on those items done by each. The A-E will also fill in those blocks on the detailed estimate sheets designated by a check mark (✓). The 8(a) contractor will complete other blocks.

9.8 OPERATION AND MAINTENANCE (O&M) PROJECTS

These types of projects involve any combination of Construction, Repair, Maintenance, and Equipment Installation and are funded from local appropriations. For funding control, it may sometimes be required that line items in the cost estimates be designated with a "C", "R", "M", and "E" to identify and segregate the types of work involved. Where this is a requirement of the Statement of A-E Services, consult with the Cost Engineers for guidance.

NOTES

CHAPTER 10. A-E INVOICING PROCEDURES

10.1 GENERAL

Payment will only be made on executed contracts and executed modifications. Progress payments are due and payable whenever a significant amount of work has been accomplished and upon receipt from the A-E of the completed forms:

- a. Contract Performance Statement, NAVFAC 10-7300/31, (See Exhibit 10-A)
- b. Contractor's Invoice, NAVFAC 7300/30, (See Exhibit 10-B)
- c. A-E Travel Claim Voucher, SOUTHWESTNAVFACENCOM 4650/17 (See Exhibit 10-C)

Note: With final invoices include Contractor's Release, NAVFAC 4330/7, (See Exhibit 10-D)

10.2 INVOICE SUBMISSIONS

Submit originals only.

10.2.1 Mailing Instructions

For Procedure I: mail and address all invoices to the attention of the contracting officer, and plainly mark the lower left-hand corner of the front of the envelope:

[Insert name of the Command's Address]
INVOICE ENCLOSED Project P-____ or R____ - ____
ATTENTION: Contracting Officer (refer to the contract document for the appropriate code)

For Procedure II: contracts, submit to the ROIC at contracting activity. Plainly mark the lower left-hand corner of the front of the envelope: "INVOICE ENCLOSED".

10.3 INVOICING FREQUENCY

Normally, partial payments are made at the 15%, 45%, 100% and Final stages of the design. Alternatively, partial payments will be made upon request by the A-E, whenever a significant amount of the contracted services have been accomplished, such as site investigations. However, no more than one (1) invoice per month per contract or delivery order will be accepted for payment. Payments will be made on the basis of the overall percentage of completion. Include completed forms, Exhibits 10 -A and 10-B, at each invoicing.

10.3.1 Travel

Include a completed A-E Travel Claim Voucher, Exhibit 10-C, for each individual when invoicing for travel.

10.3.2 Final Invoice

Include executed Contractor's Release, Exhibit 10-D. Final payment will be made after:

- a. The Final Submittal has been reviewed and accepted;
- b. The A-E has submitted a properly executed contractor's release; and
- c. The A-E has returned all materials borrowed from the government.

10.4 CONTRACT PERFORMANCE STATEMENT, NAVFAC 10-7300/31 (EXHIBIT 10-A)

Exhibit 10-A shows invoicing format applicable when the A-E contract involves the design of one or more facilities. Include only items of the original contract and the change orders thereto. The award of services included as contract options will be by change order. If Post Construction Award Support is included as an option to the A -E Contract, a change order for these services will be issued after award of the construction contract. Item by item guidance on how to complete the Contract Performance Statement, Exhibit 10-A follows:

10.4.1 Location

The title and location of work as shown in the contract document.

10.4.2 Contract

A-E contract number.

10.4.3 Sheet Numbers

Number sheets consecutively.

10.4.4 Period Ending Date

Actual closing date of work for which invoice is presented. The period ending date must agree with the date on which the work was actually completed; e.g., the date on which submittals were actually made to Command.

10.4.5 Cost Category

Column (1). Leave blank.

10.4.6 Description Column (2)

Shall agree with descriptions of work authorized under the contract. Each portion of the A-E work shall be itemized as shown. Include any travel and per diem allowance contained in the contract in the itemized listing. If the contract includes Post Construction Award Support, provide separate descriptions for Construction Contract Support Services, Field Consultation During Construction and Value Engineering Evaluation, Title II Inspection, as applicable.

10.4.7 Estimated Cost - Column (3)

The estimated cost shall agree with the contract price and any subsequently approved modifications, including travel allowance. Enter modifications separately. Do not include work not covered by an executed contract document. The total of this column shall be the total value of the contract to date. For final invoicing involving reimbursable items, column (3) should be reduced to show actual costs and total if the A-E claims less than the amount authorized.

10.4.8 Percent Complete - Column (4)

The total of this column is the percentage of physical completion of the contract requirements as estimated by the A-E. Where this quotient involves a fractional percentage, the figure should be rounded. For final invoicing involving reimbursable items, column (4) should show 100 percent.

10.4.9 Value - Column (5)

The value of the completed work is the estimated cost of each item as shown in column (3) multiplied by the percent completed as shown in column (4). In no event will an invoice be processed for payment where the total indicated for column (5) is in excess of the total indicated for column (3) multiplied by the total percentage indicated for column (4). For final invoicing, include the actual costs for reimbursable items.

10.5 CONTRACTOR'S INVOICE, NAVFAC 7300/30, (EXHIBIT 10-B)

Include the name and code of the PL and the project identifiers as shown on Exhibit 10-B.

10.5.1 Invoice Date

Date of submission of invoices. This cannot precede "Period Ending" date shown on accompanying Contract Performance Statement, and shall not precede date of award of contract nor date of previous invoice.

10.5.2 Invoice Number

Insert the number of the invoice starting with "1" and continuing in sequence for subsequent invoices. The last invoice under the contract shall be labeled "Final".

10.5.3 From

Shall be the firm name, Point of Contact (P.O.C) and complete address as shown in the contract document.

10.5.4 Contract

Insert the contract number as shown on the contract document.

10.5.5 Station

The location of work as shown in the contract document.

10.5.6 Total Value Of Contract Through Modification

Insert the numerical designation of the last executed modification. The amount of the total value of contract shall agree with the total shown on column (3) of the Contract Performance Statement, including travel and per diem allowance. On the final invoice, this figure should be reduced to reflect actual costs for reimbursable items such as Travel, Field Consultation and Value Engineering Evaluation if the A -E claims less than the reimbursable amounts authorized.

10.5.7 Percentage Of Performance Complete

Divide column 5, Exhibit 10-A, (total) by line A, Exhibit 10-B.

10.5.8 Value Of Completed Performance

The value of completed performance shall agree with the total of column (5) of Exhibit 10-A.

10.5.9 Less: Total Of Prior Invoices

Insert the total of previous invoices and not the actual amount received by the A -E.

10.5.10 Amount Of This Invoice

Subtract line D from line C.

10.5.11 Signature

A principal of the firm shall sign the invoice. Indicate title of the person's position in the firm. Leave the first endorsement section blank.

10.6 NON-ACCEPTANCE OF A-E INVOICE

Improperly prepared invoices that do not meet the requirements of this A -E Guide will be returned to the A-E within 7 days of receipt, stamped NOT ACCEPTED. When you re-submit a properly prepared invoice, the date on it must be the date re -submitted and not the original date of the NOT ACCEPTED invoice. The invoice number will remain the same.

10.7 DISALLOWANCE ON INVOICED AMOUNT

Line item(s) or percentages of line items will be disallowed when the supporting documentation is absent or incomplete or when the PL disagrees with the A-E's estimate of the quantity of work performed.

NOTES

LOCATION: AIRFIELD PAVEMENT & ROAD REPAIR, NAVSTA SAN DIEGO

TO BE COMPLETED BY CONTRACTOR					FOR ROICC USE ONLY			
COST CATE- GORY	DESCRIPTION	ESTIMATED COST	% COM- PLETE	VALUE	%	CONSTRUCTION IN PLACE		
						VALUE	PRIOR REPORT	THIS PERIOD
(1)	(2)	(3)	(4)	(5)	(6)	(7)	(8)	(9)
	<u>A-E SERVICES</u>							
	<u>AIRFIELD PAVT. P-048</u>							
	Sub-Surface							
	Investigation	\$ 5,000.00	100	\$ 5,000.00				
	Survey	\$ 4,000.00	100	\$ 4,000.00				
	Field Investigation	\$ 1,000.00	80	\$ 800.00				
	Design	\$25,000.00	20	\$ 5,000.00				
	Travel	\$ 4,500.00	-0-	\$ -0-				
	Modification P-001	<u>\$ 6,700.00</u>	<u>30</u>	<u>\$ 2,010.00</u>				
	Sub-Total	\$46,200.00	37	\$16,810.00				
	<u>ROAD REPAIR - R7-60</u>							
	Sub-Surface							
	Investigation	\$ 3,000.00	100	\$ 3,000.00				
	Survey	\$ 2,000.00	80	\$ 1,600.00				
	Field Investigation	\$ 1,000.00	100	\$ 1,000.00				
	Design	\$20,000.00	20	\$ 4,000.00				
	Travel	\$ 1,000.00	-0-	\$ -0-				
	Modification P-002	<u>\$ 4,500.00</u>	<u>10</u>	<u>\$ 450.00</u>				
	Sub-Total	\$31,500.00	32	\$10,050.00				
TOTAL		\$77,700.00	34	\$26,860.00				
UNDISTRIBUTED CHARGES MATERIAL								
OTHER								
GRAND TOTALS								

REMARKS

 ROICC Name and Rank

LOCATION: AIRFIELD PAVEMENT & ROAD REPAIR, NAVSTA SAN DIEGO

TO BE COMPLETED BY CONTRACTOR					FOR ROICC USE ONLY			
COST CATE- GORY	DESCRIPTION	ESTIMATED COST	% COM- PLETE	VALUE	%	CONSTRUCTION IN PLACE		
						VALUE	PRIOR REPORT	THIS PERIOD
(1)	(2)	(3)	(4)	(5)	(6)	(7)	(8)	(9)
	<u>POST CONSTRUCTION</u> <u>AWARD SUPPORT</u> <u>AIRFIELD PAVT. P-048</u> Modification P003 Construction Contract Support Services Field Consultation During Construction 2 days @ \$312.50 Value Engineering Evaluation 20 Hrs. @ \$32.00 Sub-Total	\$ 2,500.00 \$ 625.00 \$46,200.00 <u>\$ 620.00</u> \$\$ 3,765	10 40 37 <u>50</u>	\$ 250.00 \$ 250.00 \$16,810.00 <u>\$ 320.00</u> \$ 820.00				
TOTALS								
UNDISTRIBUTED CHARGES-MATERIAL								
OTHER								
GRAND TOTALS								

REMARKS

 ROICC Name and Rank

LOCATION: AIRFIELD PAVEMENT & ROAD REPAIR, NAVSTA SAN DIEGO

TO BE COMPLETED BY CONTRACTOR					FOR ROICC USE ONLY			
COST CATE- GORY	DESCRIPTION	ESTIMATED COST	% COM- PLETE	VALUE	%	CONSTRUCTION IN PLACE		
						VALUE	PRIOR REPORT	THIS PERIOD
(1)	(2)	(3)	(4)	(5)	(6)	(7)	(8)	(9)
	<u>POST CONSTRUCTION AWARD SUPPORT</u>							
	Road Repair Modification P-004 Construction Contract Support Services	\$ 2,000.00	10	\$ 200.00				
	Field Consultation During Construction 2 days @ \$390.00	\$ 780.00		\$ 650.00				
	Value Engineering Evaluation 10 hrs. @ \$30.00	\$ 300.00		\$ 150.00				
	TITLE II INSPECTION	<u>\$100,000.00</u>		<u>\$ 10,000.00</u>				
	Sub-Total	\$103,080.00		\$ 11,000.00				
TOTALS		\$184,545.00	21	\$ 38,680.00				
UNDISTRIBUTED CHARGES MATERIALS								
OTHER								
GRAND TOTALS								

REMARKS

 ROICC Name Rank

NAVAL FACILITIES ENGINEERING COMMAND A - E CONTRACTOR'S INVOICE

CONTRACT SPECIALIST: _____ INVOICE DATE: _____
 PROJECT NO. D. O. # _____ INVOICE NUMBER: _____
 PROJECT TITLE: _____

FROM:

TO: COMMAND, CODE 0211

1. Below is a Statement of Performance under Contract N68711 _____
 at (Station) _____

The enclosure provides breakdown of this statement of performance.

A. Total value of contract through change _____		\$ _____
B. Percentage of performance complete _____		_____ %
C. Value of completed performance _____		\$ _____
D. Less: Total of prior invoice _____		\$ _____
E. Amount of this invoice _____		\$ _____

Signature and Title: _____

From: _____ Date: _____
 To: _____

1. Payment is recommended as follows:

A. Amount of work completed to _____		\$ _____
B. Less:		
Retention: \$ _____		
Other Deductions: \$ _____		
C. Subtotal: _____		\$ _____
D. Less Previous payments _____		\$ _____
E. Recommended amount for _____ payment		\$ _____

RESPONSIBLE CERTIFYING ACTIVITY UIC _____
 INVOICE RECEIPT DATE _____
 MATERIAL/SERVICES RECEIPT DATE _____
 MATERIAL/SERVICES ACCEPTANCE DATE _____
 DATE FORWARDED TO PAYING ACTIVITY _____

I CERTIFY THIS AMOUNT IS CORRECT AND PAYMENT IS RECOMMENDED:

_____ SIGNATURE/TITLE	_____ DATE
--------------------------	---------------

<u>ACRN</u>	<u>APPN/SUBHEAD</u>	<u>OC</u>	<u>BCN</u>	<u>SA</u>	<u>AAA</u>	<u>TT</u>	<u>PAA</u>	<u>COST CODE</u>	<u>AMOUNT</u>
-------------	---------------------	-----------	------------	-----------	------------	-----------	------------	------------------	---------------

A-E TRAVEL CLAIM VOUCHER

NAME

FIRM

PLACE OF TRIP

PURPOSE OF TRIP

AUTHORIZED BY

DATE

ITINERARY			
DATE	LOCAL TIME (24 Hour Clock)	(Home, Office, Base, Activity, City and State, City and Country etc)	MODE OF TRAVEL
19			
	DEP		
	ARR		
	DEP		
	ARR		
	DEP		
	ARR		
	DEP		
	ARR		
	DEP		
	ARR		
	DEP		
	ARR		
	DEP		
	ARR		

REIMBURSABLE EXPENSES

CAR RENTAL _____ \$

CAR PARKING _____ \$

PRIVATE CAR MILEAGE(.29/MILE)___ \$ _____ I CERTIFY THAT AMOUNTS ARE ACTUAL AND NECESSARY

BRIDGE, ROAD, FERRY TOLLS _____ \$ _____ EXPENSES INCURRED IN PERFORMANCE OF OFFICIAL

GASOLINE _____ \$ _____ TRAVEL FOR WHICH I HAVE NOT BEEN REIMBURSED:

TAXI _____ \$ _____

AIR FARE _____ \$ _____

(SIGNATURE)

DATE

REQUIRED ATTACHMENTS: A. RECEIPTS FROM CARRIERS, COPIES OF TICKETS, OR REQUIRED CERTIFICATIONS IF COST OF TRANSPORTATION IS CLAIMED.

B. RECEIPTS FOR LODGINGS AND ANY ITEM OF EXPENSE CLAIMED IN EXCESS OF \$25.00.

C. ITEMIZATION OF ACTUAL EXPENSES ON A DAILY BASIS WHEN CLAIM FOR REIMBURSEMENT INCLUDES TRAVEL ON AN ACTUAL EXPENSE BASIS.

INFORMATION REQUIRED BY THE PRIVACY ACT OF 1974. AUTHORITY: 5 U.S.C. 5701-5742.37 U.S.C. 404-427, AND E.O. 9397 PRINCIPLE PURPOSE: USED FOR REVIEWING, APPROVING, ACCOUNTING AND DISBURSING FOR OFFICIAL TRAVEL.

ROUTINE USES: TO SUBSTANTIATE CLAIMS FOR REIMBURSEMENT FOR OFFICIAL TRAVEL.

DISCLOSURE: VOLUNTARY. FAILURE TO FURNISH INFORMATION REQUESTED MAY RESULT IN TOTAL OR PARTIAL DENIAL OF CLAIM.

CONTRACTOR'S RELEASE UNDER CONTRACT

KNOW ALL MEN BY THESE PRESENTS: In consideration of the premise and the sum of

_____ (\$ _____)

lawful money of the United States of America (hereinafter called the "Government")

_____ (\$ _____)

of which has already been paid and

_____ (\$ _____) of which is to be paid

by the Government under the above-mentioned contract, the undersigned Contractor does, and by the receipt of said sum shall,

for itself, its successors and assigns, remise, release and forever discharge the Government, its officers, agents, and

employees, of and from all liabilities, obligations and claims whatsoever in law and in equity under or arising out of said

contract.

IN WITNESS WHEREOF, this release has been executed this _____ day of _____ 19

WITNESS:
(Contractor)

_____ BY:

_____ TITLE:

CERTIFICATE

I, _____, certify that I am the _____ secretary

of the corporation named as contractor in the foregoing release; that

who signed said release on behalf of the Contractor was then _____ of said corporation;

that said release was duly signed for and in behalf of said corporation by authority of its governing body and is within the

scope of its corporate powers.

(Corporate Seal)

ATTACHMENT A

CALCULATION REQUIREMENTS

1. GENERAL

Furnish in separate bound volumes by disciplines, designated as "Calculations" all supporting data, rationale (system and equipment selection, engineering considerations and life cycle cost) and calculations. When the 45% submittal is not required, calculations normally required to be submitted with the 45% shall be submitted with the 100% submittal.

1.1 45% SUBMITTAL

1.1.1 Civil

Provide calculations to support the design for the following:

- a. The quantity of water required and the sizes, material and class of all pipes, reservoirs and pumps for all water systems. Also provide typical pump and system curves.
- b. The quantity of sewage and the sizes, material and type of all sewer lines for all sanitary sewer systems. Also provide typical pump and system curves.
- c. To verify the design flow and sizing of all Sewage Treatment System units.
- d. The asphalt and paving sections.
- e. Storm drainage facilities.
- f. To indicate if the site has a balanced cut/fill or the quantity of borrow/ disposal.
- g. Retaining wall design to comply with the latest edition of UBC.

1.1.2 Structural

Provide sufficient structural calculations to verify the framing system, and all major structural elements for all loads including wind and seismic.

1.1.3 Mechanical

Provide calculations for the following:

- a. Building or room heat gain and loss.

- b. Pressure drops for pump and compressor selection.
- c. Duct, equipment and other external losses for fan selection.
- d. Water capacity of pipe and equipment and pressures used for system design and for expansion tank selection.
- e. Expansion and contraction of piping with stresses at loops and anchor points.
- f. Cv value selection for all control valves.
- g. For direct expansion refrigeration systems, provide information for pressure drops and velocities of gas and liquid (including velocity to return oil for gas and suction risers), at zero degrees F.
- h. Water heaters - capacity and make up requirements.
- i. Heat exchanger - temperature, flow, capacity and heat rejection rate.
- j. Fluid velocity in pipes and ducts.

1.1.4 Electrical

Provide calculations for the following:

- a. Preliminary connected and demand load tabulations.
- b. Lighting calculations showing design and calculated foot-candles to justify quantity, type, and layout of fixtures.

1.1.5 Fire Protection

Provide calculations for the following:

- a. Total sprinkler system demand based upon discharge density, area of sprinkler operation and outside hose allowances.
- b. Fire pump size and pressure calculation.
- c. Foam application rate.
- d. Rate of application of CO₂ and any other approved clean agent.
- e. Smoke control system pressure difference, airflow and response time.

- f. Fire flows and pressures.

1.2 100% SUBMITTAL

1.2.1 Civil

Provide calculations to verify:

- a. Quantity of storm flow (use MIL-HDBK-1005/2 and 1005/3), velocities, sizes, material, class and "D" load design of all storm sewers and culverts, outlets, erosion controls, and sizes of drop inlets for Storm Sewer Systems and surface drainage.

1.2.2 Irrigation System

Provide calculations for the following:

- a. Calculations for:

1. Valve at highest elevation.
2. Valve at lowest elevation.
3. Valve with highest GPM (L/M) and GPH (M³/H).
4. Valve with lowest GPM (L/M) and GPH (M³/H).

- b. Calculation sheet indicating valve sequence number, total GPM/GPH, elevation of valve, water meter and highest irrigation head or emitter, total friction loss through all irrigation equipment and piping, operating PSI (kPa) of irrigation head or emitter and residual PSI, or kPa.

1.2.3 Structural

Provide refinement of 45 percent calculations, i.e., detailed calculations to verify adequacy of design and selection of structural system. Calculations shall include but are not limited to:

- a. Vertical and lateral analysis.
- b. Anchorage for Mechanical, Electrical and Non-structural elements.

1.2.4 Mechanical

Provide refinement of 45 percent calculations, i.e., complete detailed calculations to verify adequacy of design and selection of equipment, source connections, and flow balance. Calculations shall include but not limited to:

- a. Room by room load calculations.
- b. Final steam, hot water, chilled water, gas, oil, etc., distribution and flow balance.
- c. Update flow diagram to reflect final loads, equipment capacity and pressure requirements.

1.2.5 Electrical

Provide calculations to verify adequacy of design and selection of equipment, conductors, and protective devices. Include as a minimum the following:

- a. Load tabulation of connected and demand loads.
- b. Voltage drop calculations for conductors.
- c. Voltage drop calculations for starting large motors.
- d. Short circuit calculations.
- e. Lighting calculations.
- f. Coordinated time-current characteristic curves of protective devices. Final device settings and time-current characteristic curves shall be provided during construction when exact devices are known.
- g. Tension and sag calculations for pole line conductors, messengers, and guys.

1.2.6 Fire Protection

Update 45% calculations to verify adequacy and accuracy of the system. Complete hydraulic calculation of sprinkler and foam water system to verify adequacy of available water supply.

ATTACHMENT B

COMPUTER AIDED DESIGN AND DRAFTING STANDARDS

1. GENERAL

COMPUTER AIDED DESIGN AND DRAFTING STANDARDS

1.1 Project Design And Construction Documents

Project design and Construction Documents shall be produced using Computer Aided Design and Drafting (CADD) Technology. Compatibility with Southwest Division hardware and software is required to permit effective review, use and eventual modification of the drawings by the government. The following specific requirements are provided to ensure that the deliverable items furnished under the design contract are capable of being fully utilized by Southwest Division and by the Station/Activity. A-Es shall take all reasonable measures to make sure their CADD work product can be utilized effectively and efficiently by Southwest Division using its existing Microstation 95 based CADD systems running on the Microsoft Windows NT version 4.0 operating system.

2. DEFINITIONS

2.1 Definitions That Apply To References And Uses Included In These Standards

- a. MS-DOS 5.0 or higher (MicroSoft Disk Operating System), Windows 3.x, Windows 95 or Windows NT 4.0 a registered trademark: Refers to a disk operating system that is fully compatible with AutoCAD Release 13 or Microstation 95 or lower version compatible with Microstation 95.
- b. AutoCAD Release 13 and Microstation version 95: Computer Aided Design and Drafting (CADD) software programs, registered and trademarked by Autodesk, Inc. and Bentley Corporation, respectively.
- c. Drawing: A plotted output hard copy representation of drawn design data prepared on vellum or other suitable reproducible material. The plotted output must be accomplished by electromechanical means, such as a pen plotter, electrostatic plotter, etc. Hand drafted changes and/or additions to plotted drawings after final plot will not be acceptable. Final plots shall match "*.DWG" or "*.DGN" file on magnetic media completely. The quality, size, configuration, and other physical attributes of final plotted drawings shall be as described in the contract.
- d. Menu Modifications: Any and all modifications to default menu configurations (supplied by Autodesk, Inc., or Bentley Corporation, with the originally issued program package), which are, or were, created by the A-E through the use of text files and text editors to facilitate the production of the Project Documents.

- e. LISP Routines: Any and all new LISP or AutoLISP routines which are, or were, created by the A-E through the use of text files and text editors to facilitate the production of the Project Documents. For purposes of this document, the terms "LISP" and "AutoLISP" shall be considered to be synonymous.
- f. Data Base Files: Any and all deliverable information supplied by the A-E which may contain either graphic data, nongraphic data, or a combination of both, stored upon, and retrievable from, digital media in either ASCII text files or "*.DWG/DGN" files compatible with AutoCAD Release 13 or Microstation 95. Specific files included shall contain all files and data necessary to facilitate reading, loading, copying, editing, and plotting all of the various data files.
- g. Digital Media: ISO 9660 compliant Compact Disk (CD-ROM).
- h. Hard Copy: A printed or plotted copy (photo-reproducible) in "letter" or "drawing" format.
- i. ASCII (American Standard Code for Information Interchange): Text file format resulting from the utilization of a word processing program. The word processing program shall be compatible with Microsoft Word, Version 6.0.
- j. Electronic Bid Solicitation (EBS): An electronic acquisition methodology standardized by the Tri-Service CADD/GIS Technology Center. EBS consists of the same Contract Forms, Clauses & Conditions and Drawings & Specifications used for normal acquisition, i.e., hard copy paper documents, in electronic form distributed on compact disk (CD-ROM) and/or over the internet. In order to facilitate Southwest Division's use of EBS methodology, electronic submittal deliverables will be required to be in Adobe Acrobat version 3.0 Portable Document Format (PDF) and Dataware Electronics SourceView SVD format. More information regarding these softwares can be obtained as follows:
Adobe Systems, Inc.: 345 Park Avenue, San Jose, CA 95110-2704
phone: (800) 879-3219 website: <http://www.adobe.com/acrobat>
Dataware Electronics, Inc.: P.O. Box 507 Everett, WA 98206
phone: (206) 258-3032 website: <http://www.whidbey.net/~dataware>

3. DELIVERABLES

3.1 Computer Files

Computer files created for Southwest Division projects through the use of CADD are deliverable items to be furnished on ISO 9660 compliant CD-ROM. At the A-E's option, optical WORM disks or other high capacity media may be acceptable if compatibility is verified prior to submittal. All deliverable items are the property of the government. Any use of these deliverables by the government will not result in any further obligations to the A-E. The Government, for itself and such others as it deems appropriate, will have

unlimited rights under this contract to all information and materials furnished to the Government and documentation thereof, reports and listings, and all other items pertaining to the work and services pursuant to this agreement including any copy right. Unlimited rights under this contract are rights to use, duplicate, or disclose data, and information, in whole or part in any manner and for any purpose whatsoever without compensation to or approval from the contractor. The Government will at all reasonable time have the right to inspect the work and will have access to and the right to make copies of all the above-mentioned items. All digital files and data, and other items generated under this contract, shall become the property of the Government. By reference, the following DFAR clauses are included in this contract as a part of the requirements herein:

- a. DFAR 252.227-7013, "Rights in Technical Data and Chapter Software."
- b. DFAR 252.227-7028, "Requirements for Technical Data Representation."
- c. DFAR 252.227-2037, "Validation of Restrictive Markings on Technical Data."

3.1.1 Required Files

Required files include, but are not limited to, the following:

- a. Drawings: All hard copy drawings produced for the purpose of designing and/or drafting the Project in compliance with the requirements of the A-E Contract, the A-E Guide and other referenced instructions, directives, design manuals, etc.
- b. Electronic Files: All files shall be uncompressed, native format and compatible with and readable (without modification) by AutoCAD, version 13 or Microstation 95. Required files include, but are not limited to, the following files and will be placed in a directory structure separating each design discipline:
 - (1) Project Drawings; in three formats - uncompressed native file format (DWG or DGN), plot files using an HPGL/2 plotter driver (PLT) and CALS Group 4, Type 1 raster format (CAL). To facilitate Electronic Bid Solicitation by Southwest Division, CALS files will be indexed using Dataware Electronics SVAuthor software yielding an SVD format file for viewing by Dataware Electronics public domain SVReader software.
 - (2) All Drawing library symbols, blocks, attributes, script files, hatch and/or fill patterns, text fonts and/or styles, etc., utilized during the preparation of the Project Drawings;
 - (3) All menu modifications, LISP programs and routines, and other custom commands utilized in the development of the Project Drawings and required to facilitate evaluation and/or editing of the Project files.

(4) SpecsIntact SGML Specifications in both uncompressed native file format and Adobe Acrobat version 3.0 Portable Document Format (PDF). To facilitate Electronic Bid Solicitation by Southwest Division, PDF Specifications will be produced utilizing Adobe Acrobat Exchange version 3.0. PDF Specification will be "bookmarked" to the first page of each division & section and the table of contents will be "linked" to each division & sections first page. A PDF file containing the entire specification and separate PDF files for each of the 16 divisions is required.

(5) Cost Estimates; in both uncompressed native file format and Adobe Acrobat version 3.0 Portable Document Format (PDF).

(6) Calculations; if handwritten, calculations will be scanned and converted to Adobe Acrobat version 3.0 Portable Document Format (PDF).

(7) Reports; in both uncompressed native Microsoft Word 6.0 file format and Adobe Acrobat version 3.0 Portable Document Format (PDF).

(8) Design review comments in both uncompressed native Microsoft Word 6.0 file format and Adobe Acrobat version 3.0 Portable Document Format (PDF).

(9) To facilitate Electronic Bid Solicitation by Southwest Division, appropriate versions of public domain Adobe Acrobat Reader and Sourceview Reader software in Windows 16 bit and 32 bit versions in separate directories.

4. DOCUMENTATION DELIVERY

4.1 Required Documentation

Required documentation shall be delivered in hard copy form, 8 ½" x 11" paper (210mm x 297mm) and on digital media utilizing ASCII format and shall include, but not be limited to, the following:

- a. Indexed Listing of all data files included in the Project;
- b. Cross Listing of all file names and corresponding Drawing names;
- c. Indexed Listing of all data files required for each Drawing, including, but not limited to:
 - (1) Symbols and blocks with scale factor and attribute data;
 - (2) Hatch and fill patterns, text fonts, etc.

- d. Comprehensive Listing of all menu modifications, LISP routines, and/or customized commands required to properly load, edit and plot each Drawing;
- e. Complete plotting instructions.

5. COMPOSITION OF FILES

5.1 Project Drawing Characteristics

Project Drawings, drawing files, and other graphic intelligence files shall be created in accordance with the Tri-Service A/E/C CADD Standards release 1.4, as published by the Tri-Service CADD/GIS Technology Center. For more information on the Tri-Service A/E/C CADD Standards and/or a copy on CD-ROM, contact:

Tri-Service CADD/GIS Technology Center
Attn. CEWES-IM-DA/Spangler
3909 Halls Ferry Road.
Vicksburg, MS 39180-6199
Phone: 1-800-522-6937 x6783
e-mail: spangls@ex1.wes.army.mil
Home Page: <http://mr2.wes.army.mil>

Station/Activity preference, where same exists, regarding layer/level, line weight and plotting information, etc. shall take precedence over the Tri-Service A/E/C CADD Standards.

- a. Drawings: Shall be modular in construction and content with respect to the various text, symbols, blocks, attributes and individual drawing entities. The A-E shall institute a quality control program to insure maximum modularity.
- b. Symbols and Blocks: Consisting of various groupings of entities, as required, and showing functional definitions or "blocks" of each drawing. (For example, for a Mechanical Drawing defining a chilled water piping system, a block may consist of predefined entity groupings representing pumps and valves.) Symbols and blocks utilized to produce a Drawing shall be furnished separately as parts of a symbols library and shall identify all individual entities utilized to construct the symbol or block, in order to facilitate future editing and/or reconstruction.

6. PROJECT SCHEDULE

6.1 Project Design Schedule And Phase.

The Project schedule shall be separated into two distinct parts, subject to variations relating to the A-E Contract and to the A-E Scope of Work.

a. Design Phase:

(1) 45% Submittal: Shall include all Drawings which are a part of the 45% submittal package and shall include all Deliverables and Documentation described in Items 3 and 4 above.

(2) 100% Submittal: Shall include all Drawings which are a part of the 100% submittal package and shall include all Deliverables and Documentation described in Items 3 and 4 above, including all corrections required as a result of Government Review.

(3) Final Submittal: Shall include all Drawings which are a part of the Final submittal and shall include all Deliverables and Documentation described in Items 3 and 4 above, including all corrections required as a result of Government Review.

b. Construction Contract Support Services Phase: The A-E shall update all CADD drawing and database files to reflect project as-built conditions as indicated by the record documents kept by the construction contractor at the job site. Upon completion of the construction project, hard-copy as-built drawings and all updated computer files shall be delivered to the government.

ATTACHMENT C

CODE CRITERIA SEARCH

ALL UNITS OF MEASURE SHALL BE IN SI UNITS.

Project Title:

Location:

A-E Contract No: _____ Date:

Name of the Firm:

Point of Contact: _____ Tel:

Project Leader: _____ Tel:

APPLICABLE CODES, CRITERIA AND DESIGN POLICY:

- o MIL-HDBK-1008B: Dated 15 Jan 1995
- o NATIONAL FIRE CODES (N.F.P.A) : Latest Edition
- o UNIFORM BUILDING CODE: Latest Edition
- o NAVFAC DESIGN POLICY DPL NO.

(MIL-HDBK-1008B and Design Policy Supersedes NFPA & UBC Requirements where addressed)

**1. OCCUPANCY:
(MIL-HDBK-1008B AND UBC Chapter 3,5 & 6)**

1.1 Use: _____

1.2 Occupancy: _____ (Table 3-A)

1.3 Required Separation (from property lines): _____ (Table 5-A)

- 1.4 Required Separation from bldg(s) with mixed occupancy: _____ (Table 3-B)
- 1.5 Construction Type: _____ (Table 5-B)
- 1.6 Allowable Floor Area: _____ SF/m² (Sec 504, Table 5-B)
- 1.7 Allowable Building Height (In stories or FT (m)): _____ (Sec 506, Table 5-B)
- 1.8 Allowable Area Increases(Sec. 505)
- 1.8.1 Separation on two sides: _____ % x _____ FT/m = _____ SF/m²
- 1.8.2 Separation on three sides: _____ % x _____ FT/m = _____ SF/m²
- 1.8.3 Separation on all sides: _____ % x _____ FT/m = _____ SF/m²
- 1.8.4 Unlimited Areas: ____ Yes, ____ No
- 1.8.5 Automatic Sprinkler System: ____ Yes, ____ No, ____ Exception Applied
 _____ X _____ SF/m² = _____ SF/m² Increase
- 1.10 Total Allowable Area: _____ GSF/Gm²
- 1.11 Building Height Increases: _____ stories or FT/m (Sec. 506)
- 1.12 Total Allowable Stories: _____ ()
- 1.13 Fire Resistive Substitution (Sec. 508):
- 1.13.1 1-hour construction waived due to use of automatic sprinkler system? ____ Yes, ____ No
- 1.14 Square Foot per Floor: _____ SF/m²
- 1.15 Number of Floors: _____
- 1.16 Height per Floor: _____ FT/m
- 1.17 Total Building Height: _____ FT/m

1.18 Fire Resistance of Exterior Walls (Table 5-A; For hazardous Waste Storage refer to MIL-HDBK-1008B):

_____ Hours less than _____ Ft/m

_____ Hours less than _____ Ft/m

1.19 Openings In Exterior Walls (Table 5-A):

Not Permitted less than _____ Ft/m

Protected less than _____ Ft/m

**2. FIRE RESISTIVE REQUIREMENTS:
(MIL-HDBK-1008B AND UBC TABLE 6-A)**

2.1 Exterior Bearing Walls: _____ Hours

2.2 Interior Bearing Walls: _____ Hours

2.3 Exterior Nonbearing Walls: _____ Hours

2.4 Structural Frame: _____ Hours

2.5 Partitions - Permanent: _____ Hours

2.6 Shaft Enclosures: _____ Hours

2.7 Floors - Ceilings/Floors: _____ Hours

2.8 Roofs - Ceilings/Roofs: _____ Hours

2.9 Exterior Doors and Windows: _____ Hours

2.10 Stairway Construction: _____ Hours

**3. ROOF ACCESS FOR MANUAL FIRE FIGHTING
(MIL-HDBK-1008B, N.F.P.A 1)**

3.1 Fire Fighting Access to Roof: ___ Yes , ___ No

Hatch Size : _____ SF/m² with minimum dimension of 2 FT or 610mm

3.2 Fire Vehicle Access: Yes No

Access Width _____ FT/m.

No of Sides Access _____ FT/m.

**4. FIRE PROTECTION SYSTEMS
(MIL-HDBK 1008B AND NFPA CODES):**

4.1 Type of Fire Protection System Proposed:

4.1.1 Gaseous Extinguishing System (Total Flooding):

4.1.1.1 Under Floor: _____ Ceiling Area: _____
CO2: _____ Other Clean Agent: _____

4.1.2 Sprinkler System:

4.1.2.1 Wet Pipe System: Yes No

4.1.2.2 Dry Pipe System: Yes No

4.1.2.3 Pre-Action System: Yes No

4.1.2.4 Deluge System: Yes No

4.1.2.5 Standpipe (Class I): Yes No

4.1.2.6 Occupancy Hazard Classification: _____

Discharge Density: _____ Gal/Min/Sq Ft or L/s/mm

Discharge Area: 3000 Sq Ft or 279 square meters

4.1.2.7 Minimum underground main size: 6 inch or 153mm

4.1.2.8 Fire Flow Information:

Flow Hydrant Location/No. _____

Static Pressure _____ psi (kPa)

Residual Pressure: _____ psi (kPa)

Available flow: _____ gpm (L/s)

4.1.3 Fire Pump Size, If Required:

Rating: _____ gpm (L/s) at ____ psi (kPa)

4.2 Manual Fire Alarm/Detection System Description:

4.3 Hydrants (MIL-HDBK-1008B):

Minimum no. of hydrants required by flow (gpm) or (L/s) _____

Type: _____ (Wet) _____ (Dry)

Spacing: _____ FT (M) (Between Hydrants)

Minimum Size of Lateral Main : 6 IN (153 mm)

4.4 Areas between draft stops in concealed combustible areas not to exceed 3000 SF or 279 m².

4.5 Draft curtain at roof level:

Material: _____ Spacing _____ FT (m)

4.6 Smoke and Heat Vents:..... Yes No

Manual Automatic

5. EXITS (NFPA 101):

5.1 Minimum Egress Requirements:

+Occupancy	SM/SF	No. Person	SM/SF/Person	No. of Exits
_____	_____	_____	_____	_____
_____	_____	_____	_____	_____
_____	_____	_____	_____	_____

5.2 Width of Exits:

Occupant Load _____ x 0.3 = _____ In (mm) - Stair Width

Occupant Load _____ x 0.2 = _____ In (mm) - Other Exits

5.3 Distance To Exits:

With Sprinkler System: _____ Ft (m)

Without Sprinkler System: _____ Ft (m)

5.4 Dead End Corridor Limit: _____ FT (m)

5.5 Corridor Construction: _____ Min/Hour

with sprinkler system

with out sprinkler system

5.6 Corridor Door Rating: _____ Min

5.7 Interior Stairway Rating: _____ Hour

5.8 Exterior Stairway Rating: _____ Hour

5.9 Smokeproof Enclosure Rating: _____ Hour

5.10 Area of Refuge Provided: Yes No

**6. INTERIOR FINISH
(MIL-HDBK-1008B, N.F.P.A 101):**

6.1 Class A B C

Automatic Sprinkler System Exception Applicable When Permitted: Yes No

Attachment C

NOTES

ATTACHMENT D

PROJECT REVIEW ENVIRONMENTAL PERMIT CHECKLIST

HAZARDOUS WASTE	YES	NO
1. Does the project involve a hazardous waste transfer or storage facility?		
2. If yes, will the waste be stored longer than 90 days?		
3. Is the required containment provided for spills?		
4. Are incompatibles stored separately?		
5. Is the floor sloped to allow spill collection or alternatively, are containers elevated to prevent contact with spills?		
6. Is the truck loading apron bermed to collect spills?		
7. Is the facility at least 50 feet (15.24 meters) from the property line?		
8. Is a construction permit required?		
9. Is an operating permit required?		
UNDERGROUND STORAGE TANKS		
10. Does the project involve underground storage of regulated substances?		
11. Will there be closure or removal of an UST?		
12. Will there be installation or modification of an UST?		
13. Is a construction permit required?		
14. Is notification or registration required?		
15. Is leak detection provided?		
16. Is the UST used to store heating oil only for consumptive use on the premises?		
17. Are regulatory design criteria met?		
HAZARDOUS WASTE TANKS		
18. Does the project involve either under or aboveground storage of hazardous waste in tanks?		
19. Will the hazardous waste be stored longer than 90 days?		
20. Is a construction permit required?		
21. Is an operating permit required?		
22. Is notification required?		
23. Is leak detection provided?		
24. Is the tank double walled?		
25. Is the tank compatible with what will be stored?		
26. Is a RCRA permit required?	YES	NO
AIR PERMITS		
27. Does the project involve an air pollution source?		

HAZARDOUS WASTE	YES	NO
28. Compare air source emissions with the Applicable Air Pollution Control District (APCD) state allowable emission standards and determine if permit application is required		
29. Will toxic air containment's present require a health risk assessment?		
30. Will equipment noted on enclosed list be installed or modified?		
31. Are regulated operations or sources such as boilers incinerators, petroleum storage tanks, fire-fighting training munition disposal by burning, plating, sandblasting, rocket and jet engine testing, asbestos application by spraying, fuel-transfer, or painting involved?		
32. Are there other potential air sources?		
33. Is a construction permit required?		
34. Will new source Best Available Control Technology (BACT), Air Quality Modeling (AQM), Lowest Achievable Emission Rate (LAER) and offsets to meet requirements of new sources review regulations?		
35. Are other regulatory agency permits required?		
36. Are emission controls provided (Particulate, SOX, VOC, etc.)?		
37. Will there be an air emission source from an Installation Restoration Program (IRP) removal or remedial project?		
38. If yes, will a CERCLA permit exemption apply? (Remedial action conducted entirely on-site)		
VAPOR RECOVERY		
39. Does the project involve a gasoline filling station?		
40. Is a stage I and/or a stage II vapor recovery system required?		
41. Are permits required?		
ACQUISITION OF LAND/BUILDING		
42. Does the project involve land or building acquisition?		
43. Has an environmental site survey been completed?		
44. Is the site known to have been used to store, handle, or dispose of hazardous materials/wastes?		
45. Is the site, or has it been, occupied by bulk storage tanks?		
46. Is asbestos present or likely to be present?		
47. Are PCB transformers present?		
48. Will necessary permits require environmental testing/cleanup?		

	YES	NO
49. Will public hearing be required?		
DEMOLITION		
50. Does the project involve demolition?		
51. Is asbestos present or likely to be present?		
52. Will asbestos removal notification be required?		
53. Is lead paint present?		
54. Are PCB transformers present?		
55. Are any permits required, including concurrence from State Historic Preservation Office on historic/cultural resources?		
56. Are underground storage tanks present?		
WITHDRAWAL FROM AQUIFERS		
57. Does the project involve water withdrawal from an aquifer?		
58. If yes, is the aquifer sole-source?		
59. Is notification required?		
60. Are any permits required?		
61. Is water withdrawal a result of an Installation Restoration removal or remedial action project?		
62. If yes, will a CERCLA permit exemption apply?		
WATER PERMITS WATER WITHDRAWALS SURFACE WATER WITHDRAWALS		
63. Does the project involve the withdrawal of water from surface water sources for domestic (potable) uses or industrial usage?		
64. Is a water allocation permit required?		
65. Are construction permits required for intake structures?		
66. Is notification of regulatory agencies required?		
GROUND WATER WITHDRAWALS		
67. Does the project involve the direct withdrawal of groundwater for potable, industrial uses or groundwater clean-up?		
68. Is a water allocation permit required?		
69. Is notification of regulatory agencies required?		
70. Are well construction permits required?		
TREATMENT FACILITIES		
71. Does the project include potable water storage (tanks reservoirs) or treatment (disinfection, pH control, filtering) facilities, or expansion of the base wide water distribution system?		
72. If yes, are potable water construction/operating permits needed?	YES	NO
WASTEWATER DISCHARGES DOMESTIC SEWAGE		

73. Will domestic (sanitary) sewage be discharged from the project?		
74. Does the project discharge to a sanitary sewage collection system?		
75. Will new sewer mains be constructed or will the effluent flow increase?		
76. Are construction, operating or sewer extension permits required?		
77. Does the discharge flow to a Navy owned STP?		
78. Will the discharge affect the ability of the sewage treatment plant to meet the flow parameters of the NPDES permit? (if yes, a new permit may be required)		
79. Is notification of regulatory agencies required?		
80. Does the discharge flow to a publicly owned treatment plant?		
81. Is notification required?		
82. Is a connection permit required?		
83. Does the discharge flow to a septic system?		
84. Is the septic system new?		
85. Is a construction permit required?		
86. Is a discharge (to groundwater) permit required?		
87. Is the septic system existing?		
88. Does it have a permit?		
89. Are there flow limitations?		
90. Is notification of increased flow required?		
91. Does the project involve the construction of a sewage treatment plant?		
92. If yes, is a NPDES permit required?		
INDUSTRIAL DISCHARGES		
93. Is there going to be a discharge of industrial wastewater from the facility? An industrial discharge can be considered any wastewater generated by any source other than sanitary facilities, such as sinks, urinals, water closets, and floor drains. Examples are photographic labs, laundries, plating operations, pesticide-formulation operations, hospitals, explosive manufacturing, numerous organic and inorganic chemical processes, and cooling and blow-down water from boilers.		
94. Is the discharge going to flow into a sanitary sewage collection system?		
95. If yes, is pretreatment required?		
96. If yes, is a permit required? (Local ordinances may be required for permits for any industrial connection)		
97. Is the discharge going to flow to a storm sewer system, surface water or groundwater?	YES	NO
98. If yes, is a NPDES permit required?		
99. Construction permits may be required for out fall structures or wells		

100. Will there be a discharge to the sanitary sewer from an Installation Restoration Program removal or remedial action project?		
101. If yes, is a permit required?		
STORM WATER DISCHARGES		
102. Facilities that “discharge storm water associated with industrial activity,” include any site where certain activities are performed. Projects that propose to perform any industrial activity may require (1) modification of an existing NPDES storm water permit or, (2) submission of an application for a new permit. NPDES permits will also be needed if a facility, currently without a permit, constructs an industrial facility		
103. Does the project involve construction activities that disturb more than 5 acres?		
104. If yes, is a NPDES permit required?		
105. Will there be discharge to the storm sewer from an installation Restoration Program removal or remedial action project?		
106. If yes, will a NPDES permit be required?		
CORPS OF ENGINEERS PERMITS		
107. Does the project describe work in or adjacent to the coastal zone or aquatic site such as, but not limited to, rivers, streams, lakes, creeks, ponds, estuaries, etc.?		
108. Does the project describe work in or adjacent to wetlands?		
109. Is the project adjacent to or within a wetland or aquatic environment or will have an impact upon a wetland or aquatic environment, has a wetland delineation been completed?		
110. If the project will have an impact upon wetlands, or aquatic environment, has site approval been issued?		
111. Has the wetland delineation been confirmed by the U.S. Army Corps of Engineers or state regulatory agency?		
112. If a coastal zone consistency determination is required, has it been completed?		
113. Does the project require utility runs that might cross wetlands or navigable water? (These may be included in other projects)		
114. Does the project include or require access roads that cross wetlands or navigable water?		
115. Does the project include construction of intake/discharge structures or headwall within a wetland or waterway?		
STATE WETLANDS PERMITS		
116. Does the state in which the project is sited have wetlands and/or dredging regulations which may apply to the projects?		
STATE WATER QUALITY CERTIFICATION		
118. Does the project require state review and approval under the provisions of Section 401, of the Clean Water Act? (Water Quality Certification)		
APPLIED BIOLOGY PROJECTS		
119. Does the project include installation or maintenance of wood piles, poles, or ties?		
120. Is the project a waterfront structure, pier wharf or bulkhead?		
121. Does the project include wood structural components?		
122. Does the project include landscaping with plants or maintenance of turf, shrubs or trees?		

123. Does the project include the application of pesticides other than for the prevention of termites?		
124. Has pre-construction treatment to prevent termites (NFGS 02284) been omitted from the specification?		
125. Is pre-construction treatment to prevent termites other than as specified in NFGS 02285?		
ASBESTOS REMOVAL		
126. Does the project include the construction, repair or rehabilitation of food service or food storage facilities?		
127. Does the project involve potential disturbance of asbestos?		
128. Has an asbestos survey been performed?		
129. Does the project involve renovation, demolition or repair work?		
130. Is federal, state or local notification required?		
131. Are any state or local permits required?		
132. Is third party monitoring required or recommended?		
133. Is the NAVFAC spec section 02080 included and edited correctly?		
LEAD PAINT REMOVAL		
134. Does the project involve potential disturbance of lead paint?		
135. Had a lead paint survey been performed?		
136. Does the project involve renovation, demolition or repair work?		
137. Is federal, state or local notification required?		
138. Are any state or local permits required?		

Attachment D-1
EQUIPMENT REQUIRING PERMITS

1. Abrasive Blasting Equipment (Pot & Nozzle)
2. Asphalt Roofing Kettles
3. Asphalt Tankers
4. Hot-Mix Asphalt Paving Batch Plants
5. Abrasive Blasting Cabinets, Rooms and Booths
6. Tire Buffers
7. Sand, Rock and Aggregate Screens
8. Boilers, Heaters, Gas Turbines and Asphalt Heaters
9. Concrete Batch, Block or Pipe Plants, or Mixers Over 1 Cubic Yard
10. Non-Municipal Incinerators
11. Burn-Out Ovens
12. Core Ovens
13. Metal Melting and Sweating Furnaces
14. Concrete-Treated-Base (CTB) Plants
15. Rock & Aggregate Plants
16. Brick Plants
17. Salt Bath Heat Treat Furnaces
18. Cupola Furnaces for Gray Iron Production
19. Bulk Dry Chemical Transfer and Storage Facility Equipment
20. Gasoline & JP-4 Fuel Storage and Transfer at Fuel Farms
21. Gasoline Service Station Storage & Transfer to Trucks & Automotive Vehicles
22. Paint Spray Booths
23. Curing or Baking Ovens
24. Degreasers (Vapor and Cold)
25. Paint or Solvent Diptanks, Solder Levelers, Roller-Coatings Machines, Driers and Miscellaneous Equipment Using Materials Containing Organic Solvents
26. Dry Cleaning Facilities Using Halogenated Hydrocarbon Solvents
27. Dry Cleaning Facilities Using Petroleum Base Solvents
28. Chrome Electroplating, Anodizing, Chemical Milling and Other Material Preparation Equipment Using Inorganic Chemicals
29. Brake Debonders
30. Waste Disposal Shredder Units
31. Waste Disposal Air Classified Units
32. Waste Disposal Drier Units
33. Waste Disposal Pyrolysis Reactor Units
34. Gas Turbine Test Cells, Aircraft Engine Testing (Non-Shaft Engines)
35. Gas Turbine Test Cells, (Shaft Engine Testing)
36. Piston Type Internal Combustion Engines
37. Grinding Booths and Rooms
38. Organic Gas Sterilizers
39. Surface Coating Application Stations (Metal Parts, Marine, Aerospace & Automotive Coatings)
40. Municipal Waste Storage & Processing
41. Industrial Waste Water Treatment
42. Air Stripping & Soil Remediation Equipment
43. Sewage Treatment Facilities
44. Fire Fighting Training Facility

Attachment D-1

NOTES

ATTACHMENT E

OPERATION AND MAINTENANCE SUPPORT INFORMATION (OMSI)

INTRODUCTION

1. The Operation and Maintenance Support Information (OMSI) concept was developed to help activities operate, maintain, and repair selected facilities. Produced during the facility's construction, OMSI manuals provide an organized library of data on as-built materials, systems, and equipment. Because of the comprehensive nature of these manuals, they are used as the first step toward solving operation, maintenance, or repair problems.

2. The OMSI User Manual consists mainly of construction contractor submittals for as-built materials/equipment, such as Manufacturer's Catalog Data, Shop Drawings, Parts Lists, Test Reports, and Operation and Maintenance Data, assembled and indexed in a comprehensive manual. The User Manual may also provide more detailed information on operation, maintenance, repair and troubleshooting for selected key systems such as Fire Protection, Roofing, and Heating, Ventilating and Air Conditioning (HVAC). The User Manual is organized by divisions and sections corresponding to the divisions and sections of the construction specifications. For example, if you wanted to find information about interior electrical wiring, you would look under Division 16, "Electrical", and then under Section 16402, "Interior Wiring Systems". A specification table of contents is located at the front of each manual volume. The specification sections for Division 1 are not applicable for OMSI, so this division is used for general facility information such as floor area, overall dimensions, utility cut-off locations, etc.

3. An OMSI Operation and Maintenance Manual consists of selected systems requiring operation, maintenance, and repair procedures. Each system in the manual consists of four sections: Operation, Preventive Maintenance, Corrective Maintenance, and Appendix. For each section, the manual may provide extensive additional information such as emergency operating procedures, troubleshooting, and warranty provisions.

4. NAVFAC Guide Specification NFGS-01730 has been written to require the construction contractor to furnish operation and maintenance data. For projects that include the OMSI requirement, this data is provided to the A-E who will develop the OMSI package. All NFGS sections that have operation and maintenance requirements have been coordinated with NFGS-01730.

USER MANUAL

GENERIC CONTENTS

DIVISION 1 - GENERAL

1. OMSI Type. Indicate the type of OMSI (A or C) provided for the facility. If a Type A is being provided, state the specific systems which are covered by the OMSI Operation and Maintenance Manual.

2. Facility Information. As applicable, provide the following data which is useful for maintenance services of the facility (tabular and concise narrative format is desired with photographs as appropriate) :

a. General Description of Facility : Function of facility, overall width, length, and height, number of floors, crawl space/slab/basement, normal number of occupants.

*b. Type and Number of Systems/Zones for: Heating, ventilation, and air conditioning (HVAC), fire protection, intrusion detection, emergency power, and other major systems. Provide an equipment inventory showing item descriptions, model numbers, and manufacturers and suppliers names and addresses (if available). Listing should be limited to major components such as shown on design equipment schedules.

c. Number, type and size of each filter used in HVAC system .

d. Net Area of Facility Broken Down by Type of Space and Floor Covering, e.g.: office carpet, corridor carpet, office vinyl tile, corridor vinyl tile, bathroom/lavatory ceramic tile, playing court hardwood, shop/mechanical room concrete, etc.

e. Total areas each of painted wall and ceiling surfaces; ceramic tile wall and ceiling surfaces; suspended ceiling surfaces.

f. Total area of roof broken down by type of roof surface/system.

g. Number, types, and size of windows; indicate special features such as tilt-in sash for cleaning.

h. Total number and types of light fixtures, including number and types of bulbs/tubes required.

i. Number of bathroom fixtures, including number of sinks, commodes, lavatories, and urinals.

j. Beneficial Occupancy Date (B.O.D.).

k. Basis of Design.

*For Type C OMSI, provide cross reference here to the appropriate User Manual specification section for expanded information on the operation, maintenance and repair of these systems. For Type A OMSI, cross reference here if system is included in the OMSI Operation and Maintenance Manual.

3. Floor Plans & Site Plans. Provide legible small scale floor and site plans.
4. Utility Connection/Cutoff Points. Denote the main interior and exterior connection and cutoff points for all utilities on small scale floor and site plans. Plans should contain enough information to make the location of the connection/cutoff points obvious to someone unfamiliar with the facility and should denote which system, area, or portion of a system it controls. Where applicable, clearly indicate the room number, panel number, valve number, etc., of the respective utility being identified.
5. As-built Drawing List. List the as-built drawings by title and sheet numbers and identify where the drawings and specifications will be kept on file.
6. Extended Warranty Information. Provide special/extended warranty information to the extent that it is available from data submitted by the contractor or available from the ROICC office. An extended warranty is defined as a warranty exceeding one year and may cover parts, labor or both such as warranties for A/C compressors, hot water heaters and water coolers. The A-E will not be required to contact manufacturers to obtain warranty data on equipment and material where this data has not been provided by the contractor or where the ROICC has not required the contractor to furnish such data. List each item which has special warranty information and include the written guarantee or warranty for the item. The list shall state the applicable specification section, duration of the warranty, start and ending dates of the warranty, point of contact for fulfillment of the warranty, and required operational and general service maintenance to be performed by the Government to maintain the manufacturer's special warranty agreement. Roofing systems warranty information shall be included here with special cross reference to the roofing specification section.

DIVISIONS 2 THROUGH 16

1. For each specification section, the User Manual shall provide an as-built record of materials and built-in equipment used in the construction. This should include all as-built materials and equipment for which manufacturer's data submittals were made in accordance with the construction specifications. Information to be provided includes a

description and model number of the item; name, address, and telephone number of the manufacturer and supplier; and where the material was used. Catalog cuts and manufacturer's data sheets are examples of applicable sources for fulfillment of this requirement. Include shop drawings as appropriate based on specific relevance to operation, maintenance, repair and alteration of the facility or system. Shop drawings should be reduced to 16" x 22" (406mm x 558mm) maximum and submitted in pocket folders organized by specification section and permanently attached to the binder. Each pocket folder is to be labeled indicating content. Extraneous data should not be included in the manual. For example, if manufacturer's data sheets are composed such that information on several part numbers or model numbers is shown, the as-built material should be highlighted or otherwise noted and the extraneous sheets should be removed and discarded. Insert all operation and maintenance data furnished in accordance with the construction specification in the applicable Division/Section of the User Manual. If an Operation and Maintenance Manual is provided for this project, the contractor submitted Operation and Maintenance Data Packages for the selected systems must be incorporated into the Operation and Maintenance Manual but cross-referenced in the User Manual.

2. Under the roofing specification section, provide separate sheet(s) with the following information for each roofing system: name of roofing product/system; manufacturer's, supplier's, and installer's name, address, and phone number; warranty period and manufacturer's specific requirements to maintain warranty; methods and materials for maintenance, repair, and modification, including prohibited practices; roof structural load limits; maintenance inspection and service checklists with recommended schedule.

3. Under the corresponding specification section, provide the information shown in paragraph 3a, b, c, and d below for the following systems: Heating, Ventilating and Cooling (HVAC) System, Space Temperature Control System, Fire Extinguishing Systems, and Fire Alarm Systems. This information is in addition to the requirements of Divisions 2-16, paragraph 1, and should also include all Operation and Maintenance Data Package information furnished in accordance with the construction specifications.

a. Operation. General system description, concise narrative of system operation including schematics, control diagrams, color coded flow diagrams, start-up/shutdown procedures, normal operating instructions, operating norms, emergency operating instructions, safety and Lock Out/Tag Out instructions, and interconnection with other systems (such as fire protection). HVAC presentation shall reference Testing, Adjusting, Balancing, and Start-up (TABS) final Certified Balance Reports and the Space Temperature Control Systems presentation shall include all Automatic Controls Acceptance Tests (ACATS).

b. Preventive Maintenance. Provide a routine Preventive Maintenance (PM) schedule for each system on those components requiring PM. The PM schedule

should include frequency and details of inspection and service to be accomplished based on manufacturer's recommendations and good engineering practice.

c. Corrective Maintenance. Provide a basic troubleshooting guide to isolate probable causes of typical system malfunctions and recommend corrective procedures. Equipment/component removal, replacement and repair instructions shall refer to the Operation and Maintenance Data Package as submitted by the construction contractor.

d. Environmental Consideration. Identify systems/equipment which require environmental operation, reporting, testing, analysis or inspection to comply with Federal and related state/local environmental laws and their respective implementing regulations, statutes, policies, etc. For each system/equipment, describe the required procedure and frequency for environmental operation, reporting, testing, analysis and inspection.

NOTE: If an OMSI Operation and Maintenance Manual is also to be prepared for systems of this facility, it is generally not necessary to duplicate information included in those manuals into this User Manual. However, if the information also applies to other systems, the data may be duplicated for the applicable sections of the User Manual.

SUBMITTAL REQUIREMENTS

1. Concept Submittal (2 hard copies required). The Concept Submittal should include the cover sheet and spine inserts, table of contents, binders and dividers, and other materials as necessary to demonstrate the proposed physical arrangement of the manuals and the quality of the copies, dividers and tabs. In addition, the Concept Submittal should include the information of Division 1 and one other selected division. These divisions should be presented in sufficient detail to evaluate the data collection and arrangement process. The marked-up construction Submittal Matrix should also be forwarded for review. Photocopies of contractor's submittals are acceptable for this submittal. This submittal shall be delivered to SOUTHWEST DIVISION.

2. Prefinal Submittal. (2 hard copies required). The manual at 90 percent or more completion. Because the prefinal User Manual will actually be used by the activity, it should contain all the required information that is available at the time of submission. Approved binders are required for this submittal. One copy shall be delivered to SOUTHWEST DIVISION and one copy shall be delivered to the designated point of contact at the activity. Review comments on the prefinal submittal may be provided to the A-E at various times after facility start-up and approximately 60 days before due date of the final User Manual. These comments will address recommendations and problems encountered during ongoing operation and maintenance of the facility. The hard copies will be returned to the A-E no later than 60 days before the due date of the final User Manual.

3. Final Submittal. (3 hard copies, 2 microfilm copies required). One hard copy (the "master" copy) that is a complete finished product, must be maintained by the A-E. This copy should be used for making corrections and microfilm copies while waiting for the copies from the activity and SOUTHWEST DIVISION to be returned. The hard copies and microfilm copies of the final submittal must address the comments made during all previous reviews. A copy of the prefinal review comment sheet with the A-E's response to each item shall be forwarded with the final submittal. One hard copy and one microfilm copy shall be delivered to SOUTHWEST DIVISION; two hard copies (including the "master" copy) and one microfilm copy shall be delivered to the designated point of contact at the activity.

- a. Hard Copy. The final manual shall be bound in durable, red, hard cover, spring post loose-leaf binders that are water and grease resistant. The final binders shall be for 8 ½" x 11" sheet size and have a three-inch thick capacity. Typical binders will have a clear pocket located on the front which will accept an 8 ½" x 11" sheet size paper and a spine pocket which will hold a printed sheet that identifies the project title, project number, location, construction contract number and volume number. Sheets in the manual shall be high quality paper and the dividers shall be heavy duty paper with plastic reinforced holes and tabs. Tabs shall be provided to show the Specification Section number with keywords to identify the section title, major

equipment groups, i.e., valves, pumps, chillers, control panels, sensors, etc., and the topics of Division 1. Tabs shall also be provided to identify all O & M data and its contents. Instruction sheets, drawings, etc., larger than 8 ½" x 11", but not exceeding 16" x 22" shall be inserted into the binders as single fold-out sheets which may be punched or clipped into the binder or inserted into pockets attached to heavy duty paper. Large O&M manuals and large drawings such as key shop drawings which cannot be reduced may be inserted in stiff paper or clear plastic pockets. Because loose material is easily lost, use of pockets should be kept to a minimum. A Master Table of Contents for all volumes shall be provided at the front of each volume. As appropriate, the following statement is to appear at the bottom of each page of the table of contents: "An OMSI Operation and Maintenance Manual has also been prepared for selected systems of this facility. Therefore, if some system data is not found in this User Manual, it may be available in the Operation and Maintenance Manual."

- b. Microfilm Copy. In addition to submitting hard copy sets of the final User Manual, also required are two sets in a microfilm format (35mm cartridge). Each set should be self-contained within one or more microfilm(s). Cartridge containers should be prepared, filmed, and included in each microfilm for each set, after the binder cover sheet. If more than one microfilm is used to film each set, the Master Index should so indicate. The first page of the Master Index should show the following heading information: Type of OMSI Manual; project title and location; project number and construction contract number; number and title of the volumes and their respective contents. The Master Index should be to the level of the hardcopy Master Table of Contents. The intent of the Master Index is to quickly locate data contained in the microfilm.

OPERATION AND MAINTENANCE MANUAL
GENERIC CONTENTS

Section A - Operation

1. General System Description - provides an overview of as-built system composition and operation of system.
2. Start-up and Shutdown Procedures provides step by step instructions to bring as-built systems from static to operational configurations and from operating to shutdown.
3. Normal Operating Instructions - includes control diagrams with data to explain operation and control of as-built system and specific equipment.
4. Operating Norms - provides temperatures, pressures, flow rates, etc. to be expected during normal operation of the as-built system.
5. Emergency Operating Instructions - includes emergency procedures for equipment malfunctions to permit a short period of continued operation or to shutdown the equipment to prevent further damage to the as-built system and equipment; provides emergency shutdown instructions for fire, explosion, spills, or any contingency; and provides guidance on emergency operations of all utility systems including valve locations and portions of systems controlled.
6. Environmental Considerations - includes a listing of as-built systems/equipment which require special environmental operation, reporting, testing, analysis or inspection to comply with Federal and related state/local environmental laws and their respective implementing regulations, statutes, policies, etc. Examples are backflow preventer inspections, underground storage tank testing, hazardous material/waste usage and storage documentation, and inspection and testing of air pollution control devices. For each system/equipment, describe the required procedure and frequency for environmental operation, reporting, testing, analysis and inspection.
7. Important and Special Considerations - contains items of special interest concerning system design, as-built construction, or operation; and provides a list of environmental conditions (temperature, humidity, and other relevant data) which are best suited for each piece of equipment and those conditions under which the equipment should not be allowed to run.
8. Test Procedures and Scheduling - provides procedures for as-built system/equipment tests not performed as recurring preventive maintenance.

9. Operator Servicing Requirements - includes instructions for services to be performed by the operator such as lubrication, adjustments, and inspection on the as-built equipment / system.
10. Safety Instructions - provides personnel hazards and as-built equipment safety precautions for all operating conditions, including Lock Out / Tag Out instructions.
11. Flow diagrams - contains drawings indicating as-built system liquid, air or gas flow during normal operations.
12. Diagrammatic Plans - provides plans, by floor, of actual installed system.
13. Valve List - includes as-built listing and location of all major valves associated with the system. The construction contractor will normally physically mark the valves with permanent type tags/labels to include a consecutive identifying number.
14. Operation Records - includes forms, samples, and instructions for keeping necessary operating records of the as-built systems and equipment.
15. Special Warranty Conditions - provides guidance/instructions necessary for the operator to follow to keep all warranties valid for as-built equipment and systems.

Section B - Preventive Maintenance

1. Preventive Maintenance Plan and Schedule - provides a maintenance plan for each piece of as-built equipment which shall be in accordance with the manufacturers' recommended maintenance, good engineering practice, and other historical information to include skill level, frequency and time required for each check; provides an annual schedule by week to accomplish the required maintenance at the necessary frequency.
2. Work Orders / Task Cards - provides individual maintenance tasks taken from the maintenance plan and printed on cards which can be used as a work order to facilitate the performance of the required preventive maintenance by the mechanic assigned to do the specified work. Cards shall also include information on special tools needed, safety precautions, Lock Out/Tag Out instructions and environmental considerations.
3. Lubrication Instructions (other than those by operator) - includes a table showing recommended lubricants for specific temperature ranges and applications; chart (s) with schematic diagram of the as-built equipment showing lubrication points, recommended types and grades of lubricants, and capacities; a lubrication schedule showing service interval frequency.
4. Instructions for Maintaining a Log of Preventive Maintenance Accomplished - to provide a system of work management where the accomplishment of preventive

maintenance may be recorded, monitored and controlled by either hand or computer method.

Section C - Corrective Maintenance

1. Troubleshooting Guides and Diagnostic Techniques - includes step by step procedures to promptly isolate the cause of malfunctions of as-built systems and equipment, describes clearly where and how the checkout is performed and what conditions are to be sought; identifies tests or inspections and test equipment required for troubleshooting procedures. In general, the troubleshooting guides for this manual should be carried to the level of cross referencing the contractor provided manufacturer's troubleshooting data for the constituent equipment, parts or components of the systems.
2. Maintenance and Repair Procedures - provides maintenance and repair instructions and the list of tools required to restore as-built equipment to proper operating standards. Include safety, Lock Out/Tag Out and environmental instructions.
3. Removal and Replacement Instructions - includes step by step procedures presented as a combination of text and illustrations and a list of tools and supplies required for removal, replacement, disassembly, and assembly of components, assemblies, subassemblies, accessories, and attachments; provides the tolerances, dimensions, settings, and adjustments required. Include safety, Lock Out/Tag Out and environmental instructions.
4. Instructions for Maintaining a Log of Corrective Maintenance and Repair Accomplished - to provide a system of work management where the accomplishment of corrective maintenance may be recorded, monitored and controlled by either hand or computer methods; to include history of corrective maintenance actions, parts used, time required, etc. for a given piece of equipment or system.

Section D - Appendix

General - All items included in the Appendix must be paged, indexed and properly cross

referenced throughout the text of the manual in Section A, B and C.

1. Inventory of Equipment - a listing of all equipment identifying nomenclature such as make, model, serial number, size, location, etc. for each item.
2. Operation and Maintenance Data - Include Operation and Maintenance Data Package information provided by the construction contractor per Section 01730 and the technical sections of the specification. This information must also be incorporated into the preparation of each system discussion under the Operation,

Preventive Maintenance and Corrective Maintenance sections of the Operation and Maintenance Manual.

3. Manufacturer's Equipment Information includes drawings, illustrations, and technical data furnished by the manufacturer for the equipment and system components and organized/indexed for easy reference.
4. Parts Lists - provide identification and coverage for all parts of components, assemblies, subassemblies, and accessories of the end items subject to replacement; specify special hardware requirements, e.g., high strength bolts and nuts; identify parts by make, model, serial number, and source of supply to allow reordering without further identification; include clear and legible illustrations, drawings, and exploded views to enable easy identification of the items; shows index/reference/key number which will cross-reference the illustrated part to the listed part; parts shown in the listings shall be grouped by components, assemblies, and sub-assemblies with individual parts identified to the assembly.
5. Warranty Information - lists each piece of equipment furnished by the construction contract and includes the written guarantees of such equipment. The equipment list shall state the specification section applicable to the equipment, duration of the warranty, start date of the warranty, ending date of the warranty, and the point of contact for fulfillment of the warranty; provides a listing of required operational and general service maintenance to be performed by the Government to maintain the manufacturer's warranty agreement; provides a listing of all shipping and packaging requirements to send off for repair if applicable.
6. Personnel Staffing and Training Requirements - includes the number and classification of people needed to operate and maintain the facility; provides an operating and maintenance indoctrination program which shall include formal classroom instruction, on-the-job training, and necessary audio-visual "canned" instruction that can be maintained on file by the Government for indoctrinating future operations/maintenance personnel.
7. Testing Equipment and Special Tools Required - includes information on the test equipment required to perform specified tests and special tools needed for the operation, maintenance, and repair of components.
8. Inspection Plan - provides an occupant inspection checklist of major components of the facility and establishes a Public Works Department inspection guide developed from NAVFAC MO-322.
9. Supply Inventory Requirements - lists spare parts, fuels, lubricants, etc. required for maintenance and repair to ensure continued operation without unreasonable delays; reflects special consideration if facility is at a remote location; lists parts and supplies having long lead times to obtain.

10. Names, Addresses and Telephone Numbers of Manufacturers, Suppliers and Contractors/Subcontractors - list by applicable equipment, system, and section of the construction specifications.
11. Bibliography - contains listing of reference materials used in preparation of the O&M Manual.
12. Glossary - list of difficult or technical terms used in the O&M Manual with explanations/meanings.
13. As-Built Drawings and Specifications - list drawings by titles and sheet numbers, description of the specifications and identifies the location where they will be kept on file.
14. Permits and Standards - lists the permits and standards that were issued for the facility and includes the written documents themselves.

SUBMITTAL REQUIREMENTS

1. Concept Submittal (2 hard copies required). The purpose of this submittal is to present, for approval, an overall plan to be followed during the ongoing preparation of the manual. One copy shall be delivered to SOUTHWEST DIVISION and one copy shall be delivered to the designated point of contact at the activity. This submittal shall include but not be limited to providing the following information:

1. Identify by name all systems that will be addressed in the manual.
2. Provide the format and table of contents of the manual and include the following:
 - a. Sample spring post loose-leaf binder. Show a typical title as it will appear on the front face and also on the spine of the binder.
 - b. Proposed divider format with sampler divider and completed tab.
 - c. Samples showing the quality of paper and the quality of reproduction proposed.
 - d. Select one system of moderate complexity and partially develop the various operational and maintenance aspects of the system. This development should have sufficient depth to clearly demonstrate the arrangement and level of detail proposed for all systems that will be included.

2. Prefinal Submittal (3 hard copies required). The manual at a minimum of 90 percent completion. This submittal should contain all the required information available at the time of submission to begin detailed operation and maintenance of the facility. Binders approved during the SOUTHWEST DIVISION review of the concept submittal are required for this submittal. One hard copy (the “master” copy) must be retained by the A-E. One copy shall be delivered to SOUTHWEST DIVISION and one copy shall be delivered to the designated point of contact at the activity. As necessary, SOUTHWEST DIVISION will provide review comments to the A-E regarding the prefinal submittal. These comments will be provided after site validation, so that problems discovered during review, site validation, and facility start-up can be addressed by the final submittal. Additional comments may also be provided by SOUTHWEST DIVISION and the activity after the Beneficial Occupancy Date (B.O.D.) to address problems encountered during the ongoing operation and maintenance of the facility. The hard copies from SOUTHWEST DIVISION and the activity will be returned approximately 60 days before the due date of the Final Submittal.

3. Final Submittal (3 hard copies, 2 microfilm copies required) The master copy should be retained by the A-E for making corrections and for making the microfilm copies while waiting for the copies from SOUTHWEST DIVISION and the activity to be returned. The hard copies and microfilm copies of the final submittal must address the comments made during all previous reviews and during the validation. A copy of the prefinal review comment sheet with the A-E’s response to each item shall be forwarded with the final submittal. One hard copy and one microfilm copy shall be delivered to SOUTHWEST DIVISION; two hard copies (including the “master” copy) and one microfilm copy shall be delivered to the designated point of contact at the activity.

a. Hard Copy

1. The final manual shall be bound in durable, hard cover, blue, spring post loose leaf binders that are water and grease resistant. The binders shall be for 8 ½” x 11” sheet size and have a three inch thick capacity. Typical binders will have a clear pocket located on the front and spine which will hold a printed sheet that identifies the project title, project number, location, construction contract number, volume number and the system(s) included in that volume. Each binder shall be referred to as a single volume. If possible, all sections of a system should be contained in a single binder. Multiple systems may be contained in a single binder provided that all sections of a system are included in the same binder.

2. Sheets in the manual shall be high quality paper and the dividers shall be heavy duty paper with plastic reinforced holes and tabs. Tabs shall be provided to identify the System title, the different sections under each system such as “Operation,” “Preventive Maintenance,” “Corrective Maintenance,” and “Appendix,” and the major topics under each section.

Tabs shall also be provided to identify the title of each O & M Data Package and its contents.

3. Instruction sheets, drawings, etc., larger than 8 ½" x 11" (215.9mm x 279,4mm) but not exceeding 16" x 22" (406.4mm x 558.8mm) shall be inserted into the binders as single fold-out sheets. Large O&M manuals and large drawings such as key shop drawings which cannot be reduced may be inserted in stiff paper or clear plastic pockets. Because loose material is easily lost, use of pockets should be kept to a minimum.

4. A master table of contents for all volumes shall be provided at the front of each volume. The following statement should appear at the bottom of each page of the master table of contents: "An OMSI User Manual has also been prepared for this facility. If product data for components/materials of the systems covered by this Operation and Maintenance Manual cannot be found, it may be contained in the applicable specification section of the User Manual."

5. Microfilm Copy. In addition to submitting hard copy sets of the final Operation & Maintenance Manual, also required are two sets in a microfilm format (35mm cartridge). Each set should be self-contained within one or more microfilm(s). Cartridge containers should be labeled as to their contents. A Master Index should be prepared, filmed, and included in each microfilm for each set, after the binder cover sheet and preface sheet. If more than one microfilm is used to film each set, the Master Index should so indicate. The first page of the Master Index should show the following heading information: Type of OMSI Manual; project title and location; project number and construction contract number; number and title of the volumes and their respective contents. The Master Index should be to the level of detail of the hard copy Master Table of Contents. The intent of the Master Index is to quickly locate data contained in the microfilm.

Attachment E