

**FINAL
RECORD OF DECISION**

OPERABLE UNIT 1

**NAVAL AIR STATION (NAS) WHIDBEY ISLAND
OAK HARBOR, WASHINGTON**

**PREPARED BY
URS CONSULTANTS, INC.
SEATTLE, WASHINGTON**

**PREPARED FOR
ENGINEERING FIELD ACTIVITY, NORTHWEST
NAVAL FACILITIES ENGINEERING COMMAND
SILVERDALE, WASHINGTON**

DECEMBER 1993

CONTENTS

<u>Section</u>	<u>Page</u>
1.0 INTRODUCTION	1
2.0 SITE NAME, LOCATION, AND DESCRIPTION	1
2.1 Area 5—Highway 20/Hoffman Road Landfill	1
2.2 Area 6—Landfill Operations Area and Former Hazardous Waste Storage Area	4
3.0 SITE HISTORY AND ENFORCEMENT ACTIVITIES	5
3.1 Site History	5
3.2 Previous Investigations at NAS Whidbey Island	5
4.0 COMMUNITY RELATIONS	7
5.0 SCOPE AND ROLE OF RESPONSE ACTION WITHIN SITE STRATEGY ..	9
6.0 SUMMARY OF SITE CHARACTERISTICS	9
6.1 Geology and Hydrogeology	9
6.2 Nature and Extent of Contamination	12
6.2.1 Calculation of Background Metals Concentrations	12
6.2.2 Area 5 Shallow Aquifer	12
6.2.3 Area 6 Shallow Aquifer	16
6.2.4 Intermediate Aquifer	20
6.2.5 Deep Aquifer	20
6.2.6 Surface Water	21
6.2.7 Sediments	21
6.2.8 Soil	25
7.0 SUMMARY OF SITE RISKS	25
7.1 Human Health Risk Assessment	31
7.1.1 Screening Evaluation to Identify Chemicals and Media of Potential Concern	31
7.1.2 Exposure Assessment	35
7.1.3 Toxicity Assessment	38
7.1.4 Risk Characterization	39
7.1.5 Uncertainty Analysis	42
7.2 Ecological Risk Assessment	46

CONTENTS (Continued)

<u>Section</u>	<u>Page</u>
8.0 REMEDIAL ACTION OBJECTIVES	47
8.1 Need for Remedial Action at Area 6	47
8.2 Area 5	56
9.0 DESCRIPTION OF ALTERNATIVES	56
9.1 Alternatives for Area 6	56
9.1.1 Alternative 1—No Action	57
9.1.2 Alternative 2—Institutional Controls	57
9.1.3 Alternative 3—Groundwater Extraction and Treatment by Air Stripping and Capping Landfill Operations Area With MFS Cap	58
9.1.4 Alternative 4—Groundwater Extraction and Treatment by Air Stripping and Capping Landfill Operations Area With RCRA Cap	59
9.2 Alternatives for Area 5	60
10.0 COMPARATIVE ANALYSIS OF ALTERNATIVES	60
10.1 Overall Protection of Human Health and the Environment	61
10.2 Compliance With ARARs	61
10.3 Long-Term Effectiveness and Permanence	62
10.4 Reduction of Toxicity, Mobility, and Volume Through Treatment	62
10.5 Short-Term Effectiveness	62
10.6 Implementability	63
10.7 Cost	63
10.8 State Acceptance	63
10.9 Community Acceptance	63
11.0 THE SELECTED REMEDY	64
11.1 Area 6 Remedy	64
11.1.1 Area 6 Landfill Cap	66
11.1.2 Groundwater Extraction and Treatment by Air Stripping	66
11.1.3 Groundwater Monitoring—Monitoring Wells	66
11.1.4 Groundwater Monitoring—Private Drinking Water Wells	67
11.1.5 Institutional Controls	67
11.2 Area 5	67

CONTENTS (Continued)

<u>Section</u>	<u>Page</u>
12.0 STATUTORY DETERMINATIONS	68
12.1 Protection of Human Health and the Environment	68
12.2 Compliance With ARARs	68
12.2.1 Action-Specific ARARs	68
12.2.2 Chemical-Specific ARARs	70
12.2.3 Location-Specific ARARs	71
12.2.4 Other Criteria, Advisories, or Guidance	71
12.3 Cost-Effectiveness	71
12.4 Utilization of Permanent Solutions and Alternative Treatment Technologies	71
12.5 Treatment as a Principal Element	71
13.0 DOCUMENTATION OF SIGNIFICANT CHANGES	71
APPENDIX A RESPONSIVENESS SUMMARY	
APPENDIX B ADMINISTRATIVE RECORD INDEX	

FIGURES

	<u>Page</u>
1 Operable Unit 1 Location, NAS Whidbey Island	2
2 Site Map, Areas 5 and 6	3
3 Geologic Cross Section A-A'	10
4 Area 5 Sampling Locations	13
5 Area 6 Sampling Locations	14
6 Concentrations of Volatile Organic Compounds in Soils From Former Hazardous Waste Storage Area	28
7 Conditional Points of Compliance	55

TABLES

	<u>Page</u>
1 Summary of Shallow Aquifer Groundwater Sampling Results for Area 5	15
2 Summary of Area 6 Groundwater Sampling Results	17
3 Surface Water Data for Areas 5 and 6	22
4 Sediment Data for Areas 5 and 6	24
5 Summary of Soil Sampling Results From Former Hazardous Waste Storage Area	26
6 Summary of Soil Sampling Results in All Area 6 Locations Except Former Hazardous Waste Storage Area	29
7 Chemicals of Concern for Area 6 Shallow Groundwater	34
8 Potential Exposure Pathways for Populations at Operable Unit 1	37
9 Toxicity Values for Chemicals Responsible for the Majority of Risks in the Shallow Aquifer at Areas 5 and 6	39
10 Potential Human Health Risks Associated With Future Residential or Occupational Use of Groundwater From the Shallow Aquifer at Area 5	41
11 Well-by-Well Evaluation of the Potential Human Health Risks Associated With Future Residential Use of Groundwater at Area 6	43
12 Chemicals Contributing to Potential Health Risks for the Future Residential Users of Groundwater at Area 6	45
13 Potential Human Health Risks Associated With Future Resident Exposure to Soil at Area 6	46
14 Ecological Hazard Quotients Determined for Terrestrial Receptors	48
15 Ecological Hazard Quotients for Chemicals in Sediment at Areas 5 and 6 . .	49
16 Ecological Hazard Quotients for Chemicals in Surface Water at Areas 5 and 6	51
17 Groundwater Cleanup Levels for Operable Unit 1, NAS Whidbey	54

DECISION SUMMARY

1.0 INTRODUCTION

In accordance with Executive Order 12580, the Comprehensive Environmental Response, Compensation, and Liability Act of 1980 (CERCLA), as amended by the Superfund Amendments and Reauthorization Act of 1986 (SARA), and, to the extent practicable, the National Oil and Hazardous Substances Pollution Contingency Plan, the United States Navy (Navy) is addressing contamination by undertaking remedial action. The selected remedial action has the approval of the United States Environmental Protection Agency (EPA), the concurrence of the Washington State Department of Ecology (Ecology), and is responsive to the expressed concerns of the public. The selected remedial action will comply with applicable or relevant and appropriate requirements (ARARs) promulgated by Ecology, EPA, and other state and federal agencies.

2.0 SITE NAME, LOCATION, AND DESCRIPTION

Naval Air Station (NAS) Whidbey Island, Ault Field, is located on Whidbey Island Ault Field in Island County, Washington, at the north end of Puget Sound and the eastern end of the Strait of Juan de Fuca (Figure 1). The island is 1 to 10 miles wide and almost 40 miles long, oriented north-south. NAS Whidbey Island is located just north of the city of Oak Harbor (population 14,000) and has two separate operations—Ault Field and the Seaplane Base.

Ault Field is divided into four operable units (OUs)—OU 1, 2, 3, and 5. The Seaplane Base is a separately listed Superfund site and constitutes OU 4.

This Record of Decision (ROD) addresses OU 1, which consists of Area 5 and Area 6 at Ault Field. Properties adjacent to OU 1 use groundwater for residential and agricultural purposes. There are approximately 25 private wells within a half-mile radius of OU 1. Areas 5 and 6 are described in the following sections.

2.1 Area 5—Highway 20/Hoffman Road Landfill

Area 5 is approximately 500 feet long by 500 feet wide and was used for gravel excavation (Figure 2). It is located just north of Ault Field Road and west of State Highway 20. Although there is no documentation that hazardous wastes were disposed of at Area 5, it may have been used as a landfill for a year between 1958 and 1959. Pesticides were routinely applied in Area 5 as well as throughout NAS Whidbey Island property to control weeds and pests.

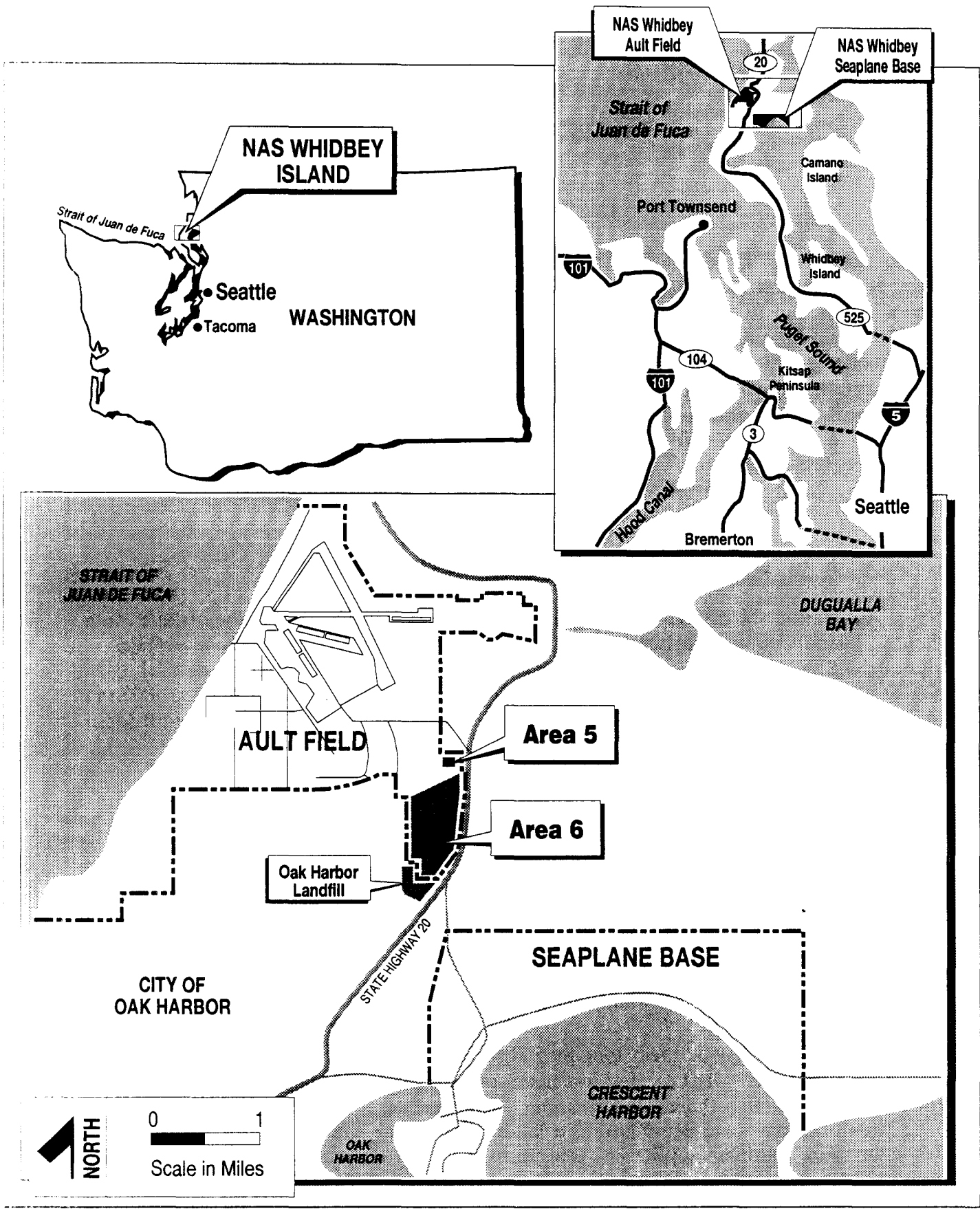

Figure 1
Operable Unit 1 Location
NAS Whidbey Island

CLEAN
 COMPREHENSIVE LONG-TERM ENVIRONMENTAL ACTION NAVY

CTO 0005
 OPERABLE UNIT 1
 NAS WHIDBEY, WA
 ROD

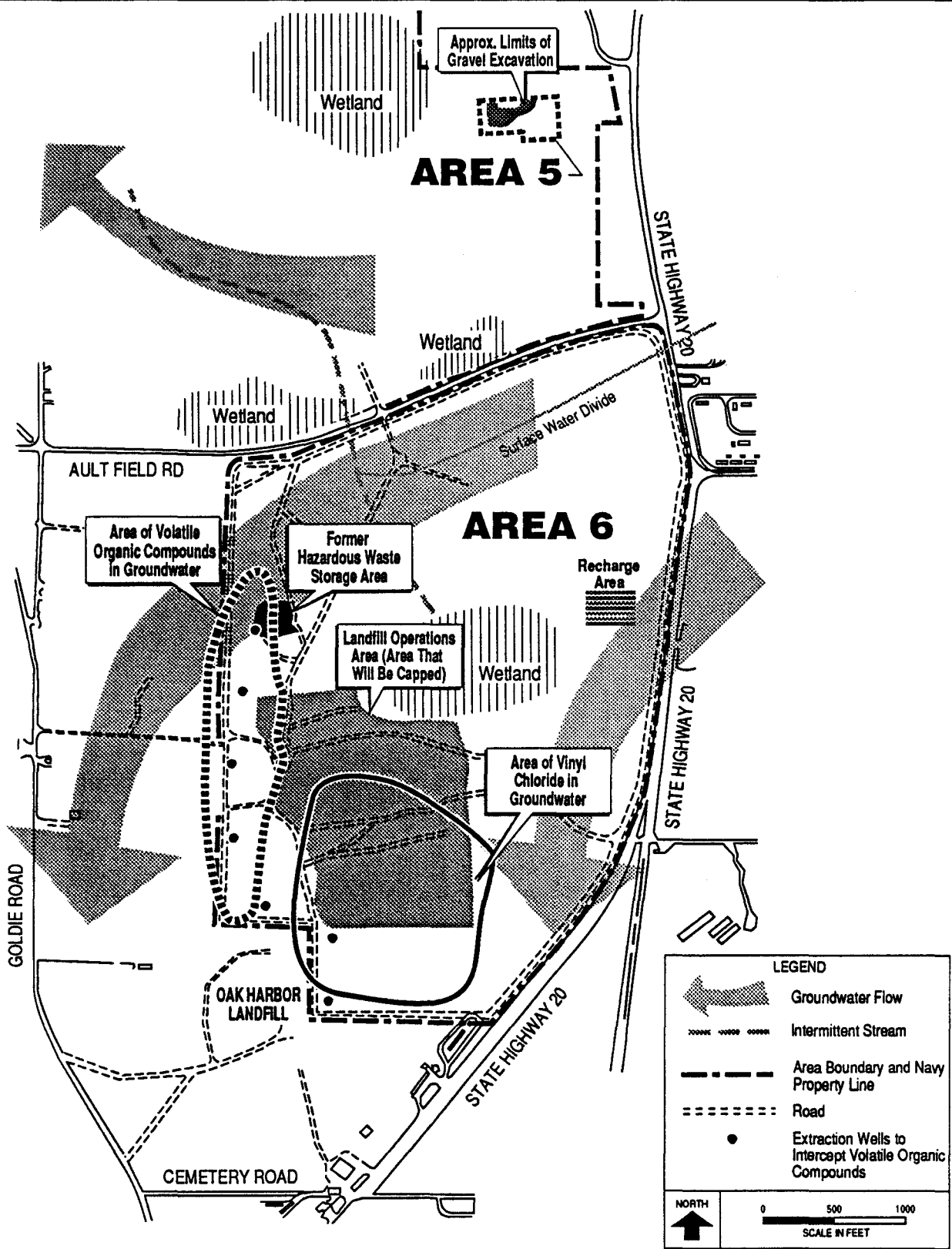

Figure 2
 Site Map
 Areas 5 and 6

Area 5 is currently a flat open area covered by a mixture of soil, gravel, and vegetation. Surface water flows to the southwest and southeast. Groundwater flows to the west and north. Approximately 600 feet west of Area 5 is a small freshwater wetland that historically received surface water runoff from the excavation area via a small gully extending west from the northwest edge of the excavation area. Because of the runoff from the excavation area to the western wetland, the area of investigation for Area 5 was enlarged to include surface water and sediments in the vicinity of the wetland. This enabled the investigation to determine whether the suspected landfill within the excavation area released contaminants to the wetlands.

2.2 Area 6—Landfill Operations Area and Former Hazardous Waste Storage Area

Area 6 is a 260-acre tract in the southeast corner of Ault Field. Within Area 6, there are two areas where wastes are known to have been disposed of. Hazardous wastes were disposed of at the former hazardous waste storage area (Figure 2) at a time when regulatory requirements had not been established. These wastes reportedly consisted of solvents, oily sludges, thinners, and other hazardous compounds. Hazardous waste disposal began in 1969 and ended in the early 1980s. The former hazardous waste storage area is approximately 15 feet by 40 feet. During operation, it was a pit approximately 10 feet deep. It has been filled and is now covered with natural vegetation.

A separate portion of Area 6 was used for Navy household municipal waste from 1969 to 1992, and is currently accepting construction debris and yard waste. This landfill operations area is approximately 40 acres and is now covered with soil and natural vegetation.

Area 6 is bordered by Ault Field Road to the north, State Highway 20 to the east, and the Oak Harbor Landfill on the south and southwest boundaries. Privately owned forested or logged land is located immediately west of Area 6. The Auld Holland Inn and a mobile home park are located off base at the southern boundary of the landfill property. Private residences are located to the east, west, and south of the Area 6 landfill.

Groundwater at Area 6 flows generally south. Because there is a groundwater divide approximately at Ault Field Road, the groundwater at Area 6 flows in a different direction than groundwater at Area 5. Currently, Area 6 surface water drains under Ault Field Road into the runway ditch drainage complex.

3.0 SITE HISTORY AND ENFORCEMENT ACTIVITIES

3.1 Site History

NAS Whidbey Island was commissioned September 21, 1942. The station was placed on reduced operating status at the end of the war. In December 1949, a continuing program to increase the capabilities of the air station was begun. The station's current mission is to maintain and operate Navy aircraft and aviation facilities and to provide associated support activities. Since the 1940s, operations at NAS Whidbey Island have generated a variety of hazardous wastes. These wastes were disposed of prior to the establishment of regulatory requirements, using disposal practices that were considered acceptable at that time.

In response to the requirements of CERCLA, the United States Department of Defense (DoD) established the Installation Restoration (IR) Program. The Navy, in turn, established a Navy IR program to meet the requirements of CERCLA and the DoD IR Program. From 1980 until early 1987, this program was called the Navy Assessment and Control of Installation Pollutants (NACIP) program. A set of procedures and terminologies were developed under this program to describe the NACIP activities, which were different from those used by the EPA in the administration of CERCLA. As a result of the implementation of SARA, the Navy has dropped NACIP and adopted the EPA CERCLA/SARA procedures and terminology.

Responsibility for the implementation and administration of the IR program has been assigned to the Navy Facilities Engineering Command (NAVFACENGCOM). The Southwest Division of NAVFACENGCOM has responsibility for the western states. Engineering Field Activity, Northwest (EFA Northwest) has responsibility for investigations of NAS Whidbey Island and other naval installations in the Pacific Northwest and Alaska.

In February 1990, NAS Whidbey Island's Ault Field was listed as a Superfund site on the EPA's National Priorities List (NPL). As a result of the listing, pursuant to a Federal Facilities Agreement (FFA) signed by the Navy, EPA, and Ecology in September 1990, the Navy conducted a Remedial Investigation/Feasibility Study (RI/FS) to determine the nature and extent of soil and groundwater contamination and to evaluate alternatives for the cleanup of contaminated areas.

3.2 Previous Investigations at NAS Whidbey Island

The Navy conducted an Initial Assessment Study (IAS) at NAS Whidbey Island under the NACIP program in 1984. A more focused follow-up investigation and report, NAS Whidbey Island Current Situation Report (CSR), was completed in January 1988. After the CSR was completed, further investigations were proposed for areas where

contamination was verified and where unverified conditions indicated further investigations were appropriate.

While the CSR was being prepared, EPA Region 10 performed preliminary assessments at NAS Whidbey Island, Ault Field, to evaluate risks to public health and the environment using the Hazard Ranking System (HRS).

In late 1985, the EPA proposed that Ault Field be nominated for the NPL. In February 1990, the site was officially listed on the NPL. EPA's inclusion of Ault Field on the NPL was based on the number of waste disposal and spill sites discovered, types and quantities of hazardous constituents (such as petroleum products, solvents, paints, thinners, jet fuel, pesticides, and other wastes), and the potential for domestic wells and local shellfish beds to be affected by wastes originating from the site.

In the summer of 1989, prior to beginning remedial investigation field efforts, an accelerated Initial Investigation of Area 6 was performed. The investigation at Area 6 assessed whether groundwater contamination was present and if water supply wells in the vicinity were or could be affected. Whereas groundwater contamination was confirmed, the investigation determined that local water supply wells were unaffected. However, the potential for future impacts on the water supply wells did exist. Based on the Initial Investigation, an action plan for the RI/FS was developed in 1990.

In 1989, as part of a statewide program to monitor the quality of drinking water supplies, the Washington State Department of Health (DOH) tested 13 public wells located within a 1-mile radius of Area 6 and the Oak Harbor Landfill. No organic compounds were found. Results indicated that the drinking water supplies were unaffected.

In early 1991, during the RI/FS investigation, groundwater sampling results indicated that vinyl chloride concentrations in on-site monitoring wells exceeded maximum contaminant levels (MCLs) for drinking water and that contamination may be migrating off site. As a result, in May 1991, the Navy called upon the DOH to sample one public and six private wells in the vicinity of Area 6. The seven wells are located to the south, east, and southwest of the current landfill boundary. No evidence of contamination from Area 6 was detected in these wells. Nevertheless, as a precautionary measure, the Navy began a program of voluntary water hookups to the public water supply system for landowners who were potentially affected.

In response to continued concerns about the migration of volatile organic compounds in groundwater, an interim action ROD was signed by the Navy, EPA, and Ecology in April 1992. This interim action committed the Navy to construct a groundwater extraction and treatment system at Area 6 to halt the migration of volatile organic compounds from the former hazardous waste storage area. This system is currently under construction and is scheduled to begin operation in the spring of 1994.

Concerns about possible off-site groundwater contamination also resulted in resampling of private wells in December 1992. Although no volatile organic compounds were detected in private wells adjacent to the landfill, the Navy is continuing to provide connections to an alternate water supply to owners of private wells in the vicinity of Area 6.

4.0 COMMUNITY RELATIONS

The specific requirements for public participation pursuant to CERCLA Section 117(a), as amended by SARA, include releasing the Proposed Plan to the public. For the interim action, the Proposed Plan was issued on January 3, 1992, and the public meeting was held on January 27, 1992. Landowners included in the water hookup program were sent special mailings informing them of the interim action Proposed Plan. For the final action, the Proposed Plan was issued on June 24, 1993. The public comment period on the final proposed remedial action was extended from July 23, 1993, to August 25, 1993. A public meeting was held July 14, 1993. Approximately 30 comments were received on the Proposed Plan for final remedial action. Responses to these comments are included in this ROD as Appendix A.

In addition to the public meeting, EPA sponsored a public information session on August 25, 1993, to provide more technical details about the remedial investigations at OU 1 and to discuss the rationale for the Navy's proposed actions. As a result of these public comments, some changes to the Proposed Plan have been made and are incorporated into this ROD.

Documents pertaining to both the interim and final actions were placed in the following information repositories:

Oak Harbor Library
7030 70th N.E.
Oak Harbor, Washington 98277
Phone: (206) 675-5115

NAS Whidbey Island Library (for individuals with base access)
1115 W. Lexington St.
Oak Harbor, Washington 98278-2700
Phone: (206) 257-2702

Sno-Isle Regional Library System
Coupeville Library
788 N.W. Alexander
Coupeville, Washington 98239
Phone: (206) 678-4911

The Administrative Record (see Appendix B for an index) is on file at the following location:

Engineering Field Activity Northwest
Naval Facilities Engineering Command
1040 N.E. Hostmark Street
Olympic Place 2
Poulsbo, Washington 98370
Phone: (206) 396-5984

Community relations activities have established communication between the citizens living near the site, the Navy, EPA, and Ecology. Two citizens are members of the technical review committee and have received copies of all draft documents for review. The actions taken to satisfy the statutory requirements also provided a forum for citizen involvement and input to the Proposed Plan and ROD.

Community relations activities at the site include the following:

- Creation of a community relations plan
- Technical review committee meetings with representatives from the public and other governmental agencies
- Meetings with nearby property owners to discuss the water hookup program
- Issuance of the interim action and final action Proposed Plan in fact sheet format to facilitate discussion
- Newspaper advertisement for the Proposed Plan
- Future public meetings to present information related to the remedial activities at the site

5.0 SCOPE AND ROLE OF RESPONSE ACTION WITHIN SITE STRATEGY

Potential source areas at NAS Whidbey Island, Ault Field, have been grouped into separate OUs, for which different schedules have been established. OU 1 is the first OU at NAS Whidbey Island, Ault Field, for which a final cleanup action has been selected. Cleanup actions will be selected in late 1993 for OU 4 (Seaplane Base) and in 1994 for OUs 2, 3, and 5 (Ault Field).

The cleanup actions for OU 1 described in this ROD address on-site groundwater contamination and source areas associated with surface disposal at the former hazardous waste storage area and landfill operations area in Area 6. A groundwater extraction and treatment action is being initiated at this site as a result of the interim action ROD. The groundwater cleanup actions described in this ROD are consistent with and will expand upon the previously selected groundwater treatment system. Actions for Area 5 are limited to monitoring groundwater for metals using low-flow sampling methods. The cleanup actions described in this ROD address all known current and potential risks to human health and the environment associated with the OU 1 site.

6.0 SUMMARY OF SITE CHARACTERISTICS

OU 1 borders the northeast boundary of the city of Oak Harbor. Oak Harbor is the regional center for north Whidbey Island. The current population of Oak Harbor is approximately 14,000. Land use in the vicinity of OU 1 is primarily residential, small commercial, and open forested or logged tracts. A mobile home park and Auld Holland Inn are located at the southern boundary of Area 6. The Ault Field runways are approximately 1½ miles northeast of Areas 5 and 6. No historical or archaeological resources are located within the OU 1 boundaries. In addition, the site is not within a 100-year floodplain. Bald eagles have been sighted in the vicinity of OU 1.

6.1 Geology and Hydrogeology

NAS Whidbey Island, Ault Field, like most of Whidbey Island, is covered with a thick sequence of Vashon glacial deposits laid down during the Vashon glaciation over 10,000 years ago. Groundwater generally occurs within a series of aquifers, composed of permeable sand and gravel layers deposited by glacial meltwater, separated by finer-grained glacial silt and clay deposits and interglacial fluvial deposits. The sequence of glacial and interglacial strata beneath OU 1 is shown on the geologic cross section of the former hazardous waste storage area developed from samples taken during drilling and well installation during the OU 1 investigation (Figure 3).

Three principal water-bearing units occur beneath OU 1. These are designated the shallow, intermediate, and deep or sea level aquifers. Localized perched aquifers also

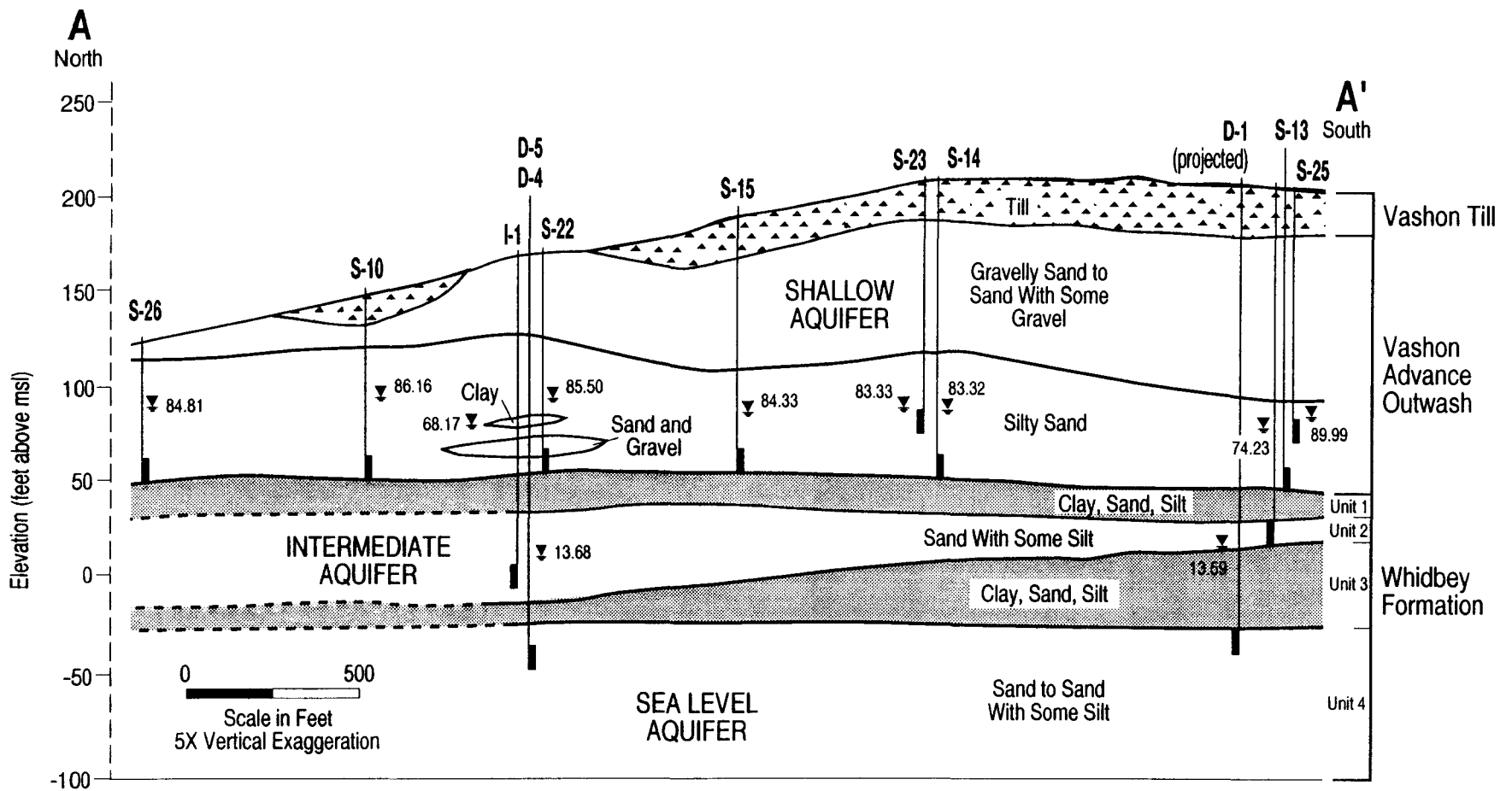

Figure 3
Geologic Cross Section A-A'

occur above the glacial till in portions of Area 6. Hydrogeologically, the subsurface materials have been locally characterized into six units. These units are Vashon Till, Vashon Advance Outwash, and four subunits of the Whidbey Formation.

The shallow aquifer is contained primarily within the lower Advance Outwash sediments, deposited by meltwater ahead of the advancing glacier. This is an unconfined aquifer with water levels ranging from about 77 to 92 feet above sea level or 20 to 145 feet below the ground surface, depending on the relative elevations of the water table and the land surface. This unit is separated from the underlying intermediate aquifer by the fine sands, silts, and clays of the upper Whidbey (Unit 1) Formation.

The groundwater flow direction within the shallow aquifer is generally north to south across Area 6. Groundwater flow beneath Area 5 is generally to the west (Figure 2). The average groundwater gradient is approximately 0.0025 foot per foot; estimated groundwater velocities, a function of both gradient and permeability, range from about 92 to 456 feet per year within the shallow aquifer beneath OU 1.

The intermediate aquifer occupies the sandier middle portion (Unit 2) of the Whidbey Formation. This water-bearing unit is moderately continuous and is generally confined by overlying low-permeability sediments. The top of this unit occurs at about 20 feet above sea level; water levels beneath Area 6 range from about 68 to 76 feet above sea level. Groundwater within the intermediate aquifer generally flows in a southeasterly direction at an estimated velocity of 8 to 27 feet per year. This unit is separated from the underlying deep aquifer by the low-permeability silts and clays of the Whidbey Unit 3 aquitard.

The deep aquifer, also known as the sea level aquifer, is a nearly continuous, confined water-bearing unit within the bottom (Unit 4) of the Whidbey Formation. The top of the unit occurs approximately 20 feet below sea level; potentiometric levels in this unit beneath Area 6 are at about 15 feet above sea level or 160 to 200 feet below ground surface, depending on the land surface elevation. The groundwater within this unit appears to flow radially from an area north of Ault Field Road to the south and southwest. The gradient across the site is very slight, resulting in an estimated velocity of 0.04 to 5 feet per year.

The three aquifers are separated by relatively impermeable confining layers and are hydrogeologically distinct. Pumping tests reveal no measurable effect on wells in the shallow aquifer from pumping in adjacent deep aquifer wells. Progressively deepening water levels in each aquifer, however, suggest minor downward leakage between aquifers.

6.2 Nature and Extent of Contamination

The former hazardous waste storage area was at one time a source of volatile organic compounds within Area 6. The landfill operations continue to be a source of volatile organic compounds at the site. The source of elevated manganese in Area 5 groundwater is unknown; it may be attributable to background conditions. Sampling locations are illustrated in Figures 4 and 5.

6.2.1 Calculation of Background Metals Concentrations

Various wells were selected to measure background levels of metals concentrations. The background wells selected were existing wells upgradient from the OU 1 sources (former hazardous waste storage area and landfill operations area). Separate background concentrations were calculated for each of the three aquifers. The aquifers are clearly identifiable as separate, with different piezometric surfaces, gradients, and water chemistry.

Wells selected in the vicinity of OU 1 included drinking water wells and Area 6 monitoring wells. Results from Phase 3 sampling in December 1992 were used, because this sampling was accomplished with a low-flow sampling technique that resulted in low turbidity samples, which are more representative of groundwater quality. Background calculations were based on Ecology's July 1992 guidance for calculation of background values. Metals background values for each aquifer are included in tables in Sections 6.2.2 and 6.2.3.

6.2.2 Area 5 Shallow Aquifer

Six monitoring wells were installed in the shallow aquifer for the Area 5 investigation. These wells were sampled three times:

- Interim Action (June 1990)
- Phase 1 (December 1990 to May 1991)
- Phase 2 (July 1991 to October 1991)

Shallow groundwater in Area 5 had low concentrations of relatively few contaminants (Table 1). Volatile organic compounds (trichloroethene, 1,1-dichloroethene) were detected at low levels bordering on the detection limit and less than regulatory screening criteria; no semivolatile organics or pesticides were detected. The compound 1,1-dichloroethene was detected in only one well (N5-16) in Area 5, at a concentration of 0.46 micrograms per liter ($\mu\text{g/L}$), which exceeds the State of Washington Model Toxics Control Act (MTCA) risk-based values. The single detected value at that well was from the Phase 2 sampling event. The compound 1,1-dichloroethene was not detected in the

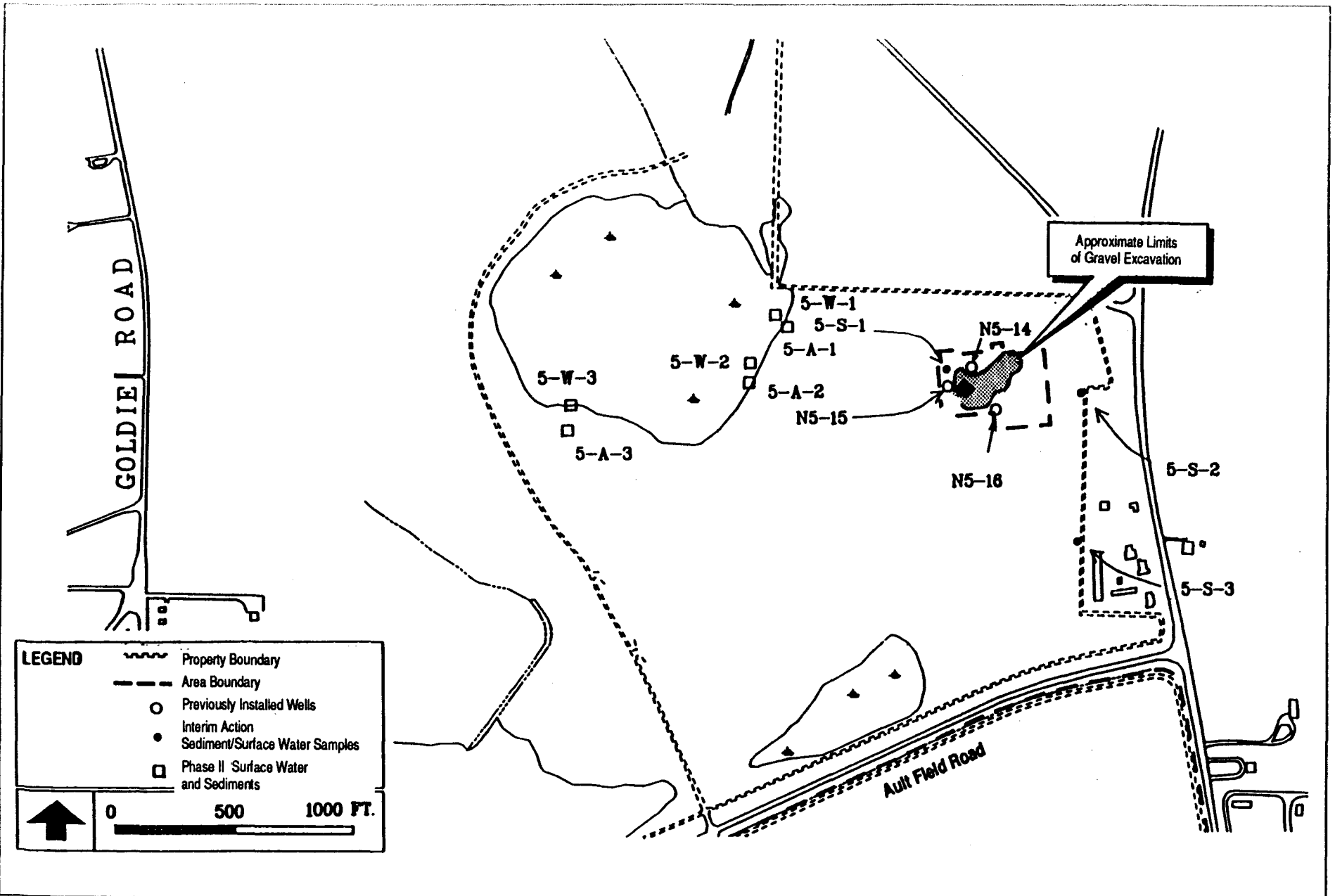
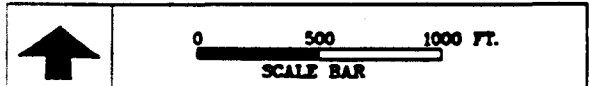
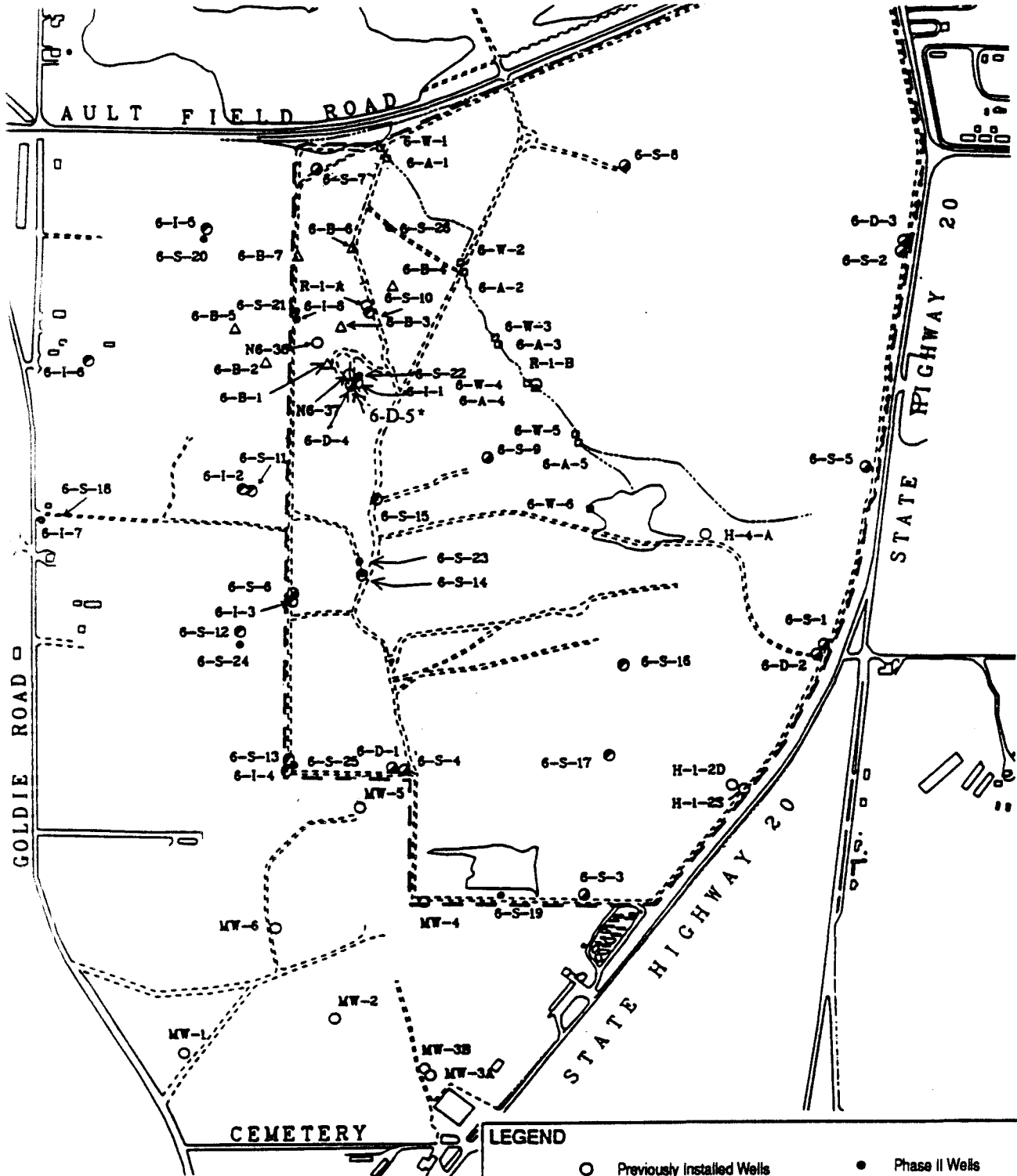

Figure 4
Area 5 Sampling Locations



LEGEND	
○	Previously Installed Wells
◻	Interim Action Sediment/Surface Water Samples
●	Initial Investigation Wells
⊙	Phase I Wells
●	Phase II Wells
△	Phase II Borings
■	Phase I Surface Water Samples
*	Phase III Well

CLEAN
 COMPREHENSIVE LONG-TERM ENVIRONMENTAL ACTION NAVY

Figure 5
Area 6 Sampling Locations

CTO 0005
 OPERABLE UNIT 1
 NAS WHIDBEY, WA
 ROD

Table 1
Summary of Shallow Aquifer Groundwater Sampling Results for Area 5

Analyte	Background Value (µg/L)	Range of Concentration (µg/L)	Frequency of Detection	Range of Detection Limits
V-CLP				
1,1-Dichloroethene	BDL	0.46	1/6	0.20 - 10.00U
Trichloroethene	BDL	0.43	1/6	0.20 - 10.00U
Metals				
Aluminum	100	429 - 74,900	9/9	NA
Arsenic	8.4	2.9 - 16.5	3/3	2 - 4.1U
Barium	50	27.3 - 121	3/4	39UJ
Cadmium	1	3.20	1/6	3U
Calcium	32,724.6	18,100 - 42,200	9/9	NA
Copper	100	10.8 - 37.2	2/6	15.2UJ
Iron	1,009.8	534 - 143,000	8/8	NA
Lead	4.1	8.9 - 29.9	3/5	3.6 - 14.9U
Magnesium	28,786.3	22,100 - 67,500	8/8	NA
Manganese	118.6	58 - 5,000	8/8	NA
Nickel	24.4	40.70	1/5	17 - 36U
Potassium	5,020	1,810 - 8,460	5/6	4,130U
Sodium	28,414.9	10,500 - 18,900	8/8	NA
Vanadium	10	11 - 246	4/7	6U
Zinc	100	268 - 2,410	4/8	28 - 73U

Notes:

µg/L - micrograms per liter

V-CLP - volatiles analysis—Contract Laboratory Program

BDL - below detection limit

U - not detected

NA - not applicable

UJ - not detected above the reported sample quantitation limit

Metals results are from bailed samples (high turbidity).

prior two sampling events at that well. Trichloroethene was detected at well N5-14 at a concentration of 0.43 $\mu\text{g}/\text{L}$.

Some metals were detected above background concentrations in Area 5 groundwater. Sampling results from Area 6 using low-flow sampling techniques resulted in low or nondetected concentrations of metals. Therefore, historical metals results at Area 6 are likely attributable to suspended particulates. A similar reduction of metal concentrations at Area 5 is expected. However, manganese concentrations at Area 5 appear to be elevated relative to background concentrations. The source of elevated manganese is unknown.

6.2.3 Area 6 Shallow Aquifer

For the Area 6 investigation, 28 monitoring wells were installed in the shallow aquifer. In addition, three wells were sampled in the Oak Harbor Landfill, which is adjacent to Area 6. Many of the Area 6 wells were sampled six times:

- Initial Investigation (October 1989)
- Interim Action (June 1990)
- Phase 1 (December 1990 to May 1991)
- Rapid Response (July 1991 to August 1991)
- Phase 2 (July 1991 to October 1991)
- Phase 3 (December 1992)

Table 2 summarizes groundwater sampling results for Area 6. In the Area 6 shallow groundwater, volatile organic compounds were identified in two distinct plumes. In the shallow aquifer underlying the northern part of the landfill and near the former hazardous waste storage area, six volatile organic compounds (1,1,1-trichloroethane, trichloroethene, 1,1-dichloroethane, 1,2-dichloroethene, 1,1-dichloroethene, and carbon tetrachloride) were detected at concentrations exceeding federal and state risk-based screening levels. Maximum concentrations of these organic compounds occur in shallow wells N6-38 and N6-37, 250 feet apart, in the northern part of the landfill and within the former hazardous waste storage area. The second plume is vinyl chloride at the southern part of the landfill. The vinyl chloride present may be a degradation product of trichloroethene and 1,1,1-trichloroethane or it may be a result of landfill debris composition. The presence of these chemicals at the southern border of Area 6 may mark the lateral extent of this plume.

No direct evidence of dense nonaqueous phase liquid (DNAPL) has been found in either soil or groundwater in Area 6. However, levels of trichloroethane in N6-38 have been as high as 32,000 $\mu\text{g}/\text{L}$, approximately 1 percent of pure phase solubility. Levels of trichloroethene have approached nearly 0.5 percent effective pure phase solubility in N6-37 (1,800 $\mu\text{g}/\text{L}$). These levels suggest that nonaqueous phase liquids (NAPL) may be

Table 2
Summary of Area 6 Groundwater Sampling Results

Analyte	Aquifer	Background Value (µg/L)	Range of Concentration (µg/L)	Frequency of Detection	Range of Detection Limits (µg/L)
V-CLP					
1,1,1-Trichloroethane	Shallow	BDL	3 - 32,000	31/82	10.00U - 13.00U
1,1-Dichloroethane	Shallow	BDL	0.79 - 26	18/80	0.20 - 10.00U
1,1-Dichloroethene	Shallow	BDL	0.43 - 1,900	23/80	0.20 - 10.00U
1,2-Dichloroethene	Shallow	BDL	11 - 630	15/81	0.20 - 10.00U
Trichloroethene	Shallow	BDL	0.51 - 1,800	22/80	0.20 - 250U
Vinyl chloride	Shallow	BDL	1.98 - 53.50	10/77	0.20 - 250U
Metals (Phase 3 Data Only)					
Aluminum	Shallow	100	40.1 - 412	14/18	34 - 59U
Arsenic	Shallow	8.4	2.1 - 13.5	11/18	2 - 3U
Barium	Shallow	50	8.3 - 84.6	17/18	9 - 9U
Calcium	Shallow	32,724.6	12,300 - 127,000	18/18	NA
Chromium	Shallow	20	7.6 - 188	10/18	4 - 6U
Copper	Shallow	100	2.1 - 9.7	7/18	2 - 5U
Iron	Shallow	1,009.8	23.1 - 12,100	18/18	NA
Lead	Shallow	4.1	1 - 1.6	6/18	1 - 2U
Magnesium	Shallow	28,786.3	10,600 - 37,800	18/18	NA
Manganese	Shallow	118.6	3.3 - 1,790	18/18	NA
Nickel	Shallow	24.4	10.9 - 93.1	9/18	6 - 15U
Potassium	Shallow	5,020	1,440 - 6,010	18/18	NA
Sodium	Shallow	28,414.9	10,700 - 40,300	18/18	NA
Vanadium	Shallow	10	4.1 - 9.3	10/18	4 - 6U
Zinc	Shallow	100	3.9 - 33.7	17/18	2 - 2U

Table 2 (Continued)
Summary of Area 6 Groundwater Sampling Results

Analyte	Aquifer	Background Value (µg/L)	Range of Concentration (µg/L)	Frequency of Detection	Range of Detection Limits (µg/L)
V:CLP					
1,1,1-Trichloroethane	Intermediate	BDL	5 - 5	1/17	0.20 - 10.00U
Trichloroethene	Intermediate	BDL	0.99 - 1.7	3/19	0.20 - 10.00U
Vinyl chloride	Intermediate	BDL	0.72 - 3.35	2/18	0.20 - 10.00U
Metals					
Aluminum	Intermediate	100	68.2 - 460	7/8	59U
Arsenic	Intermediate	36.8	7 - 61.2	8/8	NA
Barium	Intermediate	83.6	15.6 - 68.7	8/8	NA
Calcium	Intermediate	50,613.2	24,800 - 53,700	8/8	NA
Chromium	Intermediate	5	4.1 - 4.1	1/8	4 - 6U
Iron	Intermediate	885.6	69 - 2,080	8/8	NA
Lead	Intermediate	1	1 - 1.3	4/8	1 - 2U
Magnesium	Intermediate	25,645.7	10,400 - 22,100	8/8	NA
Manganese	Intermediate	333.4	47 - 1,170	8/8	NA
Potassium	Intermediate	6,725.4	4,230 - 6,610	8/8	NA
Sodium	Intermediate	36,140.3	17,400 - 23,500	8/8	NA
Zinc	Intermediate	100	2.6 - 19.4	5/8	2U

Table 2 (Continued)
Summary of Area 6 Groundwater Sampling Results

Analyte	Aquifer	Background Value ($\mu\text{g/L}$)	Range of Concentration ($\mu\text{g/L}$)	Frequency of Detection	Range of Detection Limits ($\mu\text{g/L}$)
V-CLP					
1,1-Dichloroethene	Deep	BDL	0.43	1/11	0.2 - 10.00U
Trichloroethene	Deep	BDL	0.87	2/11	0.2 - 10.00U
Metals					
Aluminum	Deep	66.9	35.3 - 183	4/5	59U
Arsenic	Deep	109	22.1 - 89.1	5/5	NA
Barium	Deep	83.1	30.8 - 112	5/5	NA
Calcium	Deep	52,700	19,100 - 52,700	5/5	NA
Iron	Deep	770	67.2 - 1,180	5/5	NA
Magnesium	Deep	22,100	5,250 - 22,100	5/5	NA
Manganese	Deep	494	86.9 - 499	5/5	NA
Potassium	Deep	9,970	4,220 - 9,970	5/5	NA
Sodium	Deep	21,400	16,600 - 26,600	5/5	NA
Vanadium	Deep	10	6.5	1/5	4 - 6U
Zinc	Deep	100	4.7 - 8.1	2/5	1 - 2U

Notes:

 $\mu\text{g/L}$ - micrograms per liter

V-CLP - volatiles analysis—Contract Laboratory Program

BDL - below detection limit

U - not detected

NA - not applicable

present in aquifer materials at or near the water table beneath the former hazardous waste storage area. Levels in 6-S-10 to the north of the former hazardous waste storage area increased dramatically from not detected to 1,100 $\mu\text{g}/\text{L}$ over three sampling events during the RI. Because 6-S-10 is screened at the bottom of the shallow aquifer and is located upgradient from the former hazardous waste storage area, this may also indicate DNAPL movement.

In a single sampling event, heptachlor, a chlorinated pesticide, was detected in groundwater at well 6-S-19. However, because the detection was an isolated event and because heptachlor was not detected in other wells, it is not considered a candidate for remediation. An herbicide, 2-methyl-4-chlorophenoxyacetic acid (MCPA), was reported in two groundwater samples (6-S-4 and 6-S-9).

A volatile organic plume extends to the southwest corner of Area 6. Volatile contaminants migrate in the direction of groundwater flow and also vertically in the shallow aquifer. The fact that maximum concentrations of volatile compounds of concern are found in the groundwater under the former hazardous waste storage area implies that the sources of volatile organics were likely to be from disposal, spills, and leaks of solvents previously stored in the former hazardous waste storage area. Solvents have been neither disposed of nor stored at this location since the late 1970s. Figure 2 illustrates both the plume of volatile organic compounds and vinyl chloride in the shallow aquifer.

Four inorganic analytes (arsenic, chromium, lead, and manganese) were detected above background in the shallow groundwater.

6.2.4 Intermediate Aquifer

Eight wells were installed in the intermediate aquifer in Area 6. In addition, an intermediate aquifer well in the Oak Harbor Landfill was sampled. The compounds 1,1,1-trichloroethane, toluene, and trichloroethene were detected on site along the western boundary at concentrations less than federal or state screening criteria. Manganese concentrations exceeded background in half of the intermediate aquifer wells. Vinyl chloride was detected in one off-site well located west of the western boundary. Vinyl chloride was not detected in any of the on-site intermediate aquifer wells; therefore, Area 6 does not appear to be the source. Arsenic concentrations exceeded background in one well. No semivolatile organic compounds, pesticides, or herbicides were detected in the intermediate aquifer.

6.2.5 Deep Aquifer

Five deep aquifer wells in Area 6 were sampled. One is designated as a background well (6-D-3). The samples from these wells indicate that the deep aquifer has not been

contaminated by OU 1 site operations. During the sampling of well 6-D-4, some contamination was identified in the well. A video survey of well 6-D-4 revealed that two well-casing joints were leaking within the saturated zone of the shallow aquifer. Because of this observation and because no contamination was found in this well in sampling done in 1989 and in 1990, it is likely that volatile organic compounds found in this well do not represent the deep aquifer and are a result of a leak in the well casing. Well 6-D-4 was pumped, properly abandoned, and replaced by well 6-D-5. No volatile organic compounds were detected in well 6-D-5, located slightly upgradient from well 6-D-4. Samples analyzed from well 6-D-4 after pumping and before well abandonment indicate no detected concentrations of volatile organic compounds.

6.2.6 Surface Water

Surface water data are summarized in Table 3.

Area 5. Three surface water samples from the wetland areas in the Area 5 investigation area were sampled and analyzed in March 1991. Three volatile organic compounds (trichloroethene, 1,1-dichloroethane, and 1,1-dichloroethene) and several inorganic analytes were detected in Area 5 surface water samples. None of the volatile organics exceeded levels specified by EPA's Ambient Water Quality Criteria (AWQC) to protect aquatic organisms. Five inorganic analytes exceeded AWQC standards: zinc, lead, copper, cadmium, and silver.

Area 6. In Area 6, six surface water samples were collected from the intermittent stream in February 1991. Trichloroethene was detected at a concentration less than that specified by EPA's AWQC to protect aquatic organisms. Four inorganic analytes exceeded AWQC standards: arsenic, chromium, manganese, and zinc.

6.2.7 Sediments

Sediment data are summarized in Table 4.

Area 5. Three sediment samples were collected from the wetlands adjacent to Area 5 in June 1990 and again from approximately the same locations in February 1991. Several inorganic analytes and nine pesticides (heptachlor epoxide, dieldrin, 4,4'-dichlorodiphenyl dichloroethene [4,4'-DDE], 4,4'-dichlorodiphenyl trichloroethane [4,4'-DDT], alpha-chlordane, gamma-chlordane, endosulfan, endrin, and MCPA) were detected in the wetland sediments. Pesticide results were inconsistent between the two sampling events. Although pesticides were detected in both the 1990 and 1991 sampling events, no individual pesticide compound was common to both events. State sediment quality guidelines were exceeded for six metals and two pesticides in Area 5 (arsenic, chromium, copper, iron, manganese, nickel, endrin, and 4-4'-DDT).

Table 3
Surface Water Data for Areas 5 and 6

Compound/Analyte	Area 5			Area 6		
	Range of Concentration	Frequency of Concentration	Range of Detection Limits	Range of Concentration	Frequency of Concentration	Range of Detection Limits
Volatiles (µg/L)						
1,1-Dichloroethane	4.3 - 48	3/3	1 - 5U	NA	0/6	NA
1,1-Dichloroethene	4.9 - 21.7	2/3	1 - 3 U	NA	0/6	NA
Trichloroethene	2.6 - 3.4	2/3	1 - 10U	4.23	1/6	1 - 5U
Inorganics (µg/L)						
Aluminum	155 - 1,365	3/3	NA	475 - 33,600	6/6	NA
Antimony	NA	NA	NA	38.6 - 39.2	2/6	35U
Arsenic	NA	0/3	NA	3 - 15.2	4/6	3U
Barium	29.1 - 29.2	2/3	26U	50 - 61.8	2/6	NA
Cadmium	2.15 - 2.2	2/3	2U	2.6	1/6	NA
Calcium	6,058 - 18,600	3/3	NA	5,820 - 25,800	6/6	NA
Chromium	8.2	1/3	NA	4 - 83.1	5/6	4U
Cobalt	NA	0/3	NA	30.1	1/6	17U
Copper	14	1/3	NA	6.5 - 47	5/6	NA
Iron	313 - 951	3/3	NA	6,830 - 9,520	2/6	NA
Lead	1.5 - 2.5	2/3	1U	1.5 - 33.55	5/6	1U
Magnesium	3,460 - 14,200	3/3	NA	6,342 - 32,600	6/6	NA
Manganese	51.5 - 447.5	3/3	NA	57 - 1,320	6/6	NA
Nickel	14.1 - 19.7	2/3	9U	11.6 - 223	5/6	9U
Potassium	1,738 - 7,185	2/3	NA	1,840 - 6,810	6/6	NA
Silver	5.1	1/3	4U	NA	0/6	NA
Sodium	7,775 - 27,589	3/3	NA	7,750 - 12,150	6/6	NA
Vanadium	NA	0/3	NA	605 - 76	5/6	NA
Zinc	13 - 48	2/3	33.5 - 186U	19 - 119	5/6	14.25 - 17U

Table 3 (Continued)
Surface Water Data for Areas 5 and 6

Compound/Analyte	Area 5			Area 6		
	Range of Concentration	Frequency of Concentration	Range of Detection Limits	Range of Concentration	Frequency of Concentration	Range of Detection Limits
Pesticides ($\mu\text{g/L}$)						
Dieldrin	NA	0/3	NA	1.7	1/5	8.7 - 12U
Endrin	NA	0/3	NA	1.3	1/5	8.7 - 25U
MCPA	NA	0/3	NA	2,500 - 2,700	2/5	77U

Notes:

 $\mu\text{g/L}$ - micrograms per liter

NA - not applicable

U - not detected

MCPA - 2-methyl-4-chlorophenoxyacetic acid

Table 4
Sediment Data for Areas 5 and 6

Compound/Analyte	Area 5			Area 6		
	Range of Concentration	Frequency of Concentration	Range of Detection Limits	Range of Concentration	Frequency of Concentration	Range of Detection Limits
Inorganics (mg/kg)						
Aluminum	14,500 - 19,233	3/3	NA	4,060 - 17,050	5/5	NA
Arsenic	11.3	1/3	NA	3.7 - 9.3	5/5	NA
Barium	128	1/3	NA	22.6 - 113.5	5/5	NA
Beryllium	0.36	1/3	NA	NA	0/5	NA
Calcium	1,730 - 9,640	3/3	NA	2,270 - 3,985	5/5	NA
Chromium	62	1/3	NA	15.6 - 30.1	4/5	NA
Cobalt	26.4	1/3	NA	4 - 9.1	4/5	NA
Copper	NA	0/3	NA	7.5 - 43.7	5/5	NA
Iron	4,470 - 28,633	3/3	NA	7,970 - 19,500	5/5	NA
Lead	NA	0/3	NA	8.3 - 19.6	2/5	NA
Magnesium	1,460 - 23,300	3/3	NA	4,520 - 6,910	5/5	NA
Manganese	36.8 - 756	3/3	NA	118 - 306	5/5	NA
Nickel	148	1/3	NA	31.4 - 49.4	5/5	NA
Potassium	191 - 1,897	3/3	NA	313 - 1,060	5/5	NA
Sodium	334 - 336	2/3	NA	150 - 383	5/5	NA
Vanadium	16.9 - 53.8	3/3	NA	15.7 - 45.7	5/5	NA
Zinc	13.9 - 49	3/3	NA	NA	0/5	NA
Pesticides (µg/kg)						
Dieldrin	NA	0/3	NA	1.7	1/5	8.7 - 12U
Endrin	NA	0/3	NA	1.3	1/5	8.7 - 25U
MCPA	NA	0/3	NA	2,500 - 2,700	2/5	77U

Notes:

mg/kg - milligrams per kilogram

NA - not available

µg/kg - micrograms per kilogram

U - not detected

MCPA - 2-methyl-4-chlorophenoxyacetic acid

Area 6. Three sediment samples were collected in June 1990 and again from approximately the same locations in February 1991. Several inorganic analytes and six pesticides (aldrin, dieldrin, endosulfan, endrin, heptachlor epoxide, and MCPA) were detected in the sediments. Pesticide results were inconsistent between the two sampling results. State sediment quality guidelines were exceeded for four metals and two pesticides in Area 6 (arsenic, chromium, copper, nickel, heptachlor epoxide, and aldrin). No volatile or semivolatile organic compounds were detected.

6.2.8 Soil

Area 5. Soil samples were collected at the surface and at depths of 1 foot, 15 feet, and at the shallow aquifer screen zone during construction of three of the monitoring wells. Phenol was detected in the 15-foot sample at two of the locations. It was detected at the shallow aquifer screen zone in one sample. The highest concentration of phenol detected was 43 micrograms per kilogram ($\mu\text{g}/\text{kg}$). Barium, beryllium, and vanadium exceeded background soils concentrations.

Area 6. Soil samples were collected at the surface and at depths of 1 foot, 5 feet, 15 feet, and increasing at 5-foot intervals to 80 feet deep at some of the 39 soil boring locations at Area 6. Soils were sampled at the former hazardous waste storage area; at areas to the north, south, and west of the former hazardous waste storage area; and at the east side of the landfill operations area. Table 5 summarizes soils data for four locations (6-B-1, 6-B-3, 6-S-22, 6-I-1) at the former hazardous waste storage area. Relatively low concentrations of several volatile organic compounds were detected in the subsurface soils underlying the former hazardous waste storage area (Figure 6). All concentrations were below MTCA Method B values for groundwater protection (100 x groundwater cleanup level). These chemicals have most likely been washed by rainwater through the subsurface soils and into the shallow aquifer.

Table 6 summarizes soils data for all other Area 6 sampling locations. Volatile organic compounds were detected throughout these sampling areas but at concentrations at or near detection limits. No chlorinated pesticides, polychlorinated biphenyls, or organophosphorus pesticides were detected.

7.0 SUMMARY OF SITE RISKS

CERCLA response actions at OU 1 are intended to protect human health and the environment from risks related to possible current and future exposures to chemicals at the site.

The baseline risk assessment provides the basis for taking action and indicates the exposure pathways that need to be addressed by the remedial action. It serves as the

Table 5
Summary of Soil Sampling Results From Former Hazardous Waste Storage Area

Analyte	Background Value	Range of Concentration	Frequency of Detection	Range of Detection Limits
V-CLP (µg/kg)				
1,1,1-Trichloroethane	NA	2 - 49	14/48	2 - 12U
1,2-Dichloroethane	NA	5 - 32	1/48	5 - 12U
1,2-Dichloroethene	NA	8 - 32	3/48	5 - 12U
Trichloroethene	NA	2 - 40	16/48	10 - 12U
Methyl chloride	NA	5 - 200	2/48	10 - 12U
Metals (mg/kg)				
Aluminum	13,718	3,710 - 13,800	41/42	NA
Antimony	10.4	8.1 - 11.6	3/13	6.8 - 11.1U
Arsenic	4	0.6 - 4.6	30/33	1.1 - 3.2U
Barium	120	12.6 - 4,048	42/42	NA
Calcium	4,508	1,920 - 10,500	44/44	NA
Chromium	35	12.4 - 51.6	40/41	6.6 - 16.9U
Copper	18	6.3 - 43.9	35/38	8.9 - 13U
Iron	17,226	6,370 - 20,550	43/43	NA
Lead	17.8	0.84 - 63.1	19/19	NA
Magnesium	8,492	4,190 - 16,500	43/43	NA
Manganese	847	134 - 658	43/43	NA
Nickel	62.3	6 - 107	37/37	NA
Potassium	745	216 - 724	36/39	492 - 1,136U
Sodium	242	118 - 355	30/35	96 - 233U
Vanadium	37.7	10.7 - 206	43/43	NA
Zinc	49	15.9 - 57.1	33/34	23.4U

Table 5 (Continued)
Summary of Soil Sampling Results From Former Hazardous Waste Storage Area

Analyte	Background Value	Range of Concentration	Frequency of Detection	Range of Detection Limits
Polynuclear Aromatic Hydrocarbons (mg/kg)				
Anthracene	NA	150	1/20	NA
Benzo(a)anthracene	NA	220	1/20	NA
Benzo(b)fluoranthene	NA	210	1/20	NA
Benzo(k)fluoranthene	NA	190	1/20	NA
Benzo(g,h,i)perylene	NA	110	1/20	NA
Chrysene	NA	200	1/20	NA
Fluoranthene	NA	360	1/20	NA

Notes:

V-CLP - volatiles analysis—Contract Laboratory Program

 $\mu\text{g}/\text{kg}$ - micrograms per kilogram

NA - not applicable

U - not detected

 mg/kg - milligrams per kilogram

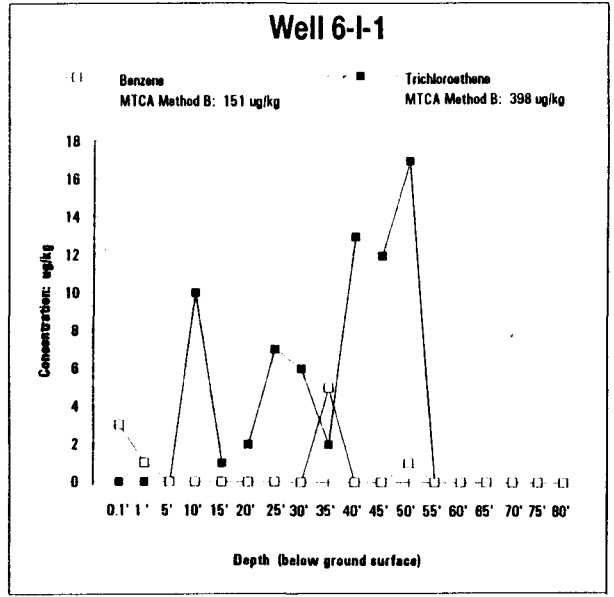
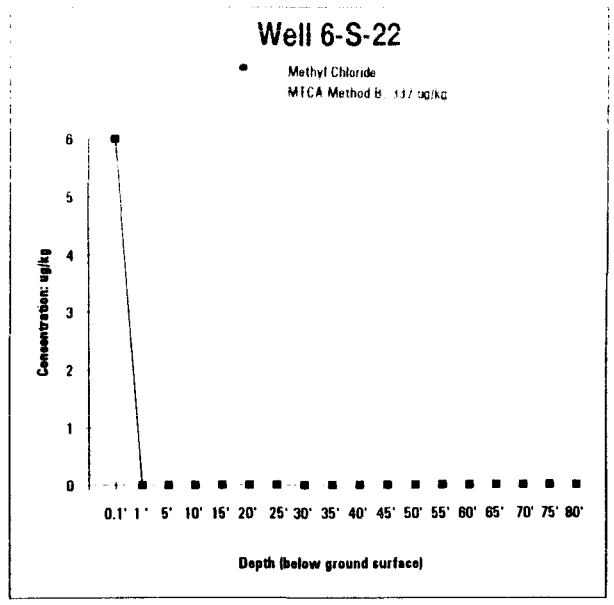
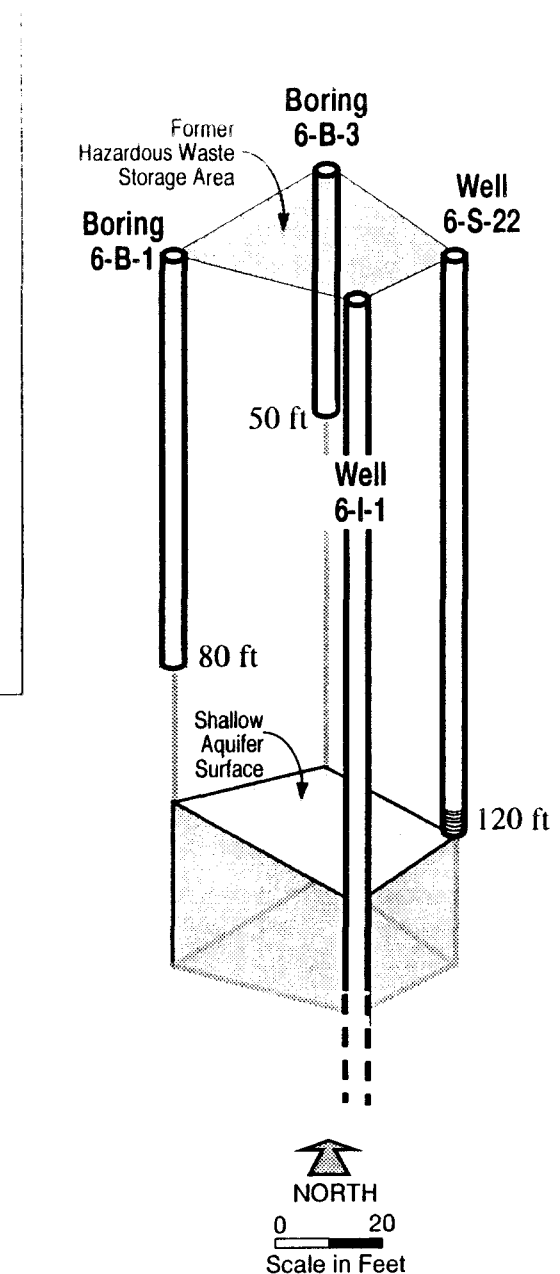
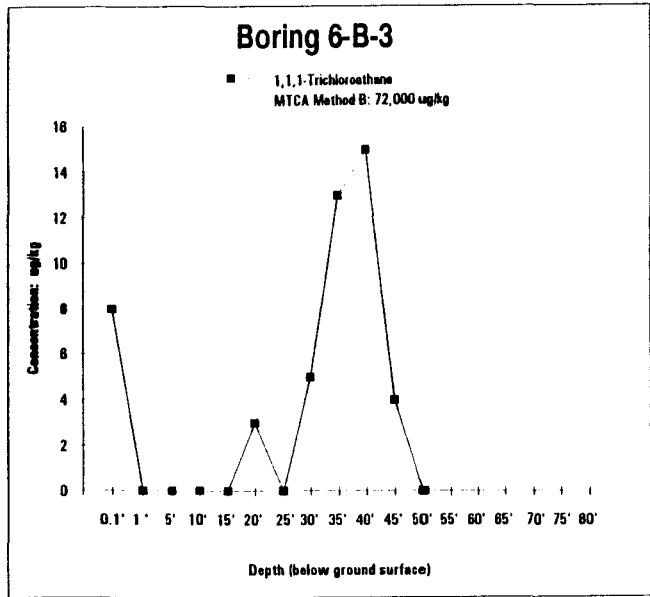
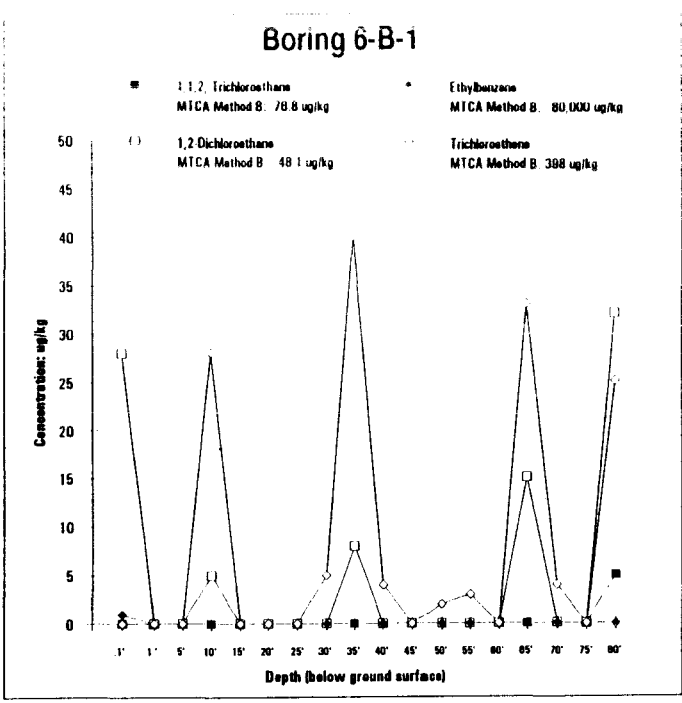

NOTE: MTCA Method B values are for soils based on groundwater protection.

CLEAN
COMPREHENSIVE LONG-TERM ENVIRONMENTAL ACTION NAVY

Figure 6
Concentrations of Volatile Organic Compounds in Soils From Former Hazardous Waste Storage Area

CTO 0005
OPERABLE UNIT 1
NAS WHIDBEY, WA
ROD

Table 6
Summary of Soil Sampling Results in All Area 6 Locations Except Former Hazardous Waste Storage Area

Analyte	Background Value	Range of Concentration	Frequency of Detection	Range of Detection Limits
V-CLP ($\mu\text{g}/\text{kg}$)				
1,1,1-Trichloroethane	NA	3 - 280	13/189	6 - 15U
1,1-Dichloroethane	NA	6 - 10	3/183	6 - 12U
1,1-Dichloroethene	NA	39	2/187	5 - 11U
1,2-Dichloroethane	NA	5 - 12	8/182	5 - 52U
1,2-Dichloroethene	NA	8	10/182	5 - 11U
Methyl chloride	NA	3 - 220	15/164	5 - 23U
Metals (mg/kg)				
Aluminum	13,718	2,500 - 13,800	176/177	17.00U
Antimony	10.4	7.7 - 18.9	12/142	6.4 - 16.8U
Arsenic	4	0.48 - 11.0	148/155	0.4 - 3.8U
Barium	120	13 - 564	196/197	NA
Calcium	4,508	1,500 - 8,620	200/209	NA
Chromium	35	10.4 - 80.2	161/178	12.6 - 21.2U
Copper	18	3.4 - 170.5	184/188	7.8 - 13.0U
Iron	17,226	17 - 21,900	202/202	NA
Lead	17.8	1.2 - 86.3	114/122	7.2 - 8.1U
Magnesium	8,492	710 - 13,500	202/202	NA
Manganese	847	90 - 2,940	200/201	1,970U
Nickel	62.3	15 - 134	178/178	NA
Potassium	745	216 - 1,060	167/200	304 - 1,318U
Sodium	242	67.5 - 464	142/142	15 - 689U

Table 6 (Continued)
Summary of Soil Sampling Results in All Area 6 Locations Except Former Hazardous Waste Storage Area

Analyte	Background Value	Range of Concentration	Frequency of Detection	Range of Detection Limits
Vanadium	37.7	6.7 - 206	200/200	NA
Zinc	49	17.5 - 220.5	153/159	19.5 - 23.4U

Notes:

V-CLP - volatiles analysis—Contract Laboratory Program

 $\mu\text{g}/\text{kg}$ - micrograms per kilogram

NA - not applicable

U - not detected

 mg/kg - milligrams per kilogram

baseline indicating what risks could exist if no action were taken at the site. This section of the ROD reports the results of the baseline risk assessment conducted for OU 1.

7.1 Human Health Risk Assessment

A baseline risk assessment was developed to evaluate potential human health risks associated with exposure to chemicals at Areas 5 and 6 of OU 1. This risk assessment followed four basic steps to accomplish this goal:

- Identification of chemicals and media of potential concern for the site
- Assessment of possible human exposures to site chemicals under both current and future land use scenarios
- Evaluation of the toxicity of site chemicals
- Evaluation of the characterization of potential health risks for populations

The approaches used and assumptions made in accomplishing these objectives are presented in detail in the final RI/FS and are summarized in the following sections.

7.1.1 Screening Evaluation to Identify Chemicals and Media of Potential Concern

A screening assessment for each medium (e.g., soil, surface water) at OU 1 was performed to determine if chemicals were present at concentrations above health-protective levels. The preliminary results of this screening assessment were compared with conservative risk levels designated as acceptable by EPA. (For groundwater, the risks designated acceptable by EPA are 10^{-6} risk for carcinogenic effects and a hazard index [HI] of 1.0 or less for noncarcinogenic effects. For soils, the risk levels designated as acceptable by EPA are 10^{-7} risk for carcinogenic effects and an HI of 0.1 or less for noncarcinogenic effects.) If the medium being evaluated was at or below an acceptable risk-based level, that medium was screened, or eliminated, from a more rigorous and site-specific quantitative evaluation. There were also additional considerations that influenced the decision to screen media from the risk assessment, such as the frequency of detection and the natural background concentration of inorganic chemicals.

A screening-level risk evaluation was conducted for each of the different media present at Areas 5 and 6, including surface water, soil, sediments, groundwater, and air. A chemical-specific risk-based screening was not performed.

Surface Water. A screening-level risk evaluation was performed for a hypothetical resident at Areas 5 and 6. Both the carcinogenic and noncarcinogenic risks associated with potential ingestion of surface water were below EPA's acceptable risk range. The

HI's for both areas were less than 1. The screening-level cancer risks for a resident child were 7×10^{-8} and 6×10^{-7} for Areas 5 and 6, respectively. The screening-level risks for surface water at Area 6 were entirely attributable to arsenic (greater than 99 percent). Although it is likely that much of the arsenic risk is a result of naturally occurring levels, no background surface water samples were taken because a representative background station for surface water was not found. Therefore, a comparison of site and background concentrations cannot be made. Because this screening-level analysis indicated that exposure to the maximum detected concentrations of chemicals in surface water, including arsenic, would not exceed acceptable risk levels, this medium was determined not to pose a risk to human health and was eliminated from further evaluation.

Soil. Screening-level risks associated with exposure to soil by a resident were evaluated by the ingestion pathway. In evaluating this pathway it was assumed that a resident will ingest soil from the site on a daily basis for 30 years. At Area 5, both cancer and noncancer risks were below EPA's acceptable risk levels. The screening-level cancer risk for an Area 5 resident ingesting soil was 3×10^{-9} and the noncancer HI was 0.05. Screening-level risks for Area 6 soils exceeded EPA's acceptable levels. The screening-level cancer risk for carcinogenic effects was 3×10^{-3} and the noncancer HI was 1.3.

Evaluation of the analytical data for soils in Area 6 indicated that a limited number of chemicals posed most of the potential risk. The screening-level soil risks at Area 6 were heavily influenced by the following:

- Single high detections of certain compounds that were often substantially greater than the rest of the sample population (e.g., beryllium and silver, which could not be duplicated with confirmatory sampling)
- High concentrations that are largely attributable to natural background levels (e.g., antimony and arsenic)
- Chemicals that were detected very infrequently (e.g., polynuclear aromatic hydrocarbons)

Because the screening risk estimates for Area 6 soils exceeded EPA's acceptable risk range, this medium was included in the baseline risk assessment for further evaluation.

Sediments. Screening-level risks for sediments were calculated using the same exposure assumptions as for soil. This overestimates probable sediment risks; actual exposures to sediments would occur less frequently than for soils, because the streams are intermittent.

Screening-level risks for sediments in both Areas 5 and 6 were initially found to exceed EPA's acceptable risk levels. The preliminary cancer and noncancer risk for sediments

at Area 5 were 3×10^{-4} and 1, respectively. Greater than 99 percent of the cancer risk and 50 percent of the noncancer risk for Area 5 were due to arsenic. Although the maximum detected concentration of arsenic in one of the three Area 5 sediment samples (11 milligrams per kilogram [mg/kg]) exceeded the calculated background level for arsenic in soil (6.0 mg/kg; background sediment samples were not taken), sediments at Area 5 were screened from further evaluation in the quantitative risk assessment for the following reasons:

- Arsenic was detected in only one out of three sediment samples.
- There is no on-site source of arsenic at Areas 5 and 6 (suggesting that the 11 mg/kg detection may be attributable, at least in part, to other sources).
- The single detection of arsenic is generally consistent with soil background levels of arsenic.
- The exposure assumptions used in the screening-level risk evaluation overestimate the probable exposure to sediments.

Screening-level cancer and noncancer risks from sediments at Area 6 were 3×10^{-4} and 1.3, respectively. Approximately 75 percent of the cancer risk from Area 6 sediments was due to arsenic. The maximum concentration of two pesticides, aldrin and heptachlor epoxide, also posed screening-level cancer risks greater than 10^{-6} . Aldrin and heptachlor epoxide were used as part of base-wide management procedures (i.e., pest control), and their presence in sediments is not thought to be a result of activities specifically related to Area 6. Arsenic and heptachlor epoxide were also responsible for most of the noncancer risks. The maximum detected concentration of heptachlor epoxide was 35 times greater than the only other heptachlor epoxide detection, indicating that the maximum detection is probably a statistical outlier and yields screening risks that greatly overestimate more realistic risks. Arsenic was not substantially elevated above background, and much of the screening-level risks for arsenic are not site-related. Based on these additional considerations of the analytical data for the site, sediments at Area 6 were not included in the quantitative risk assessment for OU 1.

Groundwater. Three groundwater aquifers (shallow, intermediate, and deep) were sampled at OU 1. The shallow aquifer has the greatest potential for contamination because of its physical proximity to the surface and source area soils. A screening-level risk assessment was conducted for all three aquifers at Area 6. Only the shallow aquifer was evaluated for Area 5.

The screening-level evaluation for groundwater combined two potential exposure pathways. These pathways included groundwater ingestion and inhalation of volatile chemicals released from groundwater during residential use. In evaluating this medium

it was assumed that a resident will ingest groundwater from the site on a daily basis for 30 years and that the same individual will be exposed to site chemicals from daily inhalation of volatile chemicals released from groundwater during bathing or cooking.

Screening-level risk for both carcinogens and noncarcinogens in groundwater at Areas 5 and 6 substantially exceeded EPA's acceptable risk levels. Chemicals of concern identified for the Area 6 shallow groundwater are summarized in Table 7. The screening risk estimates for the shallow aquifer at Area 6 were due primarily to volatile organic compounds, whereas the risks for the intermediate and deep aquifers were dominated by background levels of arsenic. Arsenic and manganese are the primary risk drivers in the shallow groundwater at Area 5, although volatile organic compounds also contributed to risk.

Table 7
Chemicals of Concern for Area 6 Shallow Groundwater

	EPA Safe Drinking Water Act 40 CFR 141 MCLs ($\mu\text{g/L}$)	MTCA Method B Formula Values WAC 173-340 ($\mu\text{g/L}$)	Maximum Concentrations ($\mu\text{g/L}$)
1,1-Dichloroethane	ND	800	26
1,1-Dichloroethene	7	0.07	1,900
1,2-Dichloroethene	70	80	630
1,1,1-Trichloroethane	200	720	32,000
Trichloroethene	5	4	1,800
Vinyl chloride	2	0.02	53.5

Notes:

MCL - maximum contaminant level

$\mu\text{g/L}$ - micrograms per liter

ND - not determined at this time

Because the screening-level risk estimates exceeded EPA's acceptable risk level, groundwater was not screened from the risk assessment. A quantitative evaluation of potential groundwater risks was performed in the baseline risk assessment, and is summarized at the end of this section.

Air. A screening risk evaluation that considered the potential for exposure to airborne contaminants at Area 6 was also performed. The on-site resident scenario was evaluated

using measured concentrations of particulates and vapors at the site. Actual concentrations of chemicals in air were obtained from ambient air monitoring conducted at Area 6, as well as from emission flux measurements for chemicals volatilizing from the soil. The exposure of the nearest current off-site resident was evaluated using computer modeling techniques to estimate emission and dispersion of volatile chemicals. Maximum values of both measured and modeled chemical concentrations were used in the screening risk evaluation.

The initial risk screen for carcinogenic effects for the hypothetical on-site resident based on measured data is within EPA's acceptable risk range, with a maximum calculated risk of 2×10^{-5} . This risk is attributable primarily to assumptions made regarding the toxicity of chromium and nickel. The default assumption made in the screening risk assessment was that the chromium and nickel detected in the ambient air were the most toxic and carcinogenic forms of both metals. The carcinogenic forms of chromium and nickel are typically associated with industrial activities, such as plating and smelting operations, and would not make up a significant percentage of the total chromium and nickel present in the soil or air at nonindustrial sites such as OU 1. If it were assumed that the chromium and nickel detected in the ambient air were the noncarcinogenic forms, the resulting screening risk estimates would not exceed EPA's acceptable level. Consideration of the risks contributed by natural background levels of chromium and nickel would reduce the apparent site-related risks. Levels of volatile chemicals at Area 6 did not pose an unacceptable risk.

Screening air modeling was also done to evaluate the potential risks to the nearest current off-site resident. Both cancer and noncancer risk estimates were below EPA's acceptable risk level. Because the screening risks to on- and off-site residents from measured and modeled volatile organic compounds were not significant, and because particulate risks were acceptable after adjusting the toxicity assumptions for chromium and nickel, the ambient air exposure pathway did not appear to pose a significant health risk and was not included in the quantitative baseline risk assessment.

Summary of Media and Chemicals of Potential Concern. Groundwater and soil were selected for more detailed evaluation in the quantitative risk assessment. Surface water, sediments, and air were eliminated from the risk assessment based on a screening-level risk analysis. Volatile organic compounds and inorganics in groundwater were identified as the primary chemicals of concern at Areas 5 and 6. However, all chemicals that were detected in soil and groundwater were evaluated in the quantitative risk assessment.

7.1.2 Exposure Assessment

The exposure assessment is a critical part of a baseline risk assessment, because it defines the populations and potential exposure pathways that will be evaluated. The exposure assessment has four principal objectives:

- Identification of populations that may be exposed to chemicals at the site
- Identification of potential exposure pathways
- Estimation of the representative concentrations of chemicals in each medium (the exposure point concentration)
- Selection of exposure assumptions and calculation of chronic daily intake of site chemicals

Selection of Potentially Exposed Populations. Three potentially exposed populations were selected for evaluation at Areas 5 and 6. The exposure scenarios evaluated in this baseline risk assessment include a future on-site residential scenario, a future on-site occupational scenario, and a current/future on-site trespasser scenario (future trespasser exposures were considered to be equivalent to current). Off-site resident risks have also been evaluated.

For the screening analysis, the future residential scenario evaluated potential exposures and risks from soil, groundwater, surface water, sediment, and air. The future occupational scenario evaluated exposures to both soil and groundwater. (Exposures of workers to other media were assumed to be insignificant, because the screening-level evaluation for the more conservative residential scenario did not result in unacceptable risks.) Risks (screening level only) for the trespasser scenario were evaluated for soil, sediment, and surface water, and were found to be insignificant.

Selection of Possible Exposure Pathways. Possible exposure pathways have been identified for each potentially exposed population at OU 1. The potential exposure pathways considered at OU 1 are presented in Table 8.

Calculation of Exposure Point Concentrations. An exposure point concentration (EPC) represents the medium-specific concentration of a chemical with which an exposed human may come into contact. For CERCLA risk assessments the EPC is intended to be an upper-bound representation of the average site concentration, such as the 95 percent upper confidence limit (UCL) on the mean (95 percent UCL). If, however, the 95 percent UCL exceeds the maximum detected concentration (on account of, for example, extreme variability in analytical results), then the maximum concentration is used instead.

As noted earlier, the maximum detected concentration of chemicals in all media was used in the screening-level risk evaluation. For soils, the maximum single sample concentration at any depth between the surface and 15 feet was used as an EPC. A quantitative evaluation of potential groundwater risks was performed for each monitoring well in Areas 5 and 6. For each of these wells, the data from as many as six rounds of

Table 8
Potential Exposure Pathways for Populations at Operable Unit 1

Potentially Exposed Population	Medium of Concern	Exposure Pathway
Future on-site resident	Groundwater	Ingestion
	Groundwater	Inhalation
	Soil	Ingestion
	Sediment	Ingestion ^a
	Surface water	Ingestion ^a
	Particulates in air	Inhalation ^a
	Volatile chemicals in air	Inhalation ^a
Current off-site resident	Volatile chemicals in air	Inhalation ^a
Future on-site worker	Groundwater	Ingestion
	Groundwater	Inhalation
	Soil	Ingestion ^a
On-site trespasser	Soil	Ingestion ^a
	Sediment	Ingestion ^a
	Surface water	Ingestion ^a

^aThese pathways were evaluated only in the screening-level risk assessment. The screening-level assessment provided preliminary risk estimates based on the maximum detected concentration of all chemicals in each respective medium.

sampling were evaluated. The 95 percent UCL was calculated for each chemical in each well from all available data (beginning with the Initial Investigation in 1989). Because the quantitative risk assessment did not evaluate risks from chemicals in soils, sediments, surface water, and air beyond a screening level, a 95 percent UCL was not calculated for chemicals in these media.

Selection of Exposure Assumptions and Calculation of Chronic Daily Intake of Site Chemicals. Estimates of potential human intake (called chronic daily intake, or CDI) of site chemicals must be calculated for each exposure pathway. Calculation of the CDI requires development of pathway-specific exposure assumptions for each medium of concern. Exposure estimates for chemicals at OU 1 were calculated using a combination of federal and EPA Region 10 default and site-specific exposure assumptions. In several cases (e.g., exposure frequency of a trespasser or intake rate of surface water), the default exposure parameter was not considered appropriate for this site. In these cases, exposure parameters were developed that are more site-specific. For the groundwater pathway, default exposure parameters were used.

7.1.3 Toxicity Assessment

The purpose of the toxicity assessment is to identify chemical- and route-specific toxicity criteria values for each chemical of potential concern. These toxicity values are used in conjunction with the exposure estimates to calculate the potential human health risks. To evaluate the potential health risks associated with exposure to a chemical, both carcinogenic and noncarcinogenic health effects must be considered. The toxicity factors used in this risk assessment have been developed by the EPA and are current through June 1992 with one exception. The primary source for toxicity values is EPA's Integrated Risk Information System (IRIS) and the secondary source is the Health Effects Assessment Summary Tables (HEAST). The reference dose (RfD) for manganese in water was updated in IRIS in May 1993, after the risk assessment was completed in April 1993. The RfD for manganese in Area 6 groundwater was updated in the final RI/FS (June 1993) to reflect the latest EPA recommendations. Toxicity values for the chemicals that are responsible for the majority of risks in the shallow aquifer at Areas 5 and 6 are presented in Table 9.

RfDs were developed by EPA to represent daily intakes of chemicals to which an individual, including sensitive subpopulations, can be exposed without any expectation of noncarcinogenic adverse health effects (e.g., organ damage, biochemical alterations, birth defects). RfDs are expressed as milligrams chemical/kilogram body weight per day of exposure (mg/kg-day). Noncarcinogenic chemicals are thought to exhibit a "threshold," wherein exposures less than a specific threshold dose will not result in adverse health effects. RfDs have not been developed for all noncarcinogens, primarily because of a lack of toxicity data. Noncancer risks were not calculated for chemicals lacking RfDs.

Cancer slope factors (CSFs) are used to evaluate the carcinogenicity of chemicals. A CSF is a numerical estimate of the potency of a chemical, which, when multiplied by the average lifetime dose, gives the probability of an individual developing cancer over his or her lifetime. The CSFs are expressed as the inverse of milligrams of contaminant per kilogram of body weight per day (mg/kg-day)⁻¹. It is assumed by EPA in developing CSFs that the risk of cancer is linearly related to dose. Carcinogens are assumed to be without a toxicity threshold, because theoretically there is no level of exposure for these chemicals that does not pose a small, but finite, probability of generating a carcinogenic response. CSFs correspond to the upper-bound limit of cancer potency of a chemical, and, as a result, the calculated carcinogenic risk is likely to represent an upper limit to the risk. The actual risk is unknown but is likely to be lower than the predicted risk, and may be as low as zero.

Table 9
Toxicity Values for Chemicals Responsible for the Majority of Risks in
the Shallow Aquifer at Areas 5 and 6

Chemical	Chronic Reference Dose (mg/kg-day)		Slope Factor (mg/kg-day) ⁻¹	
	Inhalation	Ingestion	Inhalation	Ingestion
Area 5				
Arsenic ^a	NA	3×10^{-4}	15	1.75
Manganese ^b	1.1×10^{-4}	5×10^{-3}	NA	NA
Area 6				
Carbon tetrachloride	NA	7×10^{-4}	5.3×10^{-2}	1.3×10^{-1}
1,1-Dichloroethene	NA	9×10^{-3}	1.8×10^{-1}	6.1×10^{-1} ^c
1,2-Dichloroethene	NA	1×10^{-2}	NA	NA
1,1,1-Trichloroethane	NA	9×10^{-2}	NA	NA
Trichloroethene	NA	1×10^{-2}	1.1×10^{-2}	5.95×10^{-3} ^c
Vinyl chloride	NA	1.3×10^{-3}	3×10^{-1}	1.9

^aThe noncancer risk for arsenic was not found to exceed a hazard quotient of 1 at Area 5.

^bThe reference dose for manganese in water was updated to reflect the 1993 revision in IRIS. Only groundwater risks at Area 6 were updated.

^cToxicity values for both noncarcinogenic and carcinogenic effects are generally calculated from critical effect levels based on an administered, rather than absorbed, dose. These administered inhalation reference doses were adjusted by percent absorption values to yield an absorbed reference dose.

Notes:

mg/kg-day - milligrams per kilogram per day

NA - no toxicity value available

7.1.4 Risk Characterization

For carcinogens, risks are estimated as the incremental probability of an individual developing cancer over a lifetime as a result of the exposure to the carcinogen. Excess lifetime cancer risk is calculated from the following equation:

$$\text{Risk} = \text{CDI} \times \text{SF}$$

Where:

Risk = A unitless probability (e.g., 2×10^{-5}) of an individual developing cancer

CDI = Chronic daily intake averaged over 70 years, expressed as mg/kg-day

SF = Slope-factor, expressed as (mg/kg-day)⁻¹

These risks are probabilities that are generally expressed in scientific notation (e.g., 1×10^{-6}). An excess lifetime cancer risk of 1×10^{-6} indicates that, as a reasonable maximum estimate, an individual has a 1 in 1,000,000 chance of developing cancer as a result of site-related exposure to a carcinogen over a 70-year lifetime under the specific exposure conditions at a site. The acceptable risk range identified by EPA for carcinogens is 10^{-4} to 10^{-6} (risks from 1 in 10,000 to 1 in 1,000,000).

The potential for noncarcinogenic effects is evaluated by comparing an exposure level over a specified time period (e.g., lifetime) with an RfD derived for a similar exposure period. The ratio of exposure to toxicity is called a hazard quotient (HQ). By adding the HQs for all contaminants of concern that affect the same target organ (e.g., liver) within a medium or across all media to which a given population may reasonably be exposed, the HI can be generated.

The HQ is calculated as follows:

$$\text{Noncancer HQ} = \text{CDI/RfD}$$

Where:

CDI = Chronic daily intake (mg/kg-day)

RfD = Reference dose (mg/kg-day)

CDI and RfD are expressed in the same units and represent the same exposure period (i.e., chronic, subchronic, or short-term).

If the HI is less than 1.0, it indicates that noncarcinogenic health effects are unlikely. If the total HI is greater than 1.0, it indicates that adverse health effects are possible and suggests that additional evaluation may be necessary.

Potential human health risks associated with exposure to groundwater at OU 1 were evaluated on a well-by-well, rather than a site-wide, basis. That is, the 95 percent UCL for each chemical detected in each well was used to calculate risk. The risk estimates assume that both residents and workers will ingest site groundwater and inhale volatile chemicals released from the water during cooking or bathing.

Area 5. Risks for potential residential and occupational use of groundwater in the shallow aquifer were evaluated in the quantitative risk assessment. The risks from future occupational use of Area 5 groundwater were approximately one-third of those calculated for the future residential scenario. A summary of the carcinogenic and

noncarcinogenic risks resulting from potential future groundwater exposure is shown in Table 10.

Table 10
Potential Human Health Risks Associated With Future Residential or Occupational Use of Groundwater From the Shallow Aquifer at Area 5

Monitoring Well Number	Noncancer Hazard Index for Future Workers	Cancer Risks for Future Workers	Noncancer Hazard Index for Future Residents	Cancer Risks for Future Residents
5-S-01	0.8	1×10^{-4}	2.1	3×10^{-4}
N5-14	0.3	2×10^{-5}	1.0	6×10^{-5}
N5-15	0.9	5×10^{-5}	2.4	2×10^{-4}
N5-16	1.2	5×10^{-5}	3.3	2×10^{-4}

Note: Between 50 and 100 percent of the cancer risks resulting from exposure to groundwater in the shallow aquifer at Area 5 were due to arsenic. Both the cancer and noncancer risks for Area 5 groundwater are largely due to background levels of arsenic. No volatile organic compounds posed risks above EPA's acceptable range.

Potential human health risks resulting from exposure to other media at Area 5 were also evaluated. Screening-level risks for future residents and trespassers were calculated for soil, sediments, and surface water. Screening risks for workers exposed to soil were also calculated. A site-specific risk assessment was not developed for these media, because the conservative screening-level risks were acceptable.

Arsenic in groundwater was the only chemical that exceeded EPA's acceptable cancer risk range. The arsenic concentration in the shallow aquifer at Area 5 ranged from 3.1 to 17 $\mu\text{g}/\text{L}$. The site-specific background concentration of arsenic in the shallow aquifer is 8.4 $\mu\text{g}/\text{L}$. Therefore, between 50 percent and 100 percent of the shallow aquifer risks (both cancer and noncancer) are attributable to background levels of arsenic. Because there is no known source of arsenic at Area 5, it is likely that all the arsenic risks for the shallow aquifer are due to natural background levels. In addition, manganese exceeded an HQ of 1.0 in two wells at Area 5 (i.e., N5-15 has an HQ of 1.4 and N6-16 has an HQ of 1.2).

Area 6. Risks for potential residential and occupational use of groundwater in the shallow, intermediate, and deep aquifers were evaluated in the quantitative risk assessment. The potential human health risks for both workers and residents from Area 6 groundwater exceeded EPA's acceptable risk range for most wells in the three

aquifers. Arsenic (primarily present at background levels) was the main risk driver for the intermediate and deep aquifers. In general, volatile organic compounds, including carbon tetrachloride, trichloroethene, 1,1-dichloroethene, 1,2-dichloroethene, 1,1,1-trichloroethane, and vinyl chloride, were responsible for the majority of the risks in the shallow aquifer. A summary of the cancer and noncancer risks for future residential use of the groundwater from each monitoring well in Area 6 is shown in Table 11.

Because this risk assessment evaluated risks on a well-by-well basis, a sitewide groundwater risk was not calculated. Therefore, although the assessment determined the chemicals that present the highest risk at each well, it does not identify the chemicals that pose the highest risk when combining data from all the wells. Evaluation of the risks for each well in the different aquifers indicated that a limited list of chemicals comprised most of the carcinogenic and noncarcinogenic risks. These chemicals are presented in Table 12.

Potential human health risks resulting from exposure to other media at Area 6 were also evaluated. Conservative screening-level risks for future residents and trespassers at the site were calculated for soil, sediments, surface water, and ambient air. Screening risks for workers exposed to soil were also evaluated. Although several of these media had screening risk levels that exceeded EPA's acceptable risk levels, site-specific considerations of the chemicals and media indicated that significant risks from these media would not occur.

Potential risks from exposure to soil were also evaluated. The results of the screening risk assessment, when combined with site-specific considerations, indicated that exposure to soils at Area 6 would not pose an unacceptable risk. The site-specific factors influencing the soil risk at Area 6 included single high detects of certain compounds (e.g., beryllium and silver; subsequent resampling could not confirm these high levels), contributions to risk from naturally occurring background levels of inorganics (e.g., antimony and arsenic), or a low frequency of detection (e.g., polynuclear aromatic hydrocarbons). Volatile organic compounds that are chemicals of concern in the groundwater do not pose an unacceptable risk in soils, as shown in Table 13.

7.1.5 Uncertainty Analysis

The accuracy of a risk assessment depends to a large extent on the quality and representativeness of the data and assumptions that are used. Particularly critical are assumptions about the distribution of chemicals in different media, the types and ranges of possible exposures, the toxicity of the chemicals found at the site, and the approaches used to characterize risk. In a baseline risk assessment, much of the data and many of the assumptions are conservative, so that the resulting risk estimates are intended to overestimate, rather than underestimate, the most likely risks.

Table 11
Well-by-Well Evaluation of the Potential Human Health Risks Associated With
Future Residential Use of Groundwater at Area 6

Aquifer Well Number	Noncancer Hazard Index	Cancer Risk
Shallow		
N6-37	31 ^a	8 x 10 ⁻³
N6-38	194 ^a	3 x 10 ⁻²
6-S-2	0.6	NA
6-S-3	0.1	2 x 10 ⁻⁴
6-S-4	0.2	3 x 10 ⁻⁴
6-S-6	8.2	1 x 10 ⁻²
6-S-7	0.01	6 x 10 ⁻⁷
6-S-9	0.5	NA
6-S-10	1.3	6 x 10 ⁻³
6-S-12	1.6	6 x 10 ⁻⁴
6-S-13	0.8	2 x 10 ⁻⁴
6-S-14	1.0	2 x 10 ⁻⁴
6-S-15	0.003	9 x 10 ⁻⁶
6-S-16	0.2	9 x 10 ⁻⁴
6-S-17	0.1	2 x 10 ⁻⁴
6-S-19	0.98	4 x 10 ⁻⁴
6-S-21	10.1	NA
6-S-23	0.1	NA
6-S-24	0.4	2 x 10 ⁻⁴
6-S-25	3.8	4 x 10 ⁻³
Intermediate		
6-I-1	0.87	5 x 10 ^{-4b}
6-I-2	2 ^b	1 x 10 ^{-3b}
6-I-3	43 ^b	2 x 10 ^{-3b}
6-I-4	2.4 ^b	1 x 10 ^{-3b}
6-I-6	0.07	3 x 10 ⁻⁴
6-I-8	1.5	7 x 10 ^{-4b}

Table 11 (Continued)
Well-by-Well Evaluation of the Potential Human Health Risks Associated With
Future Residential Use of Groundwater at Area 6

Aquifer Well Number	Noncancer Hazard Index	Cancer Risk
Deep		
6-D-1	2.5 ^b	1 x 10 ^{-3b}
6-D-2	7.3 ^b	4 x 10 ^{-3b}
6-D-5	4.2 ^b	2 x 10 ^{-3b}

^aThese risks are associated primarily with carbon tetrachloride. Although carbon tetrachloride was detected in the interim sampling, it was not detected in the RI Phase 2 or Phase 3 sampling. As a result of this sporadic detection, the risks associated with exposure to carbon tetrachloride in groundwater are highly uncertain.

^bThese risks are attributable to background concentrations of arsenic.

Notes:

NA - not applicable

Shaded value - cancer risk greater than 1 x 10⁻⁴ or noncancer hazard index greater than 1.0

Table 12
Chemicals Contributing to Potential Health Risks for the
Future Residential Users of Groundwater at Area 6

Aquifer	Chemicals Posing Significant Noncancer Risks ^a	Chemicals Posing Significant Cancer Risks ^b
Deep	Antimony Arsenic ^c	Arsenic ^c
Intermediate	Arsenic ^d	Arsenic ^d Vinyl chloride
Shallow	Arsenic ^e Carbon tetrachloride ^f 1,1-Dichloroethene 1,2-Dichloroethene 1,1,1-Trichloroethane Trichloroethene	Arsenic ^e Carbon tetrachloride ^f 1,1-Dichloroethene Trichloroethene Vinyl chloride

^aA significant noncancer risk corresponds to a hazard quotient of 1.0 or greater for each chemical listed. The concentrations of antimony and arsenic were similar to background levels. Risks were evaluated assuming exposure by both ingestion of groundwater and inhalation of volatile chemicals released from the water during cooking or bathing.

^bA significant cancer risk was assumed to be 10^{-4} , the upper end of EPA's acceptable risk range. The concentrations of arsenic in the different aquifers were similar to background levels. Risks were evaluated assuming exposure by both ingestion of groundwater and inhalation of volatile chemicals released from the water during cooking or bathing.

^cBetween 75 and 100 percent of the risk is attributable to background.

^dAll risks (except for well 6-I-6) are attributable to background concentrations of arsenic.

^eBackground concentrations of arsenic contribute or large percentage of the risk.

^fThese risks are highly suspect due to the low frequency of detection.

Table 13
Potential Human Health Risks Associated With
Future Resident Exposure to Soil at Area 6

Chemical	Noncancer Hazard Index	Cancer Risk
1,1-Dichloroethane	NA	NA
1,1-Dichloroethene	NA	NA
1,2-Dichloroethene	2×10^{-6}	NA
1,1,1-Trichloroethane	8×10^{-7}	NA
Trichloroethene	1×10^{-5}	5×10^{-10}
Vinyl chloride	NA	NA

Notes:

Risks are presented only for chemicals found to be of concern in the shallow aquifer at Area 6.

NA - chemical not detected in soil or no toxicity data available

In addition to the uncertainties due to the risk assessment methodology, there are several site-specific uncertainties that affect risk calculations. The limited detection frequency for certain chemicals (e.g., carbon tetrachloride in groundwater), the contribution from natural background chemicals (e.g., arsenic, manganese), the cancer slope factor for arsenic (which EPA notes is somewhat conservative and likely to overestimate arsenic risks), and the representativeness of the exposure scenarios (e.g., the likelihood that someone will build a house on a landfill) all affect the results and interpretations of the risk calculations. Because of the assumptions made in this risk assessment, the estimates of risk are conservative and health-protective.

7.2 Ecological Risk Assessment

To assess the environmental effects of the contaminants present at the site, an evaluation of potentially affected terrestrial species was conducted. A site-specific wildlife survey was not conducted as part of the remedial investigation. However, it is known that the Townsend's vole, coyotes and northern harriers inhabit the site. The bald eagle, a federally threatened species in the state of Washington, has also been observed in the vicinity of the site.

Area 5 and Area 6 were evaluated separately. Area 6 is made up of two distinct habitat types (meadow/grassland and forest transition zone) that were evaluated separately by ecological modeling.

The primary concern for this site is terrestrial wildlife exposure to metals through ingestion of soil and food. However, inhalation of volatile vapors by small burrowing

rodents was also evaluated. These exposure routes were modeled to estimate reasonable maximum exposures to three receptors with three different foraging patterns: herbivorous small mammal (Townsend's vole), carnivorous mammal (coyote), and carnivorous bird (northern harrier). Exposure modeling indicated potential risks to small herbivorous mammals from chromium, nickel, and vanadium at Area 5, and chromium, nickel, vanadium, and lead at Area 6 (Table 14). No risks were estimated for either of the carnivorous receptors in Area 5; however, there is a potential risk to mammalian carnivores from mercury and lead at Area 6.

At Area 5, a 19-acre freshwater wetland is located approximately 600 feet west of the excavation area. At Area 6, a small intermittent stream flows northwest discharging into an off-site 18-acre wetland. The stream is classified as a jurisdictional wetland under Section 404 of the Clean Water Act. The ecological risk for the wetlands was evaluated using two methods:

- Comparison of reasonable maximum chemical concentrations in the sediments to Ecology sediment quality guidelines that were developed based on long-term effects to benthic organisms
- Comparison of maximum likely surface water chemical concentrations to EPA's AWQC

Sediment quality guidelines are exceeded for six metals and two pesticides in Area 5 (arsenic, chromium, copper, iron, manganese, nickel, endrin, and 4,4'-DDT), and four metals and two pesticides in Area 6 (arsenic, chromium, copper, nickel, heptachlor epoxide, and aldrin). These exceedances are identified as HQs greater than 1.0 in Table 15. AWQC were exceeded for five metals in Area 5 (cadmium, copper, lead, silver, and zinc) and four metals in Area 6 (arsenic, chromium, copper, and nickel) (Table 16). These comparisons indicate organisms inhabiting the aquatic systems on this site could potentially be affected by metals in both the sediments and the water and pesticides in the sediment.

8.0 REMEDIAL ACTION OBJECTIVES

8.1 Need for Remedial Action at Area 6

Ecological risk was identified for Area 6 soils and for sediments and surface water from the intermittent stream at Area 6. However, no source area was located and remedial action could cause more environmental harm than the low levels of existing chemicals are likely to cause.

Table 14
Ecological Hazard Quotients Determined for Terrestrial Receptors

Chemical Name	Hazard Quotients		
	Vole	Coyote	Northern Harrier
Area 5			
Arsenic	3.1×10^{-2}	4.8×10^{-4}	7.1×10^{-3}
Beryllium	--	--	--
Chromium	1.9	2.5×10^{-1}	3.3×10^{-1}
Nickel	1.4×10^1	5.1×10^{-3}	--
Vanadium	2.5	7.1×10^{-3}	1.4×10^{-2}
Heptachlor epoxide	3.4×10^{-4}	1.1×10^{-5}	--
Area 6A (Grassland/Meadow)			
Antimony	--	--	--
Arsenic	3.0×10^{-2}	4.7×10^{-4}	6.9×10^{-3}
Beryllium	--	--	--
Chromium	1.7	2.3×10^{-1}	3.0×10^{-1}
Nickel	1.1×10^1	4.1×10^{-2}	--
Aldrin	2.1×10^{-1}	2.5×10^{-1}	--
Heptachlor epoxide	4.8×10^{-2}	1.6×10^{-3}	--
Area 6B (Forest Transition Zone)			
Antimony	--	--	--
Chromium	1.20	1.6×10^{-1}	--
Inorganic Mercury	5.6×10^{-1}	1.3	--
Lead	7.0×10^1	1.2×10^1	--
Nickel	1.3×10^1	5.0×10^{-2}	--
Vanadium	2.4	6.8×10^{-3}	--
Ethylbenzene	4.6×10^{-6}	4.2×10^{-7}	9.4×10^{-5}
1,1,1-Trichloroethane	2.0×10^{-4}	1.7×10^{-4}	3.7×10^{-3}

Notes:

-- means no toxicity reference value available.

Shaded value means hazard quotient exceeds 1.0.

Table 15
Ecological Hazard Quotients for Chemicals in Sediment at Areas 5 and 6

Chemical Name	Area 5			Area 6				
	5A1	5A2	5A3	6A1	6A2	6A3	6A4	6A5
Aluminum	--	--	--	--	--	--	--	--
Arsenic	1.88	0.32	0.65	1.55	0.92	0.62	1.27	0.67
Barium	NC	NC	NC	--	--	--	--	--
Chromium	2.38	0.75	1.15	1.33	0.92	1.23	1.54	1.3
Cobalt	NC	NC	NC	0.18	0.08	--	0.14	0.1
Copper	3.06	0.4	1.27	2.73	1.09	1.44	1.55	1.11
Iron	1.44	0.22	0.39	1.0	0.54	0.4	0.8	0.71
Lead	0.15	0.15	0.27	0.63	0.27	0.17	0.25	0.21
Manganese	1.64	0.08	0.33	0.58	0.55	0.26	0.67	0.38
Mercury	NC	NC	NC	--	--	--	0.54	--
Nickel	9.25	1.14	2.73	4.23	2.38	5.32	5.57	4.89
Vanadium	--	--	--	--	--	--	--	--
Zinc	0.6	0.21	0.41	0.53	0.22	0.25	0.34	0.23
Aldrin	NC	NC	NC	--	38.5	--	--	--
alpha-Chlordane	--	--	0.02	NC	NC	NC	NC	NC
4,4-DDE	0.12	--	--	NC	NC	NC	NC	NC
4,4-DDT	0.07	1.06	1.57	NC	NC	NC	NC	NC
Dieldrin	0.38	0.18	--	--	0.85	--	--	--
Endosulfan I	--	--	0.11	NC	NC	NC	NC	NC
Endosulfan II	NC	NC	NC	--	0.95	--	--	--
Endrin	1.57	0.4	--	--	0.63	--	--	--
gamma-Chlordane	0.06	0.06	--	NC	NC	NC	NC	NC

Table 15 (Continued)
Ecological Hazard Quotients for Chemicals in Sediment at Areas 5 and 6

Chemical Name	Area 5			Area 6				
	5A1	5A2	5A3	6A1	6A2	6A3	6A4	6A5
Heptachlor epoxide	0.6	--	--	--	0.95	--	--	--
MCPA	--	--	--	--	--	--	--	--

Notes:

-- means no toxicity reference value available.

Shaded value means hazard quotient exceeds 1.0.

NC means not a chemical of concern for this area.

DDE - dichlorodiphenyl dichloroethene

DDT - dichlorodiphenyl trichloroethane

MCPA - 2-methyl-4-chlorophenoxyacetic acid

Table 16
Ecological Hazard Quotients for Chemicals in Surface Water at Areas 5 and 6

Chemical Name	Area 5			Area 6					
	5W1	5W3	5W3	6W1	6W2	6W3	6W4	6W5	6W6
Aluminum	1.8	16	9.9	5.46	386.21	98.85	36.55	181.61	10.68
Antimony	NC	NC	NC	0.02	0.02	0.02	0.02	0.02	0.02
Arsenic	NC	NC	NC	0.02	0.08	0.03	0.02	0.05	0.02
Barium	--	--	--	--	--	--	--	--	--
Cadmium	1.8	3.8	4.32	3.55	1.03	1.32	1.54	1.43	2.87
Chromium	0.02	0.07	0.07	0.36	7.55	1.71	0.84	3.16	0.36
Cobalt	NC	NC	NC	--	--	--	--	--	--
Copper	0.54	2.0	2.36	1.18	2.21	0.78	0.57	1.33	0.81
Iron	0.31	0.96	0.4	0.00	0.00	9.52	0.00	0.00	6.83
Lead	0.28	2.7	1.2	9.78	4.38	1.37	0.4	1.52	1.23
Manganese	--	--	--	--	--	--	--	--	--
Nickel	0.05	0.2	0.3	0.16	0.79	0.33	0.2	0.44	0.11
Silver	33	30	33	NC	NC	NC	NC	NC	NC
Vanadium	NC	NC	NC	--	--	--	--	--	--
Zinc	5.4	7.2	--	2.06	2.84	3.46	5.33	4.42	4.72
1,1-Dichloroethane	--	--	--	NC	NC	NC	NC	NC	NC
1,1-Dichloroethene	0.004	0.001	0.003	NC	NC	NC	NC	NC	NC
Trichloroethene	--	--	--	0.00	0.00	0.00	0.00	0.00	0.00
Water hardness (mg/L CaCO ₃)	111	38	3.5	NC	NC	NC	NC	NC	NC

Notes:

-- means no toxicity reference value available.

Shaded value means hazard quotient exceeds 1.0.

NC means not a chemical of concern for this area.

CaCO₃ - calcium carbonate

The future movement of organic chemicals in the groundwater at Area 6 currently poses the most significant human health risk at the site, because it could potentially affect nearby drinking and agricultural water supplies. Future chemical infiltration, known as leachate, from the landfill operations area into groundwater in Area 6 is possible. The production of leachate poses a potential health risk to future hypothetical groundwater users.

Remedial action for the groundwater is appropriate for the following reasons:

- Water is infiltrating through the landfill operations area causing migration of leachate to the shallow groundwater.
- Data indicate that groundwater containing elevated concentrations of volatile organic compounds is migrating toward the south.
- Continued spread of this contaminated groundwater may affect drinking water.
- The excess cancer risk associated with the reasonable maximum groundwater exposure from the Area 6 shallow aquifer is estimated to be 3 in 100. This risk exceeds the EPA acceptable risk range of 1 in 10,000 to 1 in 1,000,000.

Contaminated groundwater below the former hazardous waste storage area will be remediated. The former hazardous waste storage area will not be capped, because volatile organic compounds have already leached through the soils into the groundwater. Therefore, the soils at the former hazardous waste storage area do not pose a risk to human health.

The goals of the final remedial action are the following:

- Reduce concentrations of contaminants that have already migrated into the shallow aquifer with the ultimate goal of meeting state and federal drinking water standards at point of compliance locations
- Prevent the further spread of volatile organic compounds in the shallow aquifer and treat extracted water to meet state and federal standards prior to discharge
- Reduce the potential risk to existing and future groundwater users located downgradient of the site

- Minimize infiltration of rainwater in the Area 6 landfill operations area to prevent leachate generation and migration into the groundwater
- Prevent potential impacts to downgradient surface water bodies and aquatic organisms as a result of stormwater erosion of the surface soils at the Area 6 landfill operations area
- Prevent further migration of contaminated groundwater across the site boundary and into the lower aquifers
- Prevent exposure to contaminants within subsurface soil and debris in the landfill operations area

Groundwater cleanup standards have been established to meet state and federal requirements. These standards are based on MTCA Method B and are summarized in Table 17.

The "cleanup levels" in Table 17 are based on the protection of human health, assuming Area 6 groundwater is ingested as drinking water. The "compliance levels" take into account analytical considerations and will be re-evaluated during the 5-year reviews. As a result of these reviews, the use of improved analytical techniques with lower practical quantitation limits may be required. In addition, the cumulative excess cancer risk associated with the site will be reduced to, at most, 1×10^{-5} , consistent with MTCA.

MTCA establishes "points of compliance" where groundwater compliance levels must be attained. Compliance levels for the shallow aquifer are shown in Table 17. Usually the groundwater compliance levels must be attained throughout the plume. However, where hazardous substances remain on site as part of the cleanup action, a "conditional point of compliance" can be established that must be as close as practicable to the source of the contamination. The compliance levels must be attained from the conditional point of compliance to the outer boundary of the plume.

Conditional points of compliance must be established for the former hazardous waste storage area. Levels of trichloroethane and trichloroethene in wells N6-37 and N6-38 suggest that NAPL residuals may be present in the aquifer at or near the water table in the former hazardous waste storage area. It may not be practicable to clean up the groundwater directly beneath the former hazardous waste storage area, because there is no way to remove NAPL residual oils if they are indeed there. In addition, the boundary of the former hazardous waste storage area is not clearly defined. Therefore, for the shallow aquifer groundwater, the conditional points of compliance for trichloroethene, trichloroethane, 1,1-dichloroethene, 1,1-dichloroethane, and 1,2-dichloroethene will be no greater than the circumference of a circle centered on a point halfway between wells N6-37 and N6-38 and not to exceed the western property boundary (see Figure 7). Wells

Table 17
Groundwater Cleanup Levels for Operable Unit 1, NAS Whidbey

Parameter	Cleanup Level ($\mu\text{g/L}$)	Rationale	Risk at Cleanup Level	Toxic Effects at Cleanup Level	Compliance Level ($\mu\text{g/L}$)	PQL*
Trichloroethene	5	MCL	1.3×10^{-6}	--	5	0.1
1,1,1-Trichloroethane	200	MCL	--	0.28 ^b	200	0.03
1,1-Dichloroethane	800	MTCA B	--	0.006 ^c	800	0.03
1,1-Dichloroethene	0.07	MTCA B	1×10^{-6}	0.001 ^b	0.07	0.03
1,2-Dichloroethene ^d	70	MCL	--	0.875 ^e	70	0.02
Vinyl chloride	0.02	MTCA B	1×10^{-6}	--	0.1	0.1
Total risk/effects			3×10^{-6}	1.162	8×10^{-6}	

^aPQL - practical quantitation limit (EPA Method 502.1)

^bHepatotoxicity; total hazard quotient = 0.33

^cOther toxicity; total hazard quotient = 0.006

^dCis isomer

^eHemotoxicity; total hazard quotient = 0.875

Notes:

Cleanup levels are defined by ARARs.

Compliance levels take into account that currently available analytical instruments/methods have higher detection limits than the ARAR for vinyl chloride.

$\mu\text{g/L}$ - micrograms per liter

MCL - maximum contaminant level

MTCA B - Model Toxics Control Act Method B

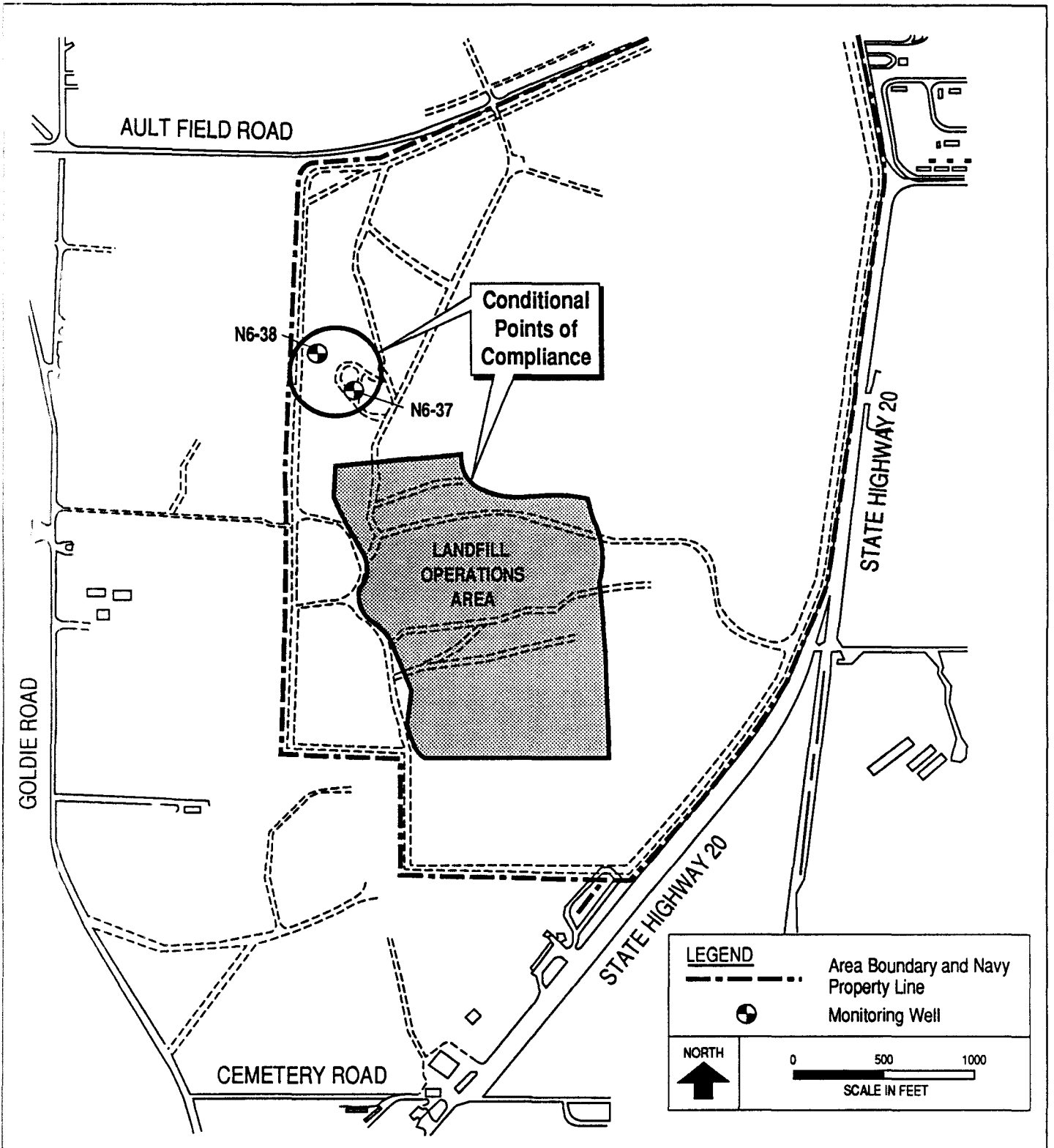

CLEAN
 COMPREHENSIVE LONG-
 TERM ENVIRONMENTAL
 ACTION NAVY

Figure 7
Conditional Points of Compliance

CTO 0005
 OPERABLE UNIT 1
 NAS WHIDBEY, WA
 ROD

N6-37 and N6-38 were selected, because they are located at the suspected source area and have the highest concentrations of trichloroethene and trichloroethane, respectively. If trichloroethene or trichloroethane levels in additional wells installed outside this area during the remedial action indicate the presence of NAPL residuals, these points of compliance will be adjusted at the 5-year review.

Conditional points of compliance for vinyl chloride will be the perimeter of the landfill operations area, because it corresponds to the edge of the source area.

8.2 Area 5

The Navy will conduct additional sampling and monitoring to determine whether metals levels are consistent with background or elevated above levels of concern for human health. If levels exceed background, EPA, Ecology, and the Navy will evaluate the results and jointly determine what additional actions may be necessary.

Ecological risk was identified for the sediments and surface water in the wetlands adjacent to Area 5. However, no source area was located and remedial action could cause more environmental harm than the low levels of existing chemicals are likely to cause.

9.0 DESCRIPTION OF ALTERNATIVES

9.1 Alternatives for Area 6

The feasibility study assessed the alternatives for remediation of Area 6. A total of four alternatives were evaluated for possible implementation at Area 6:

- Alternative 1 - No Action
- Alternative 2 - Institutional Controls
- Alternative 3 - Groundwater Extraction and Treatment by Air Stripping and Capping Landfill Operations Area With Minimum Functional Standards (MFS) Cap
- Alternative 4 - Groundwater Extraction and Treatment by Air Stripping and Capping Landfill Operations Area With Resource Conservation and Recovery Act (RCRA) Cap

Alternatives 3 and 4 incorporate the interim action extraction and treatment system currently under construction, which is expected to be operational and pumping by the

spring of 1994. The interim action involves the extraction, treatment, and discharge of the treated Area 6 groundwater into the shallow aquifer. The extraction system consists of seven wells that will pump groundwater at a combined rate of approximately 170 gallons per minute.

The treatment system consists of an air stripper to remove volatile organic compounds from the groundwater. The remedial design for the air stripper will determine whether the water, before entering the air stripper, must pass through a filter system to remove iron and manganese, which would otherwise hinder the performance of the air stripper. The air stripper causes volatile organic compounds to vaporize into the air. These compounds will be released to the atmosphere only if air emission standards are achieved. If the emission standards are not achieved, additional air pollution control devices will be installed.

The treated groundwater, which will meet federal and state cleanup standards, will be returned to an infiltration/recharge system on the eastern boundary of Area 6. This treated water will infiltrate through the soils into the shallow aquifer.

9.1.1 Alternative 1—No Action

Alternative 1 is included for comparison purposes. This alternative would not require any action at Area 6. It also assumes that the interim action will not be implemented. The feasibility study report concluded that this alternative would not sufficiently protect human health and the environment because of the potential for continued migration of volatile organic compounds in shallow groundwater.

Capital cost	\$0
Present worth of operations and maintenance costs	\$0
Total	\$0

9.1.2 Alternative 2—Institutional Controls

Alternative 2, institutional controls, could prevent or reduce exposure to chemicals of concern on the site. Alternative 2 actions include a groundwater monitoring program, fencing, posting of signs, and permanent restrictive covenants on future property deeds to prevent development of the municipal landfill site or use of the groundwater below the site. The Navy is continuing to provide connections to an alternate water supply to private well owners in the vicinity of Area 6. Alternative 2 also includes providing an alternate water supply. Other institutional controls that will be implemented include restrictions preventing future well installation within or near the groundwater contaminant plume. Alternative 2 assumes that the interim action will not be implemented.

Access to Area 6 is currently restricted; it is enclosed by a fence that is periodically patrolled. The landfill operations area and former hazardous waste storage area within Area 6 currently are not fenced. Alternative 2 actions would involve the construction of a fence around the landfill operations area and the former hazardous waste storage area to secure and restrict access. Signs posted at regular intervals and at the gates would warn people of potential health threats. These restrictions could be maintained as long as the federal government owns the property.

Because the federal government owns the Area 6 property, deed restrictions would be implemented only if the station were closed. Deeds would then include restrictive covenants written into the landfill property deed notifying potential purchasers that the land was used for waste disposal and that land use and water rights are restricted.

The feasibility study report concludes that institutional controls alone would not sufficiently protect human health and the environment at Area 6, because volatile organic compounds in the groundwater may continue to migrate towards the site boundary.

Capital cost (institutional controls)	\$131,000
Present worth of operations and maintenance costs (based on \$131,000 per year for 10 years discounted at 5 percent per year)	\$1,016,000
Total	\$1,147,000

9.1.3 Alternative 3—Groundwater Extraction and Treatment by Air Stripping and Capping Landfill Operations Area With MFS Cap

Alternative 3 includes (1) the interim action, which consists of extracting, treating, and returning treated Area 6 groundwater to the shallow aquifer; (2) capping the Area 6 landfill operations area with an MFS (or equivalent) cap in accordance with Washington State MFS regulations; (3) monitoring the groundwater in the shallow, intermediate, and deep aquifers; (4) providing institutional controls; and (5) monitoring private wells.

An MFS cap is the cap design typically used when closing municipal landfills in the state of Washington. The entire landfill operations area (approximately 40 acres) would be capped. It is not known how much waste was disposed of in the landfill.

The cap minimizes production of leachate by preventing rainwater from coming in contact with the wastes. Layers of the cap typically include coarse sand with gas vents over the fill, an impermeable flexible membrane layer, a drainage layer of high-permeability sand/gravel materials, and topsoil to provide a growth medium for vegetative cover. The gas venting system will allow gases generated by the

decomposition of landfill wastes to be released to the air, preventing potential explosion hazards. All vented gases will meet air emission standards.

Institutional controls associated with this alternative include fencing and signs to restrict access to Area 6. In addition, restrictions will prevent future installation of water supply wells within or near the groundwater contaminant plume. Should Area 6 become private property, deed restrictions would also be required in order to prevent future intrusive excavations within the capped area. It is not known how long the extraction and treatment system will have to operate before remediation goals are met because of the uncertainties associated with the site at this time.

Capital cost (cost of MFS cap, extraction and treatment system, monitoring program)	\$12,064,000
Present worth of operations and maintenance costs (based on \$799,000 per year for 10 years discounted at 5 percent per year)	\$6,170,000
Total	\$18,234,000

9.1.4 Alternative 4—Groundwater Extraction and Treatment by Air Stripping and Capping Landfill Operations Area With RCRA Cap

Alternative 4 includes the same groundwater and private well monitoring, institutional controls, and groundwater extraction, treatment, and return components described for Alternative 3. The only difference between Alternative 3 and Alternative 4 is that Alternative 4 includes capping the municipal landfill with a cover that satisfies the RCRA program's regulatory requirements and design guidance for closure of hazardous waste land disposal facilities. A RCRA cap is typically used to cap areas that contain hazardous wastes regulated under the RCRA program, which is not the case for the Navy landfill operations area in Area 6. Typically the RCRA cap consists of a sand layer over the fill, at least 24 inches of compacted clay soil, an impermeable flexible geomembrane liner, a drainage layer composed of sand and gravel, and a soil layer to provide a growth medium for vegetative cover. The difference between the RCRA cap and the MFS cap described in Alternative 3 is a 2-foot layer of clay under the impermeable flexible membrane liner. The duplicate low-permeability layers provide added protection in case one layer develops a leak. The gas venting system will allow gases generated by the decomposition of landfill wastes to be released to the air, preventing potential explosion hazards. All vented gases will meet air emission standards.

Capital cost (cost of RCRA cap, extraction and treatment system, monitoring program)	\$15,960,000
Present worth of operations and maintenance costs (based on \$899,000 per year for 10 years discounted at 5 percent per year)	\$6,942,000
Total	\$22,902,000

9.2 Alternatives for Area 5

Remedial alternatives for Area 5 were not evaluated in the feasibility study despite the fact that some exceedances of the EPA's AWQC had been detected in surface water during the remedial investigation. No action at Area 5 was deemed appropriate, because intrusive remedial action would likely cause more environmental harm than would the low concentrations of chemicals actually present.

Since the completion of the feasibility study, some human health risk, primarily associated with manganese, has been identified in the shallow groundwater in Area 5. However, because there are uncertainties associated with the data and the remedial investigation results are inconclusive, the Navy will conduct additional monitoring to further characterize the metals concentrations. The additional monitoring will use a low-flow sampling method to reduce turbidity at a cost of approximately \$8,500 to \$20,000 for one to five rounds of sampling for six wells.

10.0 COMPARATIVE ANALYSIS OF ALTERNATIVES

Nine criteria established by EPA were used to evaluate the four remedial alternatives and identify a preferred alternative.

- Overall protection of human health and the environment
- Compliance with ARARs
- Long-term effectiveness and permanence
- Reduction of toxicity, mobility, and volume through treatment
- Short-term effectiveness
- Implementability
- Cost
- State acceptance
- Community acceptance

The following analysis for Area 6 briefly reviews and compares each of the alternatives with the evaluation criteria.

10.1 Overall Protection of Human Health and the Environment

Area 6 poses two risks. The first and primary risk is the potential for chemicals from the former hazardous waste storage area that are already present in the shallow aquifer to migrate farther away from this area. Future potential ingestion of affected groundwater is the primary exposure pathway associated with the site. Alternatives 1 and 2 would not adequately address this threat, because the potential for exposure via this pathway would continue to exist. Implementation of these alternatives would not adequately protect human health or the environment and would preclude the already selected interim action.

By contrast, Alternatives 3 and 4 are considered protective of human health and the environment. They incorporate the interim action and treat the extracted groundwater to meet state and federal standards.

The second risk associated with Area 6 is the potential for leachate to be generated from rainwater infiltrating the landfill operations area. The leachate may then migrate to groundwater. Alternatives 3 and 4 provide capping as part of the remedial alternative to minimize this risk.

Although the cap specified in Alternative 3 is protective of human health and the environment, the cap specified in Alternative 4 is somewhat more protective, because it has an additional low-permeability layer.

10.2 Compliance With ARARs

Neither Alternative 1 nor Alternative 2 addresses remediation of the affected groundwater. Accordingly, these alternatives would not comply with chemical-specific ARARs that are used in addition to the risk assessment results to gauge protectiveness (e.g., drinking water and groundwater criteria specified in the Safe Drinking Water Act and MTCA). These ARARs are applicable to aquifer restoration and reintroduction of treated groundwater to the shallow aquifer. Because these alternatives do not meet the threshold criteria of protectiveness, they are eliminated from further evaluation.

Alternatives 3 and 4 would be required to meet state and federal standards for extracted groundwater, as well as air and water discharge requirements. They would also be required to meet landfill closure requirements. Alternatives 3 and 4 are considered equivalent in terms of the threshold criteria (i.e., each alternative protects human health and the environment and complies with ARARs).

10.3 Long-Term Effectiveness and Permanence

Alternative 3 and Alternative 4 exhibit a high degree of long-term effectiveness and permanence; air strippers typically have removal efficiencies of 95 to 99 percent. Both alternatives include reliable, commonly used groundwater extraction equipment that should operate effectively until aquifer remediation is complete. Both alternatives would be effective in the long term in mitigating risks associated with groundwater.

The RCRA cap specified in Alternative 4 may be considered somewhat more effective in reducing infiltration than the MFS cap specified in Alternative 3 because of its slightly lower permeability. However, the difference in permeability would not significantly affect the effectiveness or duration of the groundwater treatment component of these alternatives.

Both caps effectively reduce infiltration of rainwater into the landfill contents, thereby minimizing production of leachate and contamination of the aquifer. Both caps effectively eliminate concerns associated with contact/ingestion of landfill contents and associated soils. Proper maintenance would be required to ensure the effectiveness of either cap in the long term.

Alternatives 3 and 4 are considered equivalent in terms of this criterion.

10.4 Reduction of Toxicity, Mobility, and Volume Through Treatment

The groundwater treatment system that is being constructed under the interim action and is incorporated into the final remedial action as part of Alternatives 3 and 4, will remove volatile organics from the groundwater. Groundwater will be treated by air stripping with a removal efficiency of 95 to 99 percent. Although air stripping results in a transfer of contaminants from one medium to another (groundwater to air), it is considered treatment.

It is considered too costly and technically infeasible to excavate the landfill and treat the associated soils or dispose of them off site. Therefore, Alternative 3 and Alternative 4 rely on containment of landfill contents and soils as a principal component. Alternatives 3 and 4 are equivalent in terms of this criterion.

10.5 Short-Term Effectiveness

In terms of short-term effectiveness, Alternative 3 and Alternative 4 are similar. Some particulate emissions are expected to occur during the installation of the cap under either alternative. However, dust control methods would reduce this risk. Other potential exposures may result from contact with groundwater during extraction well installation and treatment plant shakedown activities. Additional risks would include

physical hazards associated with construction. Careful implementation of site-specific safety protocols would effectively minimize these risks.

Although the estimated times required to construct the cap for Alternative 3 and Alternative 4 are comparable (approximately 8 months), the estimated construction time for the RCRA-type cap is approximately 2 months longer than for the MFS cap.

The extraction and treatment system will contain the plume immediately upon commencement of the pumping system. Aquifer restoration will require many years of pumping.

10.6 Implementability

Alternative 3 and Alternative 4 incorporate demonstrated technologies (e.g., capping and air stripping) that are commonly applied to landfills and groundwater. Both alternatives are considered readily implementable; no unusual construction difficulties are anticipated. Although permits are not required under CERCLA, the substantive requirements of permits must be met. There are no significant administrative impediments for identification of these substantive requirements. These alternatives consist of technologies that have proved reliable in similar previous applications. All necessary equipment and specialists are readily available.

10.7 Cost

The estimated cost of Alternative 3 is \$18 million. The estimated cost of Alternative 4 is \$23 million, which, in today's dollars, over 10 years exceeds the estimated cost of Alternative 3 by approximately 28 percent.

10.8 State Acceptance

Ecology concurs with the selection of the final remedial alternative for both Areas 5 and 6. Ecology has been involved with the development and review of the Remedial Investigation, Feasibility Study, Proposed Plan, and Record of Decision. Ecology comments have resulted in substantive changes to these documents.

10.9 Community Acceptance

On July 14, 1993, the Navy held a public meeting to discuss the Proposed Plan for final remedial action at OU 1. The results of the public meeting indicated that community members had major concerns about the effect of the Area 6 extraction and treatment system on regional groundwater supplies, protection of groundwater resources, and the proposal to not cap the former hazardous waste storage area. On August 25, 1993, EPA held a public information meeting to further discuss the technical details of the proposed

remedies. There is still some community skepticism about the selected remedy. Community response to the remedial alternatives is presented in the responsiveness summary, which addresses questions and comments received during the public comment period (Appendix A).

11.0 THE SELECTED REMEDY

11.1 Area 6 Remedy

A combination of landfill capping and groundwater control actions is the best way to achieve the broader goal of restoring groundwater in the shallow aquifer to levels that are protective of human health and the environment. The Navy's selected remedy for Area 6 to meet this goal at OU 1 incorporates the interim action remedy (groundwater extraction and treatment by air stripping) and capping the landfill operations area with an MFS cap (Alternative 3). An MFS cap meets regulatory requirements and is protective of human health and the environment. A RCRA cap (Alternative 4) is not necessary, because no RCRA wastes were known to have been disposed of in the landfill operations area.

The major components of the selected remedial action include the following:

- Capping the landfill operations area trenches with an MFS cap
- Assessing the interim action extraction system to ensure that it achieves aquifer cleanup levels and specifically to determine the need for additional source area extraction wells
- Extracting groundwater from the shallow aquifer at the western boundary of the landfill, treating it by air stripping, and returning the treated groundwater to the shallow aquifer at an on-site location
- Monitoring groundwater in the shallow, intermediate, and deep aquifers to assess the effectiveness of the groundwater treatment system
- Monitoring private drinking water wells in the vicinity of the landfill
- Implementing institutional controls

The former hazardous waste storage area will not be capped. Rainwater will continue to infiltrate through the contaminated subsurface soils. Concentrations of volatile organic compounds present in the soils are not sufficient to constitute an unacceptable CERCLA risk. The concentrations are below levels that are considered to be protective of

groundwater (100 x groundwater cleanup levels). The highest concentrations of trichloroethene, 17 parts per billion (ppb), are found at 40 feet below ground surface. Volatile organic compounds have most likely been washed by rainwater into the subsurface soils and into the shallow aquifer. If the former hazardous waste storage area were capped, these chemicals would be trapped in the subsurface soil. Leaving the area uncapped allows the chemicals to continue to be flushed out of the soil by rainwater, washing through the soil into the groundwater, where they will be captured by the groundwater extraction and treatment system. An extraction well will be placed at or near the former hazardous waste storage area to treat the groundwater in this area, which had the highest detected concentrations of volatile organic compounds. The groundwater will be treated to remove volatile organic compounds.

The goal of the Area 6 remedial action is to restore groundwater to its beneficial use, which is, at this site, drinking water. Based on information obtained during the Remedial Investigation and on a careful analysis of all remedial alternatives, EPA, Ecology, and the Navy believe that the selected remedy should be able to achieve this goal. The effectiveness of this remedy and the compliance levels (as established in Table 17) will be re-evaluated at least every 5 years. It may become apparent, during implementation or operation of the groundwater extraction system and its modifications, that contaminant levels have ceased to decline and are remaining constant at levels higher than the remediation goal throughout a portion of the contaminated plume. In such a case, the system performance standards and/or the remedy may be re-evaluated.

The selected remedy will include groundwater extraction. The system's performance will be carefully monitored on a regular basis and adjusted as warranted by the performance data collected during operation. Pumping may be discontinued if there is an impact on nearby private drinking water wells or if it is shown that pumping has resulted in salt water intrusion. Evaluation of the effectiveness of the groundwater extraction system will be ongoing. If progress toward achievement of remedial action goals is not apparent, modifications to the extraction system will be evaluated by the Navy, EPA, and Ecology. Modifications may include any or all of the following:

- Pumping may be discontinued at individual wells where remediation goals have been attained.
- Pumping rates may be varied to eliminate stagnation points.
- Pulse pumping may be incorporated to allow the aquifer to equilibrate and adsorbed contaminants to partition into groundwater.
- Additional extraction wells may be installed to facilitate or accelerate cleanup of the contaminant plume.

- New technologies may be implemented that have been proven to be more effective.
- Additional source control measures may be implemented for the former hazardous waste storage area.

11.1.1 Area 6 Landfill Cap

A low-permeability cap will be placed over the landfill operations trenches. The purpose of the cap is to minimize the migration of contaminants to groundwater by reducing the infiltration of precipitation through the fill areas. The cap will be designed, constructed, and maintained to meet the closure requirements of the State of Washington Minimum Functional Standards for Solid Waste Handling.

Soils and sediments that are not designated as hazardous or dangerous wastes but have been removed as part of remedial actions at other operable units at NAS Whidbey Island may be placed in the Area 6 landfill operations area prior to capping. The placement of the soils and sediments will meet state and federal regulatory requirements and will be subject to public comment as part of the Proposed Plans for the other operable units.

11.1.2 Groundwater Extraction and Treatment by Air Stripping

The goal of the groundwater extraction system is to prevent further migration of contaminated groundwater from the source areas and remediate contaminated groundwater. To accomplish this goal, at least seven extraction wells screened across the entire shallow aquifer will be installed along the western boundary and the western portion of the southern boundary of Area 6. The radial capture zone for each extraction well is projected to be approximately 800 feet. Preliminary calculations indicate that an extraction rate of 24 gallons per minute per well will be necessary to fully contain and remediate the plume.

A metals pretreatment system may be required to ensure that the air stripper operates effectively. After pretreatment, water will pass through the air stripper where volatile organic compounds will be removed from the water and released to the atmosphere. Emissions from the air stripping unit will meet the substantive requirements of state air quality regulations. If necessary, pollution control equipment will be added to the air stripper system.

11.1.3 Groundwater Monitoring—Monitoring Wells

Shallow groundwater in Area 6 will be monitored to assess the effectiveness of the groundwater treatment system. Monitoring will continue throughout operation of the

treatment system. Area 6 monitoring wells in the intermediate and deep aquifers will be monitored to track volatile organic compounds and metals previously detected and to assess the possibility of vertical migration of contaminants. Wells will be monitored for volatile organic compounds, metals, and for salinity. Monitoring parameters and frequency for all aquifers will be determined in the remedial action work plan.

11.1.4 Groundwater Monitoring—Private Drinking Water Wells

Six private drinking water wells close to OU 1 will be monitored every 18 months for volatile organic compounds and salinity. Results will be evaluated after 4.5 years (three sampling events). If no volatile organic compounds are detected and the plume has been contained, monitoring will be discontinued. If volatile organic compounds are detected, potential sources and additional monitoring will be evaluated.

11.1.5 Institutional Controls

The selected remedy for Area 6 will include institutional controls such as restricting access, preventing installation of on-site drinking water wells, and attaching restrictions to any future property deed. These controls will minimize human exposure to the contaminants that will remain on site. Periodic public meetings and press releases will be prepared to inform the public about any issues or concerns regarding OU 1.

11.2 Area 5

The Navy will monitor groundwater in the shallow aquifer for metals no later than 6 months after the ROD is signed. No further action is required for soils, sediments, or surface water at Area 5.

Area 5 monitoring wells will be selected based on proximity to the excavation area. Area 5 monitoring wells will be monitored for metals using low-flow sampling techniques to determine whether on-site metals concentrations are at or below natural background concentrations. Results will be evaluated after the first sampling event. If metals concentrations are at or below background levels, monitoring will be discontinued. If metals concentrations are above background and levels established for the protection of human health, EPA, Ecology, and the Navy will evaluate the data and determine necessary further actions. These may include, but are not limited to, institutional controls, such as restrictions preventing the use of the shallow groundwater, or further monitoring to assess trends in metals concentrations.

12.0 STATUTORY DETERMINATIONS

Under CERCLA Section 121, selected remedies must be protective of human health and the environment, comply with ARARs, be cost-effective, and use permanent solutions and alternative treatment technologies or resource recovery technologies to the maximum extent practical. In addition, CERCLA includes a preference for remedies that use treatment that significantly and permanently reduces the volume, toxicity, or mobility of hazardous wastes as their principal element. The following sections discuss how the selected remedy for Area 6 meets these statutory requirements.

12.1 Protection of Human Health and the Environment

The selected final remedial action for Area 6 protects human health and the environment through source and groundwater controls. Implementation of this remedial action will not pose unacceptable short-term risks for site workers or nearby residents. Installation of the landfill cap will prevent direct exposure to contaminants within the landfill and will minimize the migration of contaminants to the groundwater. The cap will provide long-term effectiveness through operation and maintenance activities.

The groundwater extraction and treatment system will prevent migration of the contaminant plume and permanently remove contaminants from the groundwater. Contaminants will be transferred from groundwater to the air stripper.

12.2 Compliance With ARARs

The selected remedy for Area 6 will comply with federal and state ARARs that have been identified. No waiver of any ARAR is being sought or invoked for any component of the selected remedy. The ARARs identified for the OU 1 site include, but are not limited to, those discussed in the following sections.

12.2.1 Action-Specific ARARs

- Requirements of the State of Washington for water well construction as set forth in Chapter 18.104 RCW (Water Well Construction) and codified in WAC 173-160 (Minimum Standards for the Construction and Maintenance of Wells) and WAC 173-162 (Regulation and Licensing of Well Contractors and Operators) are applicable, because they establish criteria for the construction and maintenance of extraction wells.
- Requirements of the State Underground Injection Control Program (WAC 173-218) as approved under the Safe Drinking Water Act are applicable, because they set forth the procedures and practices for the injection of fluids through wells into the waters of the state and specify that all known available and reasonable

methods of prevention, control, and treatment be used to preserve and protect underground sources of drinking water.

- State of Washington requirements for hazardous waste operations conducted at uncontrolled hazardous waste sites, as set forth in WAC 296-62 (Part P), are applicable because they establish occupational health standards and safe operating procedures.
- Federal Clean Water Act requirements for design standards for wastewater treatment plants (40 C.F.R. part 133) are applicable to the construction of the wastewater treatment plant.
- The Water Pollution Control Act (Chapter 90.48 RCW) and the Water Resources Act of 1971 (Chapter 90.54 RCW) are applicable, because they require the use of all known and reasonable methods for controlling discharges to surface water and groundwater.
- State of Washington requirements for fugitive emissions (WAC 173-400-075) are applicable, because they establish emissions standards for sources emitting hazardous air pollutants and apply in this instance to the handling of material during construction and operation.
- State of Washington Dangerous Waste Regulations (WAC 173-303) are applicable, because they establish standards for the handling, storage, and disposal of investigation-derived waste.
- The Resource Conservation and Recovery Act (RCRA) Subtitle D (40 C.F.R. part 258, subpart F) establishes applicable federal standards for the closure and post-closure care of nonhazardous solid waste landfills.
- WAC 173-351, a revised version of WAC 173-304, reflects recent federal Subtitle D requirements and specifies relevant and appropriate requirements for Minimum Functional Standards for cap designs.
- The State of Washington Hazardous Waste Cleanup—Model Toxics Control Act (MTCA; Chapter 70.150D RCW) is applicable, because it establishes cleanup standards for facilities where hazardous substances have come to be located as codified in Chapter 173-340 WAC, and for determining compliance monitoring requirements.
- The Noise Control Act (42 U.S.C. 4910; 70.107 RCW) is applicable for the design of the air stripper system.

- The State Waste Discharge Permit Program (WAC 173-216), which governs nonpermitted discharges or injection to groundwater, is applicable, because groundwater will be reintroduced to the shallow aquifer via vertical drains.

12.2.2 Chemical-Specific ARARs

- General Regulations for Air Pollution Sources (WAC 173-400-075) are applicable, because they establish emission standards for vinyl chloride and other hazardous air pollutants.
- The State of Washington Hazardous Waste Cleanup—Model Toxics Control Act (MTCA; Chapter 70.150 RCW) is applicable for determining cleanup standards.
- The Safe Drinking Water Act (40 C.F.R. parts 141, 142, 143) is applicable for determining cleanup levels.
- Controls for New Sources of Toxic Air Pollutants (WAC 173-460) are applicable to the design of the air stripper system. WAC 173-460-150 lists trichloroethene and vinyl chloride as Class A toxic air pollutants with acceptable source impact levels of 0.8 micrograms per cubic meter ($\mu\text{g}/\text{m}^3$) and $0.023 \mu\text{g}/\text{m}^3$, respectively. To qualify as a small quantity exemption in accordance with WAC 173-460-080, the maximum emission rate would be 50 pounds per year for trichloroethene and 10 pounds per year for vinyl chloride or the acceptable source impact level for the compound. The acceptable source impact level for Class B toxic air pollutants is $2,697.3 \mu\text{g}$ for 1,1-dichloroethane; $2,630.7 \mu\text{g}$ for 1,2-dichloroethene; and $6,327.0 \mu\text{g}$ for 1,1,1-trichloroethane. For these Class B toxic air pollutants to classify as a small quantity emission, the maximum emission rate would be 43,748 pounds per year for each Class B toxic air pollutant or the acceptable source impact level for each compound. WAC 173-460 sections 040 and 050 provide procedures for new sources to demonstrate to permitting authorities that the emissions meet small quantity exemption status. This regulation would be applicable in determining whether the emissions from the groundwater extraction and air stripper treatment action qualify for the small quantity exemption. If the levels of toxic air pollutants exceed the levels that would qualify the source under the small quantity exemption, a notice of construction is required in accordance with WAC 173-400 and WAC 173-460. Although the administrative requirements associated with obtaining a permit are not applicable, the substantive requirements are applicable. The owner of the new source would be required to notify the Northwest Air Pollution Control Agency and install best available control technology for toxics (T-BACT) on the emissions.

12.2.3 Location-Specific ARARs

- The Wetland Protection Act (Executive Order 11990, 40 C.F.R. part 6, Appendix A) is applicable to protect on-site wetlands.
- The Rare and Endangered Species Act (16 U.S.C. § 1531, *et seq.*; 50 C.F.R. parts 200 and 402) is applicable because a bald eagle has been sighted in the area.

12.2.4 Other Criteria, Advisories, or Guidance

There are no other criteria, advisories, or guidance to be considered for the remedial action.

12.3 Cost-Effectiveness

The selected remedy provides overall effectiveness proportionate to its cost. The groundwater extraction system and MFS cap over the landfill operations area provides reasonable value for the associated cost.

12.4 Utilization of Permanent Solutions and Alternative Treatment Technologies

The selected remedy for Area 6 uses permanent solutions and alternative treatment technologies practicable for this site. The remedy treats contaminated groundwater. The risk from groundwater contamination is permanently reduced through treatment without transferring risk to other media. The selected remedy provides the best balance of long-term effectiveness and permanence; reduction in toxicity, mobility, and volume achieved through treatment; short-term effectiveness; implementability; and cost.

12.5 Treatment as a Principal Element

The selected remedy for Area 6 satisfies the statutory preference for treatment by using treatment as a primary method to permanently reduce the toxicity, mobility, and volume of groundwater contaminants.

13.0 DOCUMENTATION OF SIGNIFICANT CHANGES

The Proposed Plan was released for public comment in June 1993. The Proposed Plan identified Groundwater Extraction and Treatment by Air Stripping and Capping with an MFS Cap as the preferred alternative (Alternative 3). The Navy reviewed all written and verbal comments submitted during the public comment period. Upon review of

these comments, it was determined that no significant changes to the selected remedy, as originally identified in the Proposed Plan, were necessary.

Soils and sediments that are not designated as hazardous or dangerous wastes but have been removed as part of remedial actions at other operable units at NAS Whidbey Island may be placed in the Area 6 landfill operations area prior to capping.

Major components of the remedy include the following:

- Capping the Area 6 landfill operations area
- Extracting groundwater from the shallow aquifer beneath the western boundary of the Area 6 landfill, treating it by air stripping (as selected in the interim action ROD dated April 1992), and returning it to the shallow aquifer at an on-site location
- Monitoring groundwater in the shallow, intermediate, and deep aquifers at Area 6
- Monitoring off-site water supply wells within one-half mile of Area 6
- Monitoring groundwater in the shallow aquifer at Area 5 for inorganics
- Implementing institutional controls

Area 5 groundwater may have concentrations of manganese exceeding background and health-based levels. Groundwater in Area 5 will be monitored for metals using low-flow sampling methods. If contamination is confirmed, the Navy, EPA, and Ecology will determine whether additional action is necessary.

STATUTORY DETERMINATIONS

The selected remedies are protective of human health and the environment, in compliance with federal and state requirements that are legally applicable or relevant and appropriate to the remedial action, and cost-effective. This remedy uses permanent solutions and alternative treatment technologies to the maximum extent practicable for OU 1, and satisfies the statutory preference for remedies that employ treatment that reduces toxicity, mobility, or volume as a principal element.

Because these remedies will result in hazardous substances remaining at OU 1 above health-based levels, a review will be conducted within 5 years after commencement of remedial action to ensure that the remedies continue to provide adequate protection of human health and the environment.

Captain R. R. Penfold
Commanding Officer, Naval Air Station Whidbey Island
United States Navy

Date

DECLARATION OF THE RECORD OF DECISION

SITE NAME AND LOCATION

Naval Air Station Whidbey Island, Ault Field
Operable Unit 1, Areas 5 and 6
Oak Harbor, Washington

STATEMENT OF PURPOSE

This decision document presents the selected final remedial action for Operable Unit (OU) 1, one of four operable units, at the Naval Air Station Whidbey Island, Ault Field, Superfund site near Oak Harbor, Washington. The remedies selected in this decision document were developed in accordance with the Comprehensive Environmental Response, Compensation, and Liability Act, as amended by the Superfund Amendments and Reauthorization Act, and, to the extent practicable, the National Oil and Hazardous Substances Pollution Contingency Plan. This decision is based on the administrative record for OU 1.

The United States Navy (Navy) is the lead agency for this decision. The United States Environmental Protection Agency (EPA) approves of this decision and, along with the Washington State Department of Ecology (Ecology), has participated in the scoping of the site investigations and in the evaluation of remedial action alternatives. The State of Washington concurs with the selected remedy.

ASSESSMENT OF THE SITE

Actual or threatened releases of hazardous substances from OU 1, if not addressed by implementing the response action selected in this Record of Decision (ROD), may present an imminent and substantial endangerment to public health, welfare, or the environment. The selected final remedial action incorporates the previously selected interim remedial action for Area 6.

DESCRIPTION OF THE REMEDY

This remedial action addresses the risk to the public posed by volatile organic compounds in leachate and groundwater. The purpose of this action is to reduce the risk associated with the continued spread of the contaminated groundwater plume at Area 6 and remediate the groundwater through two different categories of actions. The first action category is source controls, which are intended to minimize movement of contaminants from the fill material in the landfill to the groundwater and to prevent direct exposure to contaminated subsurface soil and debris. The second action category is groundwater controls, which are intended to prevent further movement of contaminated groundwater across the site boundary and to prevent consumption by area residents of groundwater exceeding maximum contaminant levels. The combination of both source control and groundwater control actions is necessary to achieve the broader objective of restoring contaminated groundwater in the upper aquifer to levels that are safe for drinking.

Signature sheet for the foregoing Naval Air Station Whidbey Island, Ault Field, Operable Unit 1, final remedial action, Record of Decision, between the United States Navy and the United States Environmental Protection Agency, with concurrence by the Washington State Department of Ecology.

Gerald A. Emison
Acting Regional Administrator, Region 10
United States Environmental Protection Agency

Date

Signature sheet for the foregoing Naval Air Station Whidbey Island, Ault Field, Operable Unit 1, final remedial action, Record of Decision, between the United States Navy and the United States Environmental Protection Agency, with concurrence by the Washington State Department of Ecology.

Carol Fleskes
Program Manager, Toxics Cleanup Program
Washington State Department of Ecology

Date

APPENDIX A
RESPONSIVENESS SUMMARY

RESPONSIVENESS SUMMARY

The public comment period on the Proposed Plan for NAS Whidbey Island, Operable Unit 1 (OU 1), was held from June 24, 1993, to August 25, 1993. A public meeting was held on July 14, 1993, to explain the Proposed Plan and solicit public comments. Members of the public and local newspaper media attended the meeting and participated in a discussion following the presentation. The transcript of the formal comments stated at the public meeting is available in the Administrative Record. This appendix is a summary of the responses by the United States Navy (Navy) to items raised in the written comments and to those issues discussed during the public meeting.

The specific requirements for public participation pursuant to the Comprehensive Environmental Response, Compensation, and Liability Act (CERCLA), Section 117(a), as amended by the Superfund Amendments and Reauthorization Act (SARA), include releasing the Proposed Plan to the public. For the interim action, the Proposed Plan was issued on January 3, 1992, and the public meeting was held on January 27, 1992. Landowners included in the water hookup program were sent special mailings informing them of the interim action Proposed Plan. For the final action, the Proposed Plan was issued on June 24, 1993. The public comment period on the final proposed remedial action was extended from July 23, 1993, to August 25, 1993. A public meeting was held July 14, 1993.

In addition to the public meeting, the United States Environmental Protection Agency (EPA) sponsored a public information session on August 25, 1993, to provide more technical details about the remedial investigations at OU 1 and to discuss the rationale for the Navy's proposed actions. As a result of these public comments, some changes to the Proposed Plan have been made and are incorporated into this Record of Decision (ROD).

Documents pertaining to both the interim and final actions were placed in the following information repositories:

Oak Harbor Library
7030 70th N.E.
Oak Harbor, Washington 98277
Phone: (206) 675-5115

NAS Whidbey Island Library (for individuals with base access)
1115 W. Lexington St.
Oak Harbor, Washington 98278-2700
Phone: (206) 257-2702

Sno-Isle Regional Library System
Coupeville Library
788 N.W. Alexander
Coupeville, Washington 98239
Phone: (206) 678-4911

The Administrative Record (see Appendix B for an index) is on file at the following location:

Engineering Field Activity, Northwest
Naval Facilities Engineering Command
1040 N.E. Hostmark Street
Olympic Place 2
Poulsbo, Washington 98370
Phone: (206) 396-5984

Community relations activities have established communication between the citizens living near the site, the Navy, EPA, and the Washington State Department of Ecology (Ecology). Two citizens are members of the technical review committee and have received copies of all draft documents for review. Discussion has been open among the different groups to exchange information and suggestions on the project. The actions taken to satisfy the statutory requirements also provided a forum for citizen involvement and input to the Proposed Plan and ROD.

Approximately 30 comments were received on the Proposed Plan for final remedial action. A summary of the comments, as well as the Navy's responses, follows.

Expansion of Technical Review Committee

Will the Navy expand the technical review committee (TRC) to include representatives from concerned citizen groups? The TRC needs to be phased out and an Implementation Committee formed to serve in an advisory capacity to document that projects are executed per the design agreement. Will the Navy fund the efforts of these review committees?

Two local citizens have served on the TRC throughout the Remedial Investigation and Feasibility Study process for OU 1. These two citizens are volunteers and are not funded by the Navy. Whereas the Navy is unable to fund community review groups, EPA and Ecology grant funds are available.

The Department of Defense (DoD) has adopted recommendations outlined in the Interim Report of the Federal Facilities Environmental Restoration Dialog Committee, February 1993, for increased public participation at federal facility Superfund sites.

NAS Whidbey Island has been selected as one of five naval installations to serve as a "pilot" for expanding the existing TRC. These expanded TRCs will be renamed Restoration Advisory Boards or RABs. RAB members will be nominated by the current TRC membership. This new concept will be developed to improve the process of information exchange and to work with the agencies to ensure that the projects are executed per the agreements. The RAB for NAS Whidbey Island will be set up starting in November 1993, and the first RAB meeting is scheduled for early 1994.

Capping the Former Hazardous Waste Storage Area

Why is the Navy proposing to not cap the former hazardous waste storage area?

During the public comment period the Navy received numerous comments on the issue of capping the former hazardous waste storage area. All commentors felt that this area should be capped. As a result of public concerns, the Navy, EPA, and Ecology thoroughly reevaluated the data to determine the best course of action.

Landfills or land disposal areas are capped to prevent the generation of leachate and to prevent direct contact with contamination. In the Proposed Plan and subsequent public meetings, it may not have been made clear to the public that the contaminant concentrations in the soils in the former hazardous waste storage area do not constitute a dangerous hot spot. The concentrations of volatile organic compounds in the soils are below the established levels for the protection of human health. In this case, the soil data show that volatile organic compounds that may have been present in the former hazardous waste storage area have **already** leached through the soil. Thus, future generation of leachate and continued contamination of groundwater are not a concern in this area, as opposed to the landfill operations area. Most of the chemicals that were stored or disposed of at the former hazardous waste storage area have been washed by rainwater into the subsurface soils and into the shallow aquifer. Therefore, capping the area would not accomplish the objective of preventing the generation of leachate.

Volatile organic compounds are found at varying concentrations in the soils beneath the hazardous waste storage area. The highest concentrations of trichloroethene, 17 parts per billion (ppb) and 40 ppb, are found at 40 feet below the ground surface. Therefore, direct contact with or ingestion of contaminated soil is not a concern in this area. All concentrations in soil in the vicinity of the former hazardous storage area are less than the Washington State Model Toxics Control Act Method B values established for protection of groundwater. If an additional cover were installed over the former hazardous waste storage area, the low concentrations of chemicals would remain in the subsurface soil and would never be remediated. Leaving the area uncapped allows the chemicals to continue to be flushed out of the soil by rainwater washing through the soil column into the groundwater, which is being treated to remove the volatile organic compounds.

One extraction well has been installed in the former hazardous waste storage area to treat the groundwater with the highest concentrations of volatile organic compounds. Additional wells may be installed in the future, if needed. The Navy, EPA, and Ecology agree that, based on the data and all available information, this is the best course of action to take at this time. This decision also provides the Navy with maximum flexibility. If this remedial action is not sufficient, does not work as anticipated, or if viable new technologies become available in the future, the Navy can easily make adjustments that could not be made if a cap were in place. Because the installation of a cap at this time would not provide additional protection to human health or the environment, it represents an unnecessary expenditure of public funds.

Effects of Pumping

There are regional problems with saltwater intrusion into drinking water aquifers. Won't the pumping by the Navy make this problem worse? Won't the pumping cause the aquifer to go dry? Will the pumping draw contamination from the Oak Harbor Landfill or the Melco site?

Site records (drilling logs and cross sections) report that the shallow aquifer, which is the only aquifer that will be pumped, is hydraulically isolated from the sea level aquifer by two confining layers of low-permeability soil and an intervening aquifer. Because the treatment system is designed so that the rate of recharge will equal the rate of pumping, the aquifer will not go dry. Thus, no regional impacts on the aquifers are anticipated from the groundwater extraction system.

It is very difficult to pull water upgradient and, according to groundwater modeling that has been completed for Area 6, the impacts of pumping are not expected to extend significantly in a downgradient direction. Therefore, the pumping should not draw any groundwater from beneath the Oak Harbor Landfill or Melco. Groundwater levels will be monitored during groundwater extraction to ensure that water is not pulled upgradient from these sites. If necessary, pumping rates will be modified. In addition, only low levels of contamination (below health-based criteria) have been found in the shallow aquifer beneath these sites.

Localized pumping and recharge in the shallow aquifer should have no impact on regional groundwater quality. There will be no impact on the direction of groundwater flow within the sea level aquifer, and this action should not create saltwater intrusion problems on northern Whidbey Island. However, because of this public concern, the Navy will monitor for salinity on a regular basis after pumping begins. Area wells will also be monitored for volatile organic compounds and water levels to confirm that the extraction system is not affecting the aquifer beyond the plume area. The extraction system will be monitored closely and if there is any indication of a problem, the system will be shut down until the problems are identified and all options are evaluated.

Location of Recharge Area for Treated Groundwater

The location of the recharge area for treated groundwater is very important. The recharge area should be downgradient at an off-site location to provide a hydraulic barrier.

There are legal and administrative problems associated with placing the recharge area in a downgradient off-site location to help contain the plume. "Implementability" is one of the nine criteria used to evaluate remedial alternatives. Although there might be strong technical arguments to support an off-site location, the Navy has determined that because of the legal difficulties of obtaining access to off-site private property, it would simply not be practical to implement such a course of action.

The location of the recharge area for return of treated water to the shallow aquifer was based on a computer simulation of the groundwater flow regime beneath the landfill and will result in the formation of a groundwater mound that will push landfill contaminants westerly toward the groundwater extraction system. This process is intended to speed the removal of these contaminants from the subsurface soils. The extraction system has been designed to provide for the capture of these contaminants and the plume should not be pushed westward. Monitoring of groundwater levels will be conducted throughout the operation of the extraction system to ensure that this is the case.

Local Seismic Fault

Have you considered the effect of the fault zone along Goldie Road and the high arsenic concentrations that are associated with that fault?

The Navy is familiar with the fault zone mapped by the United States Geological Survey (USGS) that is perpendicular to Goldie Road. Elevated levels of arsenic have been found in the intermediate and deep aquifers, but no water will be extracted from these aquifers. In the shallow aquifer, there is no indication of high arsenic concentrations associated with the fault. However, if arsenic concentrations *were* elevated as a result of the fault or other geological conditions, the concentrations would be considered natural background conditions and the Navy cannot be held responsible for remediation. Based on sampling conducted in December 1992, the groundwater in the shallow aquifer at Area 6 does not have concentrations of arsenic high enough to require treatment.

Expansion of Area of Investigation

The Melco facility and Oak Harbor Landfill should be included in the investigation of OU 1. A three-dimensional model should be developed of the region and the boundaries of the investigation should be dictated by the topographic features defining the drainage basin within which the Area 6 landfill site is located.

Potential Superfund sites go through an extensive investigation and scoring process prior to being listed on EPA's National Priorities List (NPL). In the case of NAS Whidbey Island, the designated Superfund site is Ault Field. The property boundary defines the actual site unless there is evidence that contamination from the Superfund site has moved beyond the property boundary. Nonetheless, the Navy sampled four wells in the Oak Harbor Landfill, which is outside the property boundary. Low concentrations of vinyl chloride were detected in one of these wells. However, it is not clear what the source of that contamination is. This well will be monitored periodically by the Navy during the groundwater cleanup. Both Melco and the Oak Harbor Landfill were investigated by EPA for possible inclusion on the NPL. Neither site was considered a significant source of contamination based on the EPA site investigations (no significant groundwater contamination was found at either site), and neither could be scored as Superfund sites.

Available geologic and hydrogeologic data obtained from the USGS, county agencies, and previous consultant studies were compiled and reviewed to provide a regional view of the environmental setting of the Area 6 landfill. These data were used to extend the investigation beyond the boundaries of the immediate study area. However, the majority of the available data is incomplete or of inconsistent quality to provide an island-wide assessment of groundwater.

The Area 6 landfill site actually straddles a divide between two separate surface water drainage basins. Delineating surface water drainage basins is not necessarily a useful approach in evaluating the regional groundwater system, because the surface water and groundwater divides do not coincide in this area.

Information about the Oak Harbor Landfill and Melco was used in the site evaluation. Geologic logs and groundwater elevations measured in the Oak Harbor wells were used to assess the regional setting of the Area 6 landfill site. Oak Harbor Landfill wells were also sampled during the remedial investigation.

Replacement Source of Potable Water

All wells located within the drainage basin should be replaced with alternative potable water.

Neither the Navy, EPA, nor Ecology has the authority to shut down off-site private wells. When the Navy first identified the possibility that off-site wells may be affected by a contaminated plume, as a preventive measure, the Navy offered well owners hookups to City water at the Navy's expense. This was a voluntary rather than mandatory program, because no private wells were actually contaminated. If a public health threat exists, the state Department of Health may close wells; however, this is not the case at this site.

Out of 15 property owners who were offered free hookups by the Navy, only 6 have accepted the offer.

Area 5 Remedial Action

Area 5 should be explored to include a broader watershed cap. Area 5 needs to be monitored and the Navy should promise to install a cap if the quality of water changes.

A cap is effective only if it is placed over a source of chemical hazards. No source of potential contamination was identified at Area 5 and, therefore, no useful purpose would be served if a cap were installed. Except for manganese in the groundwater, the only chemicals detected that appear to be greater than federal or state standards were in streams in the vicinity of Area 5. Although Area 5 does not pose a health risk, the Navy has proposed to continue to monitor groundwater at Area 5 to further evaluate the concentration of metals. After evaluating the results of the groundwater samples, the agencies will jointly decide whether additional action is necessary.

Cap Design

A Resource Conservation and Recovery Act (RCRA) cap would be more protective than the proposed Washington State Minimum Functional Standards (MFS) cap. Why wasn't a RCRA cap proposed? When will the design of the cap begin?

The landfill operations area operated as a solid waste landfill. There is no conclusive evidence that hazardous wastes were disposed of in this landfill. If there are no wastes that would be subject to RCRA closure requirements, a RCRA cap is not a regulatory requirement for this landfill. However, the Area 6 landfill is required to meet the closure requirements for municipal solid waste landfills, which include an MFS cap. The MFS cap is considered protective for municipal solid waste landfills. Cap design will begin immediately after ROD finalization.

Metals in Groundwater

What criteria will be used to decide whether or not the high metals concentrations are due to background conditions? Why is the Navy going to monitor groundwater?

The criteria for comparison of on-site metals concentrations in groundwater to background is Ecology's *Statistical Guidance for Ecology Site Managers*, which was published in August 1992. This guidance describes statistical methods required for calculating background concentrations. The Navy, Ecology, and EPA agree on the background locations to be sampled.

Historical groundwater sampling was conducted after bailing the wells. Bailing the wells caused high turbidity in the samples that were collected from the wells. Turbidity is a naturally occurring phenomenon, not a result of site operations. The turbid samples were then analyzed by the laboratory for metals. The laboratory analyzes metals in both the water and the suspended particulates. Sampling conducted during December 1992 was accomplished using a different method. Instead of bailing wells, a low-flow pump was used to sample the wells. This sampling method resulted in low-turbidity samples. Chemical analyses of these samples indicated much lower concentrations of metals. Therefore, historical metals results from bailed wells are attributable to suspended particulates and are not indicative of the groundwater quality. For future monitoring, both on-site wells and background wells will be sampled using the low-flow sampling method.

The monitoring that the Navy is proposing is for volatile organic compounds and metals at Area 6 and metals at Area 5. Metals will be monitored at Area 5 with low-flow sampling techniques designed to minimize sample turbidity and to determine whether concentrations of metals are below background levels. Area 6 monitoring will be conducted to determine the effectiveness of the extraction system and to ensure data accuracy.

Groundwater Risk

Why does the Navy state that water from the Area 6 aquifers does not represent an unacceptable human health risk when vinyl chloride exceeds risk levels and maximum contaminant levels (MCLs)?

The Navy has always contended that the groundwater in the shallow aquifer in Area 6 represents a health risk; therefore, the groundwater in the shallow aquifer is going to be remediated. This comment may refer to the intermediate aquifer. Vinyl chloride was detected in one off-site intermediate aquifer well, but in none of the on-site intermediate aquifer wells. The one off-site detection of vinyl chloride in the intermediate aquifer may be an anomaly. The results of the remedial investigation did not provide an explanation for the presence of vinyl chloride in this well. The Navy will continue monitoring that well and conduct a further investigation if the vinyl chloride persists.

Feasibility of Air Stripping

The proposed air stripping technology poses a serious potential of introducing increasing concentrations of at least arsenic back into the groundwater.

High levels of arsenic have not been found in the Area 6 shallow aquifer. If the Navy were to find that there were high concentrations of metals in the extracted groundwater,

metals pretreatment would have to be implemented before air stripping; otherwise, the treatment system would not function properly.

The treated water will have to meet all federal and state standards prior to reintroduction into the groundwater. These standards are protective of human health and the environment. Therefore, the reintroduction of treated water will not pose a threat.

Effectiveness of Air Stripping

What kind of effectiveness of removal can be expected from air stripping? Can you cite comparative studies? How much water will be pumped and how much of the volatile organic compounds will be removed? How much water will be evaporated in the process? How much toxic substance will be released into the atmosphere?

Air stripping is a proven technology that has been successfully applied at several Superfund sites in Washington State and across the country. Current estimates are that an approximate total of 170 gallons per minute will need to be pumped from the well field to provide effective capture and remediation of the contaminant plume. Based on the estimated pumping rate and contaminant concentration in the extraction wells, approximately 5.5 pounds of volatile organic compounds will be removed from the water daily. Using an assumed average temperature and humidity, approximately 3 gallons per hour would evaporate and not be returned to the aquifer. All of the volatile organic compounds removed from the water (approximately 5.5 pounds per day) would be released to the atmosphere. These emissions are significantly less than the emission limits established by the Northwest Air Pollution Control Agency for total hydrocarbons. Calculations of toxic emissions have not been completed; however, all state and federal emission limits will be met.

Consideration of Bioremediation

Was bioremediation considered as an alternative to pumping and treating groundwater? Bioremediation offers a number of advantages and should be evaluated in comparison to the proposed pump and treat system.

Bioremediation was considered during the initial screening of alternatives process as part of the feasibility study for OU 1. While it is true that in situ bioremediation offers a number of advantages, there are also numerous limitations associated with this technology for cleaning up groundwater.

The main reason that bioremediation was not selected for further detailed analysis is that chlorinated solvents (the main contaminants of concern in groundwater at Area 6) are not highly biodegradable and this technology has not shown that it can achieve the

cleanup goals established for groundwater at this site. There are too many uncertainties associated with bioremediation of groundwater and these uncertainties led the Navy to the conclusion that this technology would not be effective in meeting the groundwater cleanup goals.

Request for an Environmental Impact Statement

The Navy should prepare an environmental impact statement (EIS) for actions it plans at OU 1.

The DoD has determined that the CERCLA Superfund process is the functional equivalent of the National Environmental Policy Act (NEPA) process and, therefore, EISs are not required at DoD Superfund sites for proposed cleanup actions. The Department of Justice and EPA agree with DoD's position.

Cost Information

How much money has been spent to date for investigations at OU 1? How much of the money spent to date has been paid to URS Consultants, Inc.? How much money will be spent in Island County?

Approximately \$6,015,000 has been spent to date for investigations at OU 1. URS Consultants, Inc., (URS) and its contractors have received approximately \$4,815,500 for investigations at OU 1. The amount of money spent in Island County cannot be accurately determined without evaluating the expenditures of several contractors over a period of 10 years. However, the amount is relatively small and would likely be less than 10 percent of the total cost of the project.

Contractor Selection Information

How and when did the Navy choose URS as its consultant? What criteria were used? What other consulting firms were considered? Did EPA or Ecology have any input into the contractor selection process?

URS was awarded the Comprehensive Long-Term Environmental Action Navy (CLEAN) contract for the Navy's northwest region in June 1989. The award was the result of a technical competition for engineering services conducted in accordance with the requirements of the Brooks Bill.

Contractors responding to the contract announcement were evaluated by a board based on an "Evaluation Criteria Outline." The outline consisted of three categories: technical evaluation criteria, management evaluation criteria, and geographical considerations. Criteria that were evaluated for the first two categories are as follows.

Technical Evaluation Criteria:

- Environmental engineering experience
- Key technical personnel
- Staff in appropriate disciplines

Management Evaluation Criteria:

- Corporate management
- Management plan
- Ability to surge
- Construction management approach
- Management and control systems and reports
- Training
- Health and safety program
- Equipment
- Community relations
- Approved contractor's purchasing system
- Volume of previous DoD awards

The contract announcement covered three regions for the Navy and one contract for each of the regions was awarded. A total of 26 firms responded to the announcement for all three regions. Eleven of the firms were eliminated based on a lack of experience. From the remaining 15 firms, 6 were evaluated for the Northwest region contract:

- URS Consultants, Inc.
Seattle, Washington
- Weston Inc.
Westchester, Pennsylvania
- Riedel Environmental Services
Portland, Oregon
- ICF Kaiser
San Francisco, California
- ENSR Corp.
Houston, Texas
- Ebasco Services, Inc.
New York, New York

Neither EPA nor Ecology had any input into the contractor selection decision.

APPENDIX B
ADMINISTRATIVE RECORD INDEX

DECLARATION OF THE RECORD OF DECISION

SITE NAME AND LOCATION

Naval Air Station Whidbey Island, Ault Field
Operable Unit 1, Areas 5 and 6
Oak Harbor, Washington

STATEMENT OF PURPOSE

This decision document presents the selected final remedial action for Operable Unit (OU) 1, one of four operable units, at the Naval Air Station Whidbey Island, Ault Field, Superfund site near Oak Harbor, Washington. The remedies selected in this decision document were developed in accordance with the Comprehensive Environmental Response, Compensation, and Liability Act, as amended by the Superfund Amendments and Reauthorization Act, and, to the extent practicable, the National Oil and Hazardous Substances Pollution Contingency Plan. This decision is based on the administrative record for OU 1.

The United States Navy (Navy) is the lead agency for this decision. The United States Environmental Protection Agency (EPA) approves of this decision and, along with the Washington State Department of Ecology (Ecology), has participated in the scoping of the site investigations and in the evaluation of remedial action alternatives. The State of Washington concurs with the selected remedy.

ASSESSMENT OF THE SITE

Actual or threatened releases of hazardous substances from OU 1, if not addressed by implementing the response action selected in this Record of Decision (ROD), may present an imminent and substantial endangerment to public health, welfare, or the environment. The selected final remedial action incorporates the previously selected interim remedial action for Area 6.

DESCRIPTION OF THE REMEDY

This remedial action addresses the risk to the public posed by volatile organic compounds in leachate and groundwater. The purpose of this action is to reduce the risk associated with the continued spread of the contaminated groundwater plume at Area 6 and remediate the groundwater through two different categories of actions. The first action category is source controls, which are intended to minimize movement of contaminants from the fill material in the landfill to the groundwater and to prevent direct exposure to contaminated subsurface soil and debris. The second action category is groundwater controls, which are intended to prevent further movement of contaminated groundwater across the site boundary and to prevent consumption by area residents of groundwater exceeding maximum contaminant levels. The combination of both source control and groundwater control actions is necessary to achieve the broader objective of restoring contaminated groundwater in the upper aquifer to levels that are safe for drinking.

Major components of the remedy include the following:

- Capping the Area 6 landfill operations area
- Extracting groundwater from the shallow aquifer beneath the western boundary of the Area 6 landfill, treating it by air stripping (as selected in the interim action ROD dated April 1992), and returning it to the shallow aquifer at an on-site location
- Monitoring groundwater in the shallow, intermediate, and deep aquifers at Area 6
- Monitoring off-site water supply wells within one-half mile of Area 6
- Monitoring groundwater in the shallow aquifer at Area 5 for inorganics
- Implementing institutional controls

Area 5 groundwater may have concentrations of manganese exceeding background and health-based levels. Groundwater in Area 5 will be monitored for metals using low-flow sampling methods. If contamination is confirmed, the Navy, EPA, and Ecology will determine whether additional action is necessary.

STATUTORY DETERMINATIONS

The selected remedies are protective of human health and the environment, in compliance with federal and state requirements that are legally applicable or relevant and appropriate to the remedial action, and cost-effective. This remedy uses permanent solutions and alternative treatment technologies to the maximum extent practicable for OU 1, and satisfies the statutory preference for remedies that employ treatment that reduces toxicity, mobility, or volume as a principal element.

Because these remedies will result in hazardous substances remaining at OU 1 above health-based levels, a review will be conducted within 5 years after commencement of remedial action to ensure that the remedies continue to provide adequate protection of human health and the environment.



Captain R. R. Penfold
Commanding Officer, Naval Air Station Whidbey Island
United States Navy

22 Dec 93
Date

Signature sheet for the foregoing Naval Air Station Whidbey Island, Ault Field, Operable Unit 1, final remedial action, Record of Decision, between the United States Navy and the United States Environmental Protection Agency, with concurrence by the Washington State Department of Ecology.

Carol L. Fleskes

Carol Fleskes
Program Manager, Toxics Cleanup Program
Washington State Department of Ecology

Dec. 23, 1993

Date

ENGINEERING FIELD ACTIVITY, NW
NAS WHIDBEY
ADMINISTRATIVE RECORD INDEX

ID #: 243

IB-HEAD: 01.2 BACKGROUND

TITLE: NAVY ASSESSMENT AND CONTROL OF INSTALLATION POLLUTANTS
CONFIRMATION STUDY - VERIFICATION PHASE QA/QC PLAN

DATE: 9/86 # OF PAGES: 36 OPERABLE UNIT: 1
DOCUMENT NUMBER: 1.2-OU1-1 TYPE: REPORT T.O. ACTION:
AUTHOR: SCS ENGINEERS
AUTHOR'S ORG: SCS ENGINEERS

ADDRESSEE: PACNORWESTBRO
ADDRESSEE'S ORG: NAVFACENGCOM, SILVERDALE, WASHINGTON

ID #: 244

SUB-HEAD: 01.2 BACKGROUND

TITLE: HEALTH AND SAFETY PLAN CONFIRMATION STUDY VERIFICATION PHASE

DATE: 1/15/86 # OF PAGES: 56 OPERABLE UNIT: 1
DOCUMENT NUMBER: 1.2-OU1-2 TYPE: REPORT T.O. ACTION:
AUTHOR: SCS ENGINEERS
AUTHOR'S ORG: SCS ENGINEERS

ADDRESSEE:
ADDRESSEE'S ORG:

ID #: 246

SUB-HEAD: 01.2 BACKGROUND

TITLE: CONFIRMATION STUDY VERIFICATION PHASE PLAN OF ACTION FOR
SAMPLING AND ANALYSIS

DATE: 9/86 # OF PAGES: 100 OPERABLE UNIT: 1
DOCUMENT NUMBER: 1.2-OU1-3 TYPE: REPORT T.O. ACTION:
AUTHOR: SCS ENGINEERS
AUTHOR'S ORG: SCS ENGINEERS

ADDRESSEE: PACNORWESTBRO
ADDRESSEE'S ORG: NAVFACENGCOM, SILVERDALE, WASHINGTON

ID #: 247

SUB-HEAD: 01.3 NOTIFICATION/SI/CERCLA

TITLE: NAVAL SHORE ACTIVITY DISPOSAL SITE FACT FORM

DATE: 4/20/83 # OF PAGES: 42 OPERABLE UNIT: 1
DOCUMENT NUMBER: 1.3-OU1-1 TYPE: REPORT T.O. ACTION:
AUTHOR: COMMANDING OFFICER, NAS WHIDBEY
AUTHOR'S ORG: NAS WHIDBEY

ADDRESSEE: NEESA (112N) PORT HUENEME, CA 93043
ADDRESSEE'S ORG: NEESA (112N) PORT HUENEME, CA 93043

ID #: 248

SUB-HEAD: 01.4 PA REPORT
TITLE: INITIAL ASSESSMENT STUDY OF NAS WHIDBEY

DATE: 9/84 # OF PAGES: 270 OPERABLE UNIT: 1
DOCUMENT NUMBER: 1.4-OU1-1 TYPE: REPORT T.O. ACTION:
AUTHOR: SCS ENGINEERS
AUTHOR'S ORG: SCS ENGINEERS

ADDRESSEE: NAVY ASSESS & CONTROL OF INSTALLATION OF POLLUTANT
ADDRESSEE'S ORG: NAVAL ENERGY & ENVIRONMENTAL SUPPORT ACTIVITY

ID #: 226

SUB-HEAD: 01.5 SI REPORT
TITLE: ANALYSIS REPORT

DATE: 3/18/87 # OF PAGES: 49 OPERABLE UNIT: 1
DOCUMENT NUMBER: 1.5-OU1-1 TYPE: REPORT T.O. ACTION:
AUTHOR: AT AM TEST INC
AUTHOR'S ORG:

ADDRESSEE: SCS ENGINEERS
ADDRESSEE'S ORG:

ADD*****

ID #: 106

SUB-HEAD: 01.5 SI REPORT
TITLE: CURRENT SITUATION REPORT

DATE: 1/88 # OF PAGES: 310 OPERABLE UNIT: 1
DOCUMENT NUMBER: 1.5-OU1-2 TYPE: REPORT T.O. ACTION:
AUTHOR: SCS ENGINEERS
AUTHOR'S ORG:

ADDRESSEE: ENGINEERING FIELD ACTIVITY
ADDRESSEE'S ORG:

ID #: 251

SUB-HEAD: 01.5 SI REPORT
TITLE: COMMENTS ON SITE 6 INITIAL INVESTIGATION DRAFT TECHNICAL
MEMORANDUM

DATE: 1/8/90 # OF PAGES: 1 OPERABLE UNIT: 1
DOCUMENT NUMBER: 1.5-OU1-3 TYPE: LETTER T.O. ACTION:
AUTHOR: BOB GOODMAN
AUTHOR'S ORG: DEPARTMENT OF ECOLOGY

ADDRESSEE: LEO VASAITIS
ADDRESSEE'S ORG: EFA, NW

ENGINEERING FIELD ACTIVITY, NW
NAS WHIDBEY
ADMINISTRATIVE RECORD INDEX

ID #: 256

S -HEAD: 01.7 ACTION PLAN
TITLE: COMMENTS ON DRAFT ACTION PLAN

DATE: 4/5/90 # OF PAGES: 4 OPERABLE UNIT: 1
DOCUMENT NUMBER: 1.7-OU1-2 TYPE: LETTER T.O. ACTION:
AUTHOR: BUB LOISELLE
AUTHOR'S ORG: ENVIROMENTAL PROTECTION AGENCY

ADDRESSEE: BRYAN HAELSIG
ADDRESSEE'S ORG: EFA, NW

ID #: 254

SUB-HEAD: 01.7 ACTION PLAN
TITLE: ACTION PLAN NAVAL AIR STATION WHIDBEY ISLAND OAK HARBOR, WA

DATE: 10/19/90 # OF PAGES: 74 OPERABLE UNIT: 1
DOCUMENT NUMBER: 1.7-OU1-3 TYPE: REPORT T.O. ACTION:
AUTHOR: SCIENCE APPLICATIONS INTERNATIONAL CORPORATION
AUTHOR'S ORG: SCIENCE APPLICATIONS INTERNATIONAL CORPORATION

ADDRESSEE: ENGINEERING FIELD ACTIVITY, NORTHWEST
ADDRESSEE'S ORG: EFA, NW

ID #: 3424

SUB-HEAD: 10.1 COMMENTS AND REPSONSES
TITLE: PRESENTING ADDITIONAL INFORMATION FOR THE INTERIM PROPOSAL

DATE: 5/17/93 # OF PAGES: 6 OPERABLE UNIT: 1
DOCUMENT NUMBER: 10.1-OU1-1 TYPE: LETTER T.O. ACTION:
AUTHOR: MICHAEL L. ABBOTT
AUTHOR'S ORG: WILBEE RESEARCH

ADDRESSEE: KATHY SOUDERS/NANCY HARNEY
ADDRESSEE'S ORG: NAS WHIDBEY ISLAND/EPA

ID #: 3314

SUB-HEAD: 10.1 COMMENTS AND REPSONSES
TITLE: COMMENTS ON PROPOSED PLAN

DATE: 7/2/93 # OF PAGES: 1 OPERABLE UNIT: 1
DOCUMENT NUMBER: 10.1-OU1-2 TYPE: LETTER T.O. ACTION:
AUTHOR: CRAIG E. THOMPSON
AUTHOR'S ORG: CITIZEN

ADDRESSEE: HOWARD THOMAS
ADDRESSEE'S ORG: NAS WHIDBEY

ID #: 3315

SUB-HEAD: 10.1 COMMENTS AND REPSONSES
TITLE: COMMENTS ON PROPOSED PLAN FINAL REMEDIAL ACTION PLAN

DATE: 7/9/93 # OF PAGES: 2 OPERABLE UNIT: 1
DOCUMENT NUMBER: 10.1-OU1-3 TYPE: COMMENTS T.O. ACTION:
AUTHOR: WISE (WHIDBEY ISLAND FOR A SOUND ENVIRONMENT
AUTHOR'S ORG:

ADDRESSEE:
ADDRESSEE'S ORG:

ID #: 3406

SUB-HEAD: 10.10 CORRESPONDENCE
TITLE: NOTICE OF A INFORMAL MEETING WITH WISE ORGANIZATION,
WHIDBEY ISLANDERS ON AUG 25, 1993

DATE: 8/11/93 # OF PAGES: 2 OPERABLE UNIT: 1
DOCUMENT NUMBER: 10.10-OU1-1 TYPE: LETTER T.O. ACTION:
AUTHOR: NANCY HARNEY
AUTHOR'S ORG: EPA

ADDRESSEE: MR. BILL SKUBI
ADDRESSEE'S ORG: WISE

* *****

ID #: 3317

SUB-HEAD: 10.11 NEWSPAPER/JOURNAL ARTICLE
TITLE: "SOME QUESTIONS LEFT UNANSWERED AT NAVY CLEANUP PLAN HEARING

DATE: 7/17/93 # OF PAGES: 1 OPERABLE UNIT: 1
DOCUMENT NUMBER: 10.11-OU1-1 TYPE: NEWSPAPER ARTICLE T.O. ACTION:
AUTHOR: DYLAN MC DANNIEL
AUTHOR'S ORG: WHIDBEY NEWS-TIMES

ADDRESSEE:
ADDRESSEE'S ORG:

ID #: 311

SUB-HEAD: 10.4 PUB NOTE OF AVAIL OF INFO
TITLE: TECHNICAL REVIEW COMMITTEE MEETING MINUTES

DATE: 11/16/90 # OF PAGES: 8 OPERABLE UNIT: 1
DOCUMENT NUMBER: 10.3-OU1-1 TYPE: TRANSMITTAL T.O. ACTION:
AUTHOR: K.A. SOUDERS
AUTHOR'S ORG: NAS WHIDBEY

ADDRESSEE: COMMANDING OFFICER
RESSEE'S ORG: EFA, NW

SUB-HEAD: 10.3 TECHNICAL REVIEW COMMITTEE
TITLE: SENDING THE MINUTES OF THE TRC MEETING OF JUNE 15, 1992

ID #: 3638

DATE: 7/9/92 # OF PAGES: 6 OPERABLE UNIT: 1
DOCUMENT NUMBER: 10.3-OU1-10 TYPE: LETTER T.O. ACTION:
AUTHOR: K. A. SOUDERS
AUTHOR'S ORG: NAS WHIDBEY

ADDRESSEE: PAUL MARCHANT
ADDRESSEE'S ORG: WASHINGTON STATE DEPT OF ECOLOGY

ID #: 3643

SUB-HEAD: 10.3 TECHNICAL REVIEW COMMITTEE
TITLE: NOTICE OF TRC MEETING ON 12/10/92

DATE: 11/25/92 # OF PAGES: 1 OPERABLE UNIT: 1
DOCUMENT NUMBER: 10.3-OU1-11 TYPE: LETTER T.O. ACTION:
AUTHOR: K. A. SOUDERS
AUTHOR'S ORG: NAS WHIDBEY

ADDRESSEE: SERGEANT WAYNE LEWIS
ADDRESSEE'S ORG: DEPT OF EMERGENCY SERVICES ISLAND COUNTY COURTHOUSE

ID #: 3648

SUB-HEAD: 10.3 TECHNICAL REVIEW COMMITTEE
TITLE: NOTICE OF TRC MEETING FOR 2/5/93

DATE: 1/7/93 # OF PAGES: 1 OPERABLE UNIT: 1
DOCUMENT NUMBER: 10.3-OU1-12 TYPE: LETTER T.O. ACTION:
AUTHOR: K. A. SOUDERS
AUTHOR'S ORG: NAS WHIDBEY

ADDRESSEE: SERGEANT WAYNE LEWIS
ADDRESSEE'S ORG: DEPT OF EMERGENCY SERVICES ISLAND COUNTY COURTHOUSE

ID #: 3653

SUB-HEAD: 10.3 TECHNICAL REVIEW COMMITTEE
TITLE: NOTICE OF TRC MEETING ON JUNE 30, 1993

DATE: 6/4/93 # OF PAGES: 1 OPERABLE UNIT: 1
DOCUMENT NUMBER: 10.3-OU1-13 TYPE: LETTER T.O. ACTION:
AUTHOR: K. A. SKINNER
AUTHOR'S ORG: NAS WHIDBEY

ADDRESSEE: ALI RAAD
ADDRESSEE'S ORG: WASHINGTON STATE DEPT OF ECOLOGY

ID #: 3658

SUB-HEAD: 10.3 TECHNICAL REVIEW COMMITTEE
TITLE: SENDING THE FINAL FEASIBILITY STUDY FOR OU 1 AND RINAL RI
ON OU 1, 2, AND 4

DATE: 6/29/93 # OF PAGES: 1 OPERABLE UNIT: 1
DOCUMENT NUMBER: 10.3-OU1-14 TYPE: LETTER T.O. ACTION:
AUTHOR: K. A. SOUDERS
AUTHOR'S ORG: NAS WHIDBEY

ADDRESSEE: SERGEANT WAYNE LEWIS
ADDRESSEE'S ORG: DEPT OF EMERGENCY SERVICES ISLAND COUNTY COURTHOUSE

ID #: 3661

SUB-HEAD: 10.3 TECHNICAL REVIEW COMMITTEE
TITLE: NOTICE OF TRC MEETING ON 11/4/93

DATE: 10/18/93 # OF PAGES: 1 OPERABLE UNIT: 1
DOCUMENT NUMBER: 10.3-OU1-15 TYPE: LETTER T.O. ACTION:
AUTHOR: K. J. SKINNER
AUTHOR'S ORG: NAS WHIDBEY

ADDRESSEE: ALI RAAD
ADDRESSEE'S ORG: WASHINGTON STATE DEPT OF ECOLOGY

ID #: 3612

SUB-HEAD: 10.3 TECHNICAL REVIEW COMMITTEE
TITLE: SENDING THE REVISION PACKAGE FOR THE PHASE II FIELDWORK OF
OU 1

DATE: 9/4/91 # OF PAGES: 2 OPERABLE UNIT: 1
DOCUMENT NUMBER: 10.3-OU1-2 TYPE: LETTER T.O. ACTION:
AUTHOR: K. A. SOUDERS
AUTHOR'S ORG: NAS WHIDBEY

ADDRESSEE: ED BOONSTRA
ADDRESSEE'S ORG: CITY OF OAK HARBOR

ID #: 3617

SUB-HEAD: 10.3 TECHNICAL REVIEW COMMITTEE
TITLE: SENDING MINUTES OF THE TECHNICAL REVIEW COMMITTEE MEETING
OF SEPT 25, 91

DATE: 10/2/91 # OF PAGES: 5 OPERABLE UNIT: 1
DOCUMENT NUMBER: 10.3-OU1-3 TYPE: LETTER T.O. ACTION:
AUTHOR: K. A. SOUDERS
AUTHOR'S ORG: NAS WHIDBEY

ADDRESSEE: RICHARD BROOKS
ADDRESSEE'S ORG: SUQUAMISH TRIBAL FISHERIES DEPARTMENT

ID #: 849

SUB-HEAD: 10.3 TECHNICAL REVIEW COMMITTEE
TITLE: TECHNICAL REVIEW MEETING MINUTES

DATE: 10/2/91 # OF PAGES: 8 OPERABLE UNIT: 1
DOCUMENT NUMBER: 10.3-OU1-4 TYPE: REPORT T.O. ACTION:
AUTHOR: COMMANDING OFFICER
AUTHOR'S ORG: NAVAL AIR STATION, WHIDBEY ISLAND

ADDRESSEE: COMMANDING OFFICER
ADDRESSEE'S ORG: EFA, NW

ID #: 3621

SUB-HEAD: 10.3 TECHNICAL REVIEW COMMITTEE
TITLE: INVITING TO PARTICIPATE IN THE 1991 TOXICOLOGY
DEMONSTRATION TECHNICAL WORKSHOP ON NOV 8, 1991

DATE: 10/24/91 # OF PAGES: 1 OPERABLE UNIT: 1
DOCUMENT NUMBER: 10.3-OU1-5 TYPE: LETTER T.O. ACTION:
AUTHOR: K. A. SOUDERS
AUTHOR'S ORG: NAS WHIDBEY

ADDRESSEE: DAVID FYFE
ADDRESSEE'S ORG: NORTHWEST INDIAN FISHERIES COMMISSION

ID #: 3626

SUB-HEAD: 10.3 TECHNICAL REVIEW COMMITTEE
TITLE: NOTICE OF TRC MEETING ON 12/18/91

DATE: 12/6/91 # OF PAGES: 1 OPERABLE UNIT: 1
DOCUMENT NUMBER: 10.3-OU1-6 TYPE: LETTER T.O. ACTION:
AUTHOR: K. A. SOUDERS
AUTHOR'S ORG: NAS WHIDBEY

ADDRESSEE: STAN EELKEMA
ADDRESSEE'S ORG: DEPT OF EMERGENCY SERVICES ISLAND COUNTY COURTHOUSE

ID #: 3631

SUB-HEAD: 10.3 TECHNICAL REVIEW COMMITTEE
TITLE: SENDING DRAFT HAZARDOUS WASTE EVAL STUDY AND RI

DATE: 3/6/92 # OF PAGES: 1 OPERABLE UNIT: 1
DOCUMENT NUMBER: 10.3-OU1-7 TYPE: LETTER T.O. ACTION:
AUTHOR: K. A. SOUDERS
AUTHOR'S ORG: NAS WHIDBEY

ADDRESSEE: RICHARD BROOKS
ADDRESSEE'S ORG: SUQUAMISH TRIBAL FISHERIES DEPT

ID #: 3632

SUB-HEAD: 10.3 TECHNICAL REVIEW COMMITTEE
TITLE: NOTICE OF THE FINAL PRESENTATION OF THE TOXICOLOGICAL
DEMONSTRATION PROJECT

DATE: 4/10/92 # OF PAGES: 1 OPERABLE UNIT: 1
DOCUMENT NUMBER: 10.3-OU1-8 TYPE: LETTER T.O. ACTION:
AUTHOR: K. A. SOUDERS
AUTHOR'S ORG: NAS WHIDBEY

ADDRESSEE: RICHARD BROOKS
ADDRESSEE'S ORG: SUQUAMISH TRIBAL FISHERIES DEPARTMENT

ID #: 3637

SUB-HEAD: 10.3 TECHNICAL REVIEW COMMITTEE
TITLE: SENDING THE DRAFT FEASIBILITY STUDY REPORT FOR OU1

DATE: 7/9/92 # OF PAGES: 1 OPERABLE UNIT: 1
DOCUMENT NUMBER: 10.3-OU1-9 TYPE: LETTER T.O. ACTION:
AUTHOR: K. A. SOUDERS
AUTHOR'S ORG: NAS WHIDBEY

ADDRESSEE: RICHARD BROOKS
ADDRESSEE'S ORG: SUQUAMISH TRIBAL FISHERIES DEPARTMENT

ID #: 3316

SUB-HEAD: 10.5 PUBLIC MEETING TRANSCRIPT
TITLE: PUBLIC COMMENT ON THE PROPOSED PLAN FINAL REMEDIAL ACTION
FOR OU 1

DATE: 7/14/93 # OF PAGES: 7 OPERABLE UNIT: 1
DOCUMENT NUMBER: 10.5-OU1-2 TYPE: COMMENTS T.O. ACTION:
AUTHOR: PUBLIC MEETING
AUTHOR'S ORG:

ADDRESSEE:
ADDRESSEE'S ORG:

ID #: 1169

SUB-HEAD: 10.7 FACT SHEETS AND PRESS REL
TITLE: RESULTS OF SURVEYS AND SAMPLING ADJACENT TO NAVY LAND FILL
KNOWN

DATE: 5/28/91 # OF PAGES: 3 OPERABLE UNIT: 1
DOCUMENT NUMBER: 10.7-OU1-1 TYPE: NEWS RELEASE T.O. ACTION:
AUTHOR: PUBLIC AFFAIRS OFFICE
AUTHOR'S ORG: NAVAL AIR STATION WHIDBEY ISLAND

ADDRESSEE:
ADDRESSEE'S ORG:

ID #: 3038

HEAD: 11.4 TECHNICAL SOURCES
TITLE: REPORT ADDRESSING THE INVESTIGATION OF THE WATER QUALITY OF
DRINKING WATER WELLS IN THE VICINITY OF THE WHIDBEY NAVAL
AIR STATION LANDFILL
DATE: 3/24/93 # OF PAGES: 422 OPERABLE UNIT: 1
DOCUMENT NUMBER: 11.4-OU1-1 TYPE: REPORT T.O. ACTION:
AUTHOR: STEVE HULSMAN
AUTHOR'S ORG: WASHINGTON STATE DEPT OF HEALTH

ADDRESSEE: INTERESTED PARTIES
ADDRESSEE'S ORG:

ID #: 822

SUB-HEAD: 02.1 CORRESPONDENCE
TITLE: SUBMITTAL OF DRAFT INTERIM ACTION PROPOSED PLAN FOR OUI
DATE: 11/25/91 # OF PAGES: 11 OPERABLE UNIT: 1
DOCUMENT NUMBER: 2.1-OUI-1 TYPE: LETTER & ENCLOSUR T.O. ACTION:
AUTHOR: KEVIN STIGILE
AUTHOR'S ORG: EFA, NW

ADDRESSEE: NANCY HARNEY/PAUL MARCHANT
ADDRESSEE'S ORG: EPA/WASHINGTON STATE DEPT OF ECOLOGY

ID #: 3012

SUB-HEAD: 02.1 CORRESPONDENCE
TITLE: CLOSURE REPORT FOR WELL 6-D-4
DATE: 3/1/93 # OF PAGES: 1 OPERABLE UNIT: 1
DOCUMENT NUMBER: 2.1-OUI-2 TYPE: LETTER T.O. ACTION:
AUTHOR: BELA J. VARGA
AUTHOR'S ORG: EFA, NW

ADDRESSEE: NANCY HARNEY/PAUL MARCHANT
ADDRESSEE'S ORG: EPA/WASHINGTON STATE DEPT OF ECOLOGY

ID #: 1152

SUB-HEAD: 02.5 EE/CA
TITLE: PROPOSED PLAN FOR INTERIM ACTION AT NAS WHIDBEY ISLAND

DATE: 12/27/91 # OF PAGES: 8 OPERABLE UNIT: 1
DOCUMENT NUMBER: 2.5-OU1-1 TYPE: LETTER & ATTACHME T.O. ACTION:
AUTHOR: ROBERT YUST
AUTHOR'S ORG: SAIC

ADDRESSEE: BRYAN HAELSIG
ADDRESSEE'S ORG: EFA, NW

ID #: 1153

SUB-HEAD: 02.6 ACTION MEMORANDUM
TITLE: PROPOSED PLAN SUPERFUND INTERIM REMEDIAL ACTION AT AULT
FIELD AREA 6 LANDFILL

DATE: 1/3/92 # OF PAGES: 8 OPERABLE UNIT: 1
DOCUMENT NUMBER: 2.6-OU1-1 TYPE: NOTICE & INFORMAT T.O. ACTION:
AUTHOR:
AUTHOR'S ORG:

ADDRESSEE:
ADDRESSEE'S ORG:

** *****

ID #: 1481

SUB-HEAD: 04.2 ROD
TITLE: DECLARATION OF THE RECORD OF DECISION, DECISION SUMMARY,
RESPONSIVENESS SUMMARY, AND ADMINISTRATIVE RECORD INDEX

DATE: 4/92 # OF PAGES: 52 OPERABLE UNIT: 1
DOCUMENT NUMBER: 2.6-OU1-2 TYPE: REPORT T.O. ACTION:
AUTHOR:
AUTHOR'S ORG:

ADDRESSEE:
ADDRESSEE'S ORG:

ID #: 3014

SUB-HEAD: 02.8 REMEDIATION STUDIES
TITLE: FINAL TECHNICAL MEMORANDUM ABANDONMENT OF WELL 6-D-4

DATE: 2/93 # OF PAGES: 66 OPERABLE UNIT: 1
DOCUMENT NUMBER: 2.8-OU1-1 TYPE: REPORT T.O. ACTION:
AUTHOR: URS
AUTHOR'S ORG:

ADDRESSEE:
ADDRESSEE'S ORG:

ID #: 289

SUB-HEAD: 03.1 CORRESPONDENCE
TITLE: AREAS 5 & 6 INTERIM ACTION DRAFT TECHNICAL MEMORANDUM
COMMENTS

DATE: # OF PAGES: 2 OPERABLE UNIT: 1
DOCUMENT NUMBER: 3.1-OU1-1 TYPE: MEMO T.O. ACTION:
AUTHOR: MATT KLOPE
AUTHOR'S ORG: NAS WHIDBEY ISLAND, WASHINGTON

ADDRESSEE:
ADDRESSEE'S ORG:

ID #: 286

SUB-HEAD: 03.1 CORRESPONDENCE
TITLE: REQUEST FOR EXTENSION THE 30 DAY COMMENT PERIOD FOR THE
WHIDBEY ISLAND NAVAL AIR STATION MANAGEMENT PLAN, OPERABLE
UNIT A FOR AN ADDITIONAL 20 DAYS

DATE: 8/22/90 # OF PAGES: 1 OPERABLE UNIT: 1
DOCUMENT NUMBER: 3.1-OU1-10 TYPE: LETTER T.O. ACTION:
AUTHOR: BUB LOISELLE
AUTHOR'S ORG: ENVIRONMENTAL PROTECTION AGENCY

ADDRESSEE: BRYAN HAELSIG
ADDRESSEE'S ORG: EFA, NW

ID #: 287

SUB-HEAD: 03.1 CORRESPONDENCE
TITLE: SUSPENSION OF THE ENVIRONMENTAL COMPLIANCE GROUP OF SCIENCE
APPLICATIONS INTERNATIONAL CORPORATION (SAIC)

DATE: 9/26/90 # OF PAGES: 2 OPERABLE UNIT: 1
DOCUMENT NUMBER: 3.1-OU1-11 TYPE: LETTER T.O. ACTION:
AUTHOR: CHARLES E. FINDLEY
AUTHOR'S ORG: ENVIRONMENTAL PROTECTION AGENCY, HAZARDOUS WASTE DIVISION

ADDRESSEE: CAPT. DAVID WAGGONER
ADDRESSEE'S ORG: NAS WHIDBEY

ID #: 291

SUB-HEAD: 03.1 CORRESPONDENCE
TITLE: COMMENTS ON OPERABLE UNIT #1 DRAFT MANAGEMENT PLANS

DATE: 10/1/90 # OF PAGES: 35 OPERABLE UNIT: 1
DOCUMENT NUMBER: 3.1-OU1-12 TYPE: LETTER T.O. ACTION:
AUTHOR: BUB LOISELLE
AUTHOR'S ORG: ENVIRONMENTAL PROTECTION AGENCY

ADDRESSEE: BRYAN HAELSIG
ADDRESSEE'S ORG: EFA, NW

ID #: 292

UB-HEAD: 03.1 CORRESPONDENCE
TITLE: ADDITIONAL COMMENTS ON OPERABLE UNIT #1 DRAFT MANAGEMENT PLANS

DATE: 10/2/90 # OF PAGES: 4 OPERABLE UNIT: 1
DOCUMENT NUMBER: 3.1-OU1-13 TYPE: LETTER T.O. ACTION:
AUTHOR: BUB LOISELLE
AUTHOR'S ORG: ENVIRONMENTAL PROTECTION AGENCY

ADDRESSEE: BRYAN HAELSIG
ADDRESSEE'S ORG: EFA, NW

ID #: 293

UB-HEAD: 03.1 CORRESPONDENCE
TITLE: NAS WHIDBEY ISLAND IR PROGRAM COMMENT REGARDING DRAFT RI/FS STUDY OF OPERABLE UNIT A

DATE: 10/3/90 # OF PAGES: 4 OPERABLE UNIT: 1
DOCUMENT NUMBER: 3.1-OU1-14 TYPE: LETTER T.O. ACTION:
AUTHOR: JOYE BONVOULOIR
AUTHOR'S ORG: ISLAND COUNTY HEALTH DEPARTMENT

ADDRESSEE: KATHY SOUDERS
ADDRESSEE'S ORG: NAS WHIDBEY ISLAND, WASHINGTON

ID #: 294

UB-HEAD: 03.1 CORRESPONDENCE
TITLE: HUMAN HEALTH RISK ASSESSMENT COMMENT OPERABLE UNIT #1

DATE: 10/4/90 # OF PAGES: 3 OPERABLE UNIT: 1
DOCUMENT NUMBER: 3.1-OU1-15 TYPE: LETTER T.O. ACTION:
AUTHOR: BARRY ROGOWSKI
AUTHOR'S ORG: WASHINGTON STATE DEPARTMENT OF ECOLOGY

ADDRESSEE: BRYAN HAELSIG
ADDRESSEE'S ORG: EFA, NW

ID #: 223

UB-HEAD: 03.1 CORRESPONDENCE
TITLE: COMMENTS OF AREAS 5 & 6 DRAFT FIELD SAMPLING PLAN

DATE: 10/5/90 # OF PAGES: 4 OPERABLE UNIT: 1
DOCUMENT NUMBER: 3.1-OU1-16 TYPE: REPORT T.O. ACTION:
AUTHOR: MR. PETER VOGLE
AUTHOR'S ORG: GROUND WATER MANAGEMENT COMMITTEE

ADDRESSEE:
ADDRESSEE'S ORG:

ENGINEERING FIELD ACTIVITY, NW
NAS WHIDBEY
ADMINISTRATIVE RECORD INDEX

ID #: 267

B-HEAD: 03.1 CORRESPONDENCE
TITLE: TRANSMITTAL OF THE SEISMIC SURVEY EVALUATION

DATE: 10/19/90 # OF PAGES: 5 OPERABLE UNIT: 1
DOCUMENT NUMBER: 3.1-OU1-17 TYPE: LETTER T.O. ACTION:
AUTHOR: DAVID E. MOHR, P.E. PROJECT COORDINATOR
AUTHOR'S ORG: URS

ADDRESSEE: BRYAN HAELSIG
ADDRESSEE'S ORG: EFA, NW

ID #: 228

SUB-HEAD: 03.1 CORRESPONDENCE
TITLE: RESPONSE TO REGULATORY AGENCY REVIEW COMMENTS (RE: NOV 1990
AIR PATHWAY ANALYSIS WORK PLAN)

DATE: # OF PAGES: 8 OPERABLE UNIT: 1
DOCUMENT NUMBER: 3.1-OU1-18 TYPE: COMMENTS T.O. ACTION:
AUTHOR:
AUTHOR'S ORG:

ADDRESSEE:
ADDRESSEE'S ORG:

ID #: 268

SUB-HEAD: 03.1 CORRESPONDENCE
TITLE: CONFIRMATION OF PHONE CONVERSATION 11/16/90 RE: AN
ADDITIONAL HYDROGEOLOGICAL ISSUE

DATE: 11/16/90 # OF PAGES: 1 OPERABLE UNIT: 1
DOCUMENT NUMBER: 3.1-OU1-19 TYPE: LETTER T.O. ACTION:
AUTHOR: NANCY HARNEY
AUTHOR'S ORG: ENVIRONMENTAL PROTECTION AGENCY

ADDRESSEE: BRYAN HAELSIG
ADDRESSEE'S ORG: EFA, NW

ID #: 288

SUB-HEAD: 03.1 CORRESPONDENCE
TITLE: AREAS 5 & 6 DRAFT RI/FS PROJECT PLAN COMMENTS

DATE: # OF PAGES: 1 OPERABLE UNIT: 1
DOCUMENT NUMBER: 3.1-OU1-2 TYPE: MEMO T.O. ACTION:
AUTHOR: MATT KLOPE
AUTHOR'S ORG: NAS WHIDBEY ISLAND, WASHINGTON

ADDRESSEE:
ADDRESSEE'S ORG:

ID #: 269

3-HEAD: 03.1 CORRESPONDENCE

TITLE: REVIEW OF REQUEST FOR CONDITIONAL APPROVAL OF THE DRAFT
FINAL MANAGEMENT PLANS FOR O.U. A

DATE: 11/16/90 # OF PAGES: 3 OPERABLE UNIT: 1
DOCUMENT NUMBER: 3.1-OU1-20 TYPE: LETTER T.O. ACTION:
AUTHOR: BARRY ROGOWSKI
AUTHOR'S ORG: ENVIRONMENTAL PROTECTION AGENCY

ADDRESSEE: BRYAN HAELSIG
ADDRESSEE'S ORG: EFA, NW

ID #: 271

SUB-HEAD: 03.1 CORRESPONDENCE

TITLE: DISCUSSION CONFIRMATION

DATE: 12/5/90 # OF PAGES: 1 OPERABLE UNIT: 1
DOCUMENT NUMBER: 3.1-OU1-21 TYPE: LETTER T.O. ACTION:
AUTHOR: NANCY HARNEY
AUTHOR'S ORG: ENVIRONMENTAL PROTECTION AGENCY

ADDRESSEE: BRYAN HAELSIG
ADDRESSEE'S ORG: EFA, NW

ID #: 270

SUB-HEAD: 03.1 CORRESPONDENCE

TITLE: COMMENTS ON DRAFT FINAL MANAGEMENT PLANS

DATE: 12/14/90 # OF PAGES: 34 OPERABLE UNIT: 1
DOCUMENT NUMBER: 3.1-OU1-22 TYPE: LETTER T.O. ACTION:
AUTHOR: NANCY HARNEY
AUTHOR'S ORG: ENVIRONMENTAL PROTECTION AGENCY

ADDRESSEE: BRYAN HAELSIG
ADDRESSEE'S ORG: EFA, NW

ID #: 264

SUB-HEAD: 03.1 CORRESPONDENCE

TITLE: COMMENTS ON AIR PATHWAYS ANALYSIS WORK PLAN

DATE: 1/3/91 # OF PAGES: 3 OPERABLE UNIT: 1
DOCUMENT NUMBER: 3.1-OU1-23 TYPE: LETTER T.O. ACTION:
AUTHOR: BARRY ROGOWSKI
AUTHOR'S ORG: WASHINGTON STATE DEPARTMENT OF ECOLOGY

ADDRESSEE: BRYAN HAELSIG
ADDRESSEE'S ORG: EFA, NW

ENGINEERING FIELD ACTIVITY, NW
NAS WHIDBEY
ADMINISTRATIVE RECORD INDEX

ID #: 263

SUB-HEAD: 03.1 CORRESPONDENCE

TITLE: TO CONFIRM PHONE CON ABOUT CHANGES IN REVIEW SCHEDULES

DATE: 1/3/91 # OF PAGES: 1

OPERABLE UNIT: 1

DOCUMENT NUMBER: 3.1-OU1-24 TYPE: LETTER

T.O. ACTION:

AUTHOR: NANCY HARNEY

AUTHOR'S ORG: ENVIRONMENTAL PROTECTION AGENCY

ADDRESSEE: BRYAN HAELSIG

ADDRESSEE'S ORG: EFA, NW

ID #: 265

SUB-HEAD: 03.1 CORRESPONDENCE

TITLE: COMMENTS ON AIR PATHWAYS ANALYSIS WORK PLAN

DATE: 1/9/91 # OF PAGES: 8

OPERABLE UNIT: 1

DOCUMENT NUMBER: 3.1-OU1-25 TYPE: LETTER

T.O. ACTION:

AUTHOR: NANCY HARNEY

AUTHOR'S ORG: ENVIRONMENTAL PROTECTION AGENCY

ADDRESSEE: BRYAN HAELSIG

ADDRESSEE'S ORG: EFA, NW

ID #: 259

SUB-HEAD: 03.1 CORRESPONDENCE

TITLE: BACKGROUND SURFACE WATER SAMPLING (WETLAND) SAMPLING FOR
AREA 5, NAS WHIDBEY ISLAND, WASHINGTON

DATE: 1/15/91 # OF PAGES:

OPERABLE UNIT: 1

DOCUMENT NUMBER: 3.1-OU1-26 TYPE: LETTER

T.O. ACTION:

AUTHOR: BARRY ROGOWSKI

AUTHOR'S ORG: WASHINGTON STATE DEPARTMENT OF ECOLOGY

ADDRESSEE: BRYAN HAELSIG

ADDRESSEE'S ORG: EFA, NW

ID #: 260

SUB-HEAD: 03.1 CORRESPONDENCE

TITLE: BRUCE WOODS COMMENTS PERTAINING TO QA REVIEW OF SAIC'S
STANDARD OPER PROC

DATE: 1/18/91 # OF PAGES: 2

OPERABLE UNIT: 1

DOCUMENT NUMBER: 3.1-OU1-27 TYPE: LETTER

T.O. ACTION:

AUTHOR: NANCY HARNEY

AUTHOR'S ORG: ENVIRONMENTAL PROTECTION AGENCY

ADDRESSEE: BRYAN HAELSIG

ADDRESSEE'S ORG: EFA, NW

ID #: 272

SUB-HEAD: 03.1 CORRESPONDENCE

TITLE: COMMENTS ON INTERIM ACTION DRAFT TECHNICAL MEMO, OPERABLE UNIT 1

DATE: 2/12/91 # OF PAGES: 1 OPERABLE UNIT: 1
DOCUMENT NUMBER: 3.1-OU1-28 TYPE: LETTER & ENCLOSUR T.O. ACTION:
AUTHOR: KATHY SOUDERS
AUTHOR'S ORG: NAVAL AIR STATION WHIDBEY ISLAND, WASHINGTON

ADDRESSEE: COMMANDING OFFICER
ADDRESSEE'S ORG: EFA, NW

ID #: 107

SUB-HEAD: 03.1 CORRESPONDENCE

TITLE: COMMENTS ON REVISED DRAFT TECHNICAL MEMORANDUM FOR AREAS 5 & 6 INTERIM ACTION AT NAS WHIDBEY

DATE: 2/13/91 # OF PAGES: 9 OPERABLE UNIT: 1
DOCUMENT NUMBER: 3.1-OU1-29 TYPE: LETTER & ENCLOSUR T.O. ACTION:
AUTHOR: NANCY HARNEY
AUTHOR'S ORG: ENVIRONMENTAL PROTECTION AGENCY

ADDRESSEE: BRYAN HAELSIG
ADDRESSEE'S ORG: EFA, NW

ID #: 279

SUB-HEAD: 03.1 CORRESPONDENCE

TITLE: COMMENTS ON AREAS 5 & 6 INTERIM ACTION WHIDBEY ISLAND AS OF MARCH 02, 1990

DATE: 4/5/90 # OF PAGES: 2 OPERABLE UNIT: 1
DOCUMENT NUMBER: 3.1-OU1-3 TYPE: LETTER T.O. ACTION:
AUTHOR: ROBERT A. POSS
AUTHOR'S ORG: DEPARTMENT OF ECOLOGY

ADDRESSEE: PATRICK R. VASICEK
ADDRESSEE'S ORG: EFA, NW

ID #: 273

SUB-HEAD: 03.1 CORRESPONDENCE

TITLE: COMMENTS ON NAS WHIDBEY ISLAND, FINAL RI/FS WORKPLAN

DATE: 2/26/91 # OF PAGES: 8 OPERABLE UNIT: 1
DOCUMENT NUMBER: 3.1-OU1-30 TYPE: LETTER T.O. ACTION:
AUTHOR: NANCY HARNEY
AUTHOR'S ORG: ENVIRONMENTAL PROTECTION AGENCY

ADDRESSEE: BRYAN HAELSIG
ADDRESSEE'S ORG: EFA, NW

SUB-HEAD: 03.1 CORRESPONDENCE
TITLE: GRANTING OF WELL CONSTRUCTION VARIANCE

ID #: 278

DATE: 3/8/91 # OF PAGES: 2
DOCUMENT NUMBER: 3.1-OU1-31 TYPE: LETTER
AUTHOR: HERMAN H. HUGGINS
AUTHOR'S ORG: DEPARTMENT OF ECOLOGY

OPERABLE UNIT: 1
T.O. ACTION:

ADDRESSEE: KEVIN STIGILE
ADDRESSEE'S ORG: EFA, NW

SUB-HEAD: 03.1 CORRESPONDENCE
TITLE: COMMENTS ON DRAFT FINAL AIR PATHWAYS WORKPLAN, OPERABLE
UNIT 1

ID #: 277

DATE: 3/18/91 # OF PAGES: 3
DOCUMENT NUMBER: 3.1-OU1-32 TYPE: LETTER
AUTHOR: BARRY ROGOWSKY
AUTHOR'S ORG: DEPARTMENT OF ECOLOGY

OPERABLE UNIT: 1
T.O. ACTION:

ADDRESSEE: BRYAN HAELSIG
ADDRESSEE'S ORG: EFA, NW

SUB-HEAD: 03.1 CORRESPONDENCE
TITLE: NOTIFICATION OF LABORATORY APPROVAL

ID #: 275

DATE: 3/18/91 # OF PAGES: 1
DOCUMENT NUMBER: 3.1-OU1-33 TYPE: LETTER
AUTHOR: THOMAS FLOR
AUTHOR'S ORG: NEESA

OPERABLE UNIT: 1
T.O. ACTION:

ADDRESSEE: COMMANDING OFFICER (CODE 09ER)
ADDRESSEE'S ORG: EFA, NW

SUB-HEAD: 03.1 CORRESPONDENCE
TITLE: DISCUSSION OF NAVY'S RESPONSE TO COMMENTS ON DRAFT AIR
PATHWAYS ANALYSIS WORKPLAN

ID #: 276

DATE: 3/20/91 # OF PAGES: 2
DOCUMENT NUMBER: 3.1-OU1-34 TYPE: LETTER
AUTHOR: NANCY HARNEY
AUTHOR'S ORG: ENVIRONMENTAL PROTECTION AGENCY

OPERABLE UNIT: 1
T.O. ACTION:

ADDRESSEE: BRYAN HAELSIG
ADDRESSEE'S ORG: EFA, NW

ID #: 241

SUB-HEAD: 03.1 CORRESPONDENCE
TITLE: NOTIFICATION OF ADDITIONAL LABORATORY SITE APPROVAL

DATE: 5/6/91 # OF PAGES: 1 OPERABLE UNIT: 1
DOCUMENT NUMBER: 3.1-OU1-35 TYPE: LETTER T.O. ACTION:
AUTHOR: THOMAS H. FLOR
AUTHOR'S ORG: DEPT OF THE NAVY NAVY ENERGY AND ENVIRONMENTAL PT HUENEME,
CA
ADDRESSEE: COMMANDING OFFICER, EFA NW (09ER)
ADDRESSEE'S ORG: EFA, NW

ID #: 823

SUB-HEAD: 03.1 CORRESPONDENCE
TITLE: FINAL REVISION OF THE AIR PATHWAY ANALYSIS PLANS

DATE: 9/9/91 # OF PAGES: 1 OPERABLE UNIT: 1
DOCUMENT NUMBER: 3.1-OU1-36 TYPE: LETTER T.O. ACTION:
AUTHOR: PAUL MARCHANT
AUTHOR'S ORG: WASHINGTON DEPT OF ECOLOGY

ADDRESSEE: BRYAN HAELSIG
ADDRESSEE'S ORG: EFA, NW

ID #: 824

SUB-HEAD: 03.1 CORRESPONDENCE
TITLE: PROPOSED MODIFICATION TO FEDERAL FACILITIES AGREEMENT
DELIVERABLE SCHEDULE

DATE: 11/6/91 # OF PAGES: 1 OPERABLE UNIT: 1
DOCUMENT NUMBER: 3.1-OU1-37 TYPE: LETTER T.O. ACTION:
AUTHOR: PAUL MARCHANT
AUTHOR'S ORG: WASHINGTON STATE DEPT OF ECOLOGY

ADDRESSEE: BRYAN HAELSIG
ADDRESSEE'S ORG: EFA, NW

ID #: 825

SUB-HEAD: 03.1 CORRESPONDENCE
TITLE: COMMENTS LETTER DATED OCT 24, 91 CONCERNING INTERIM ACTION

DATE: 11/6/91 # OF PAGES: 2 OPERABLE UNIT: 1
DOCUMENT NUMBER: 3.1-OU1-38 TYPE: LETTER T.O. ACTION:
AUTHOR: NANCY HARNEY
AUTHOR'S ORG: ENVIRONMENTAL PROTECTION AGENCY

ADDRESSEE: KEVIN STIGILE
ADDRESSEE'S ORG: EFA, NW

ID #: 1510

SUB-HEAD: 03.1 CORRESPONDENCE
TITLE: EXTENSION OF 30 DAY COMMENT PERIOD

DATE: 3/31/92 # OF PAGES: 1 OPERABLE UNIT: 1
DOCUMENT NUMBER: 3.1-OU1-39 TYPE: LETTER T.O. ACTION:
AUTHOR: PAUL MARCHANT
AUTHOR'S ORG: STATE OF WASHINGTON DEPARTMENT OF ECOLOGY

ADDRESSEE: BRYAN HAELSIG
ADDRESSEE'S ORG: EFA, NW

ID #: 280

SUB-HEAD: 03.1 CORRESPONDENCE
TITLE: RESPONSE TO EPA COMMENTS ON SCOPE OF WORK FOR RI/FS AT
LANDFILL SITES 5 & 6 NAS WHIDBEY

DATE: 5/01/90 # OF PAGES: 5 OPERABLE UNIT: 1
DOCUMENT NUMBER: 3.1-OU1-4 TYPE: LETTER T.O. ACTION:
AUTHOR: BUB LOISELLE
AUTHOR'S ORG: ENVIRONMENTAL PROTECTION AGENCY

ADDRESSEE: PATRICK R. VASICEK
ADDRESSEE'S ORG: EFA, NW

ID #: 1660

SUB-HEAD: 03.1 CORRESPONDENCE
TITLE: RESULTS OF CONFIRMATORY SAMPLING

DATE: 7/30/92 # OF PAGES: 3 OPERABLE UNIT: 1
DOCUMENT NUMBER: 3.1-OU1-40 TYPE: LETTER T.O. ACTION:
AUTHOR:
AUTHOR'S ORG: URS

ADDRESSEE: BRYAN HAELSIG
ADDRESSEE'S ORG: EFA, NW

ID #: 1661

SUB-HEAD: 03.1 CORRESPONDENCE
TITLE: COMMENTS ON DRAFT FINAL REMEDIAL INVESTIGATION

DATE: 8/3/92 # OF PAGES: 2 OPERABLE UNIT: 1
DOCUMENT NUMBER: 3.1-OU1-41 TYPE: LETTER T.O. ACTION:
AUTHOR: PAUL MARCHANT
AUTHOR'S ORG: WASHINGTON STATE DEPT OF ECOLOGY

ADDRESSEE: BRYAN HAELSIG
ADDRESSEE'S ORG: EFA, NW

ID #: 2946

SUB-HEAD: 03.1 CORRESPONDENCE
TITLE: SUBMITTAL OF DRAFT FIELD SAMPLING AND QUALITY ASSURANCE
PROJECT PLAN ADDENDA FOR ADDITIONAL SAMPLING AT OUI

DATE: 11/17/92 # OF PAGES: 1 OPERABLE UNIT: 1
DOCUMENT NUMBER: 3.1-OUI-42 TYPE: LETTER T.O. ACTION:
AUTHOR: KEVIN W. STIGILE
AUTHOR'S ORG: EFA, NW

ADDRESSEE: NANCY HARNEY/PAUL MARCHANT
ADDRESSEE'S ORG: EPA/WASHINGTON STATE DEPARTMENT OF ECOLOGY

ID #: 3340

SUB-HEAD: 03.1 CORRESPONDENCE
TITLE: SENDING THE WELL 6-D-4 CLOSURE PLAN

DATE: 11/20/92 # OF PAGES: 1 OPERABLE UNIT: 1
DOCUMENT NUMBER: 3.1-OUI-43 TYPE: LETTER T.O. ACTION:
AUTHOR: KEVIN STIGILE
AUTHOR'S ORG: EFA, NW

ADDRESSEE: NANCY HARNEY/PAUL MARCHANT
ADDRESSEE'S ORG: EPA/WASHINGTON STATE DEPT OF ECOLOGY

ID #: 2947

SUB-HEAD: 03.1 CORRESPONDENCE
TITLE: ANNOUNCING THAT KARL POHLMANN WILL BE ON-SITE 12/30 TO 1/7
TO SAMPLE 6 GROUND WATER MONITORING WELLS

DATE: 12/9/92 # OF PAGES: 2 OPERABLE UNIT: 1
DOCUMENT NUMBER: 3.1-OUI-44 TYPE: LETTER T.O. ACTION:
AUTHOR: NADINE L. ROMERO
AUTHOR'S ORG: WASHINGTON STATE DEPT OF ECOLOGY

ADDRESSEE: BRYAN HAELSIG
ADDRESSEE'S ORG: EFA, NW

ID #: 3341

SUB-HEAD: 03.1 CORRESPONDENCE
TITLE: SENDING THE MINUTES FOR NOV, 25, '92 MEETING

DATE: 12/14/92 # OF PAGES: 5 OPERABLE UNIT: 1
DOCUMENT NUMBER: 3.1-OUI-45 TYPE: LETTER T.O. ACTION:
AUTHOR: KEVIN STIGILE
AUTHOR'S ORG: EFA, NW

ADDRESSEE: NANCY HARNEY/PAUL MARCHANT
ADDRESSEE'S ORG: EPA/WASHINGTON STATE DEPT OF ECOLOGY

ID #: 2948

SUB-HEAD: 03.1 CORRESPONDENCE
TITLE: MEETING MINUTES OF NOV 25, 92 CONFERENCE CALL

DATE: 12/16/92 # OF PAGES: 7 OPERABLE UNIT: 1
DOCUMENT NUMBER: 3.1-OU1-45 TYPE: LETTER T.O. ACTION:
AUTHOR: KEVIN STIGILE
AUTHOR'S ORG: EFA, NW

ADDRESSEE: NANCY HARNEY/PAUL MARCHANT
ADDRESSEE'S ORG: EPA/WASHINGTON STATE DEPT OF ECOLOGY

ID #: 2949

SUB-HEAD: 03.1 CORRESPONDENCE
TITLE: ABANDONMENT OF WELL 6-D-4

DATE: 12/15/92 # OF PAGES: 1 OPERABLE UNIT: 1
DOCUMENT NUMBER: 3.1-OU1-47 TYPE: LETTER T.O. ACTION:
AUTHOR: PAUL MARCHANT
AUTHOR'S ORG: WASHINGTON STATE DEPARTMENT OF ECOLOGY

ADDRESSEE: BRYAN HAELSIG
ADDRESSEE'S ORG: EFA, NW

ID #: 2950

SUB-HEAD: 03.1 CORRESPONDENCE
TITLE: FOLLOW-UP LETTER OF ECOLOGIES REGARDING AGREEMENTS REACHED
ON THE ABANDONMENT OF WELL 6-D-4

DATE: 12/23/92 # OF PAGES: 1 OPERABLE UNIT: 1
DOCUMENT NUMBER: 3.1-OU1-48 TYPE: LETTER T.O. ACTION:
AUTHOR: NANCY HARNEY
AUTHOR'S ORG: EPA

ADDRESSEE: BRYAN HAELSIG
ADDRESSEE'S ORG: EFA, NW

ID #: 2951

SUB-HEAD: 03.1 CORRESPONDENCE
TITLE: SUBMITTAL OF FINAL FIELD SAMPLING AND QUALITY ASSURANCE
PROJECT PLAN ADDENDA FOR ADDITIONAL SAMPLING AT OU 1

DATE: 1/20/93 # OF PAGES: 1 OPERABLE UNIT: 1
DOCUMENT NUMBER: 3.1-OU1-49 TYPE: LETTER T.O. ACTION:
AUTHOR: KEVIN W. STIGILE
AUTHOR'S ORG: EFA, NW

ADDRESSEE: COMMANDING OFFICER
ADDRESSEE'S ORG: NAVAL AIR STATION WHIDBEY ISLAND

ID #: 281

SUB-HEAD: 03.1 CORRESPONDENCE
TITLE: FOLLOW-UP TO THE RI/FS MID-COURSE CORRECTION MEETING HELD
5/11/90

DATE: 5/17/90 # OF PAGES: 2 OPERABLE UNIT: 1
DOCUMENT NUMBER: 3.1-OU1-5 TYPE: LETTER T.O. ACTION:
AUTHOR: BUB LOISELLE
AUTHOR'S ORG: ENVIRONMENTAL PROTECTION AGENCY

ADDRESSEE: BRYAN HAELSIG
ADDRESSEE'S ORG: EFA, NW

ID #: 2952

SUB-HEAD: 03.1 CORRESPONDENCE
TITLE: SUBMITTAL OF FINAL FIELD SAMPLING AND QUALITY ASSURANCE
PROJECT PLAN ADDENDA FOR ADDITIONAL SAMPLING AT OU 1

DATE: 1/20/93 # OF PAGES: 1 OPERABLE UNIT: 1
DOCUMENT NUMBER: 3.1-OU1-50 TYPE: LETTER T.O. ACTION:
AUTHOR: KEVIN STIGILE
AUTHOR'S ORG: EFA, NW

ADDRESSEE: NANCY HARNEY/PAUL MARCHANT
ADDRESSEE'S ORG: EPA/WASHINGTON STATE DEPT OF ECOLOGY

ID #: 2953

SUB-HEAD: 03.1 CORRESPONDENCE
TITLE: CLOSURE REPORT FOR WELL 6-D AT NAVAL AIR STATION WHIDBEY
ISLAND

DATE: 3/1/93 # OF PAGES: 1 OPERABLE UNIT: 1
DOCUMENT NUMBER: 3.1-OU1-51 TYPE: LETTER T.O. ACTION:
AUTHOR: BELA J. VARGA
AUTHOR'S ORG: EFA, NW

ADDRESSEE: COMMANDING OFFICER
ADDRESSEE'S ORG: NAVAL AIR STATION WHIDBEY ISLAND

ID #: 2955

SUB-HEAD: 03.1 CORRESPONDENCE
TITLE: SELECTION OF BACKGROUND LOCATIONS FOR GROUNDWATER AND SOILS

DATE: 3/23/93 # OF PAGES: 4 OPERABLE UNIT: 1
DOCUMENT NUMBER: 3.1-OU1-52 TYPE: LETTER T.O. ACTION:
AUTHOR: VIVIANNE C. LARKIN
AUTHOR'S ORG: URS

ADDRESSEE: BRYAN HAELSIG
ADDRESSEE'S ORG: EFA, NW

ID #: 2956

SUB-HEAD: 03.1 CORRESPONDENCE

TITLE: SENDING REPORT ADDRESSING THE SAMPLING ACTIVITIES, SUMMARY OF THE ANALYTICAL RESULTS FOR EACH SAMPLE, ANALYTICAL DATA, CHAIN OF CUSTODY

DATE: 3/24/93 # OF PAGES: 1 OPERABLE UNIT: 1

DOCUMENT NUMBER: 3.1-OU1-53 TYPE: LETTER T.O. ACTION:

AUTHOR: STEVE HULSMAN

AUTHOR'S ORG: WASHINGTON STATE DEPARTMENT OF ECOLOGY

ADDRESSEE: BRYAN HAELSIG

ADDRESSEE'S ORG: EFA, NW

ID #: 3342

SUB-HEAD: 03.1 CORRESPONDENCE

TITLE: SENDING RESPONSE TO COMMENTS ON THE DRAFT FEASIBILITY STUDY

DATE: 4/2/93 # OF PAGES: 1 OPERABLE UNIT: 1

DOCUMENT NUMBER: 3.1-OU1-55 TYPE: LETTER T.O. ACTION:

AUTHOR: BELA VARGA

AUTHOR'S ORG: EFA, NW

ADDRESSEE: NANCY HARNEY/PAUL MARCHANT

ADDRESSEE'S ORG: EPA/WASHINGTON STATE DEPT OF ECOLOGY

ID #: 3343

SUB-HEAD: 03.1 CORRESPONDENCE

TITLE: LETTER OF SUBMITTAL OF REVISED DRAFT FINAL REMEDIAL INVESTIGATION

DATE: 4/22/93 # OF PAGES: 1 OPERABLE UNIT: 1

DOCUMENT NUMBER: 3.1-OU1-56 TYPE: LETTER T.O. ACTION:

AUTHOR: BELA VARGA

AUTHOR'S ORG: EFA, NW

ADDRESSEE: NANCY HARNEY/PAUL MARCHANT

ADDRESSEE'S ORG: EPA/WASHINGTON STATE DEPT OF ECOLOGY

ID #: 3344

SUB-HEAD: 03.1 CORRESPONDENCE

TITLE: SENDING SUBMITTAL OF REVISED DRAFT FINAL REMEDIAL INVESTIGATION

DATE: 4/22/93 # OF PAGES: 1 OPERABLE UNIT: 1

DOCUMENT NUMBER: 3.1-OU1-57 TYPE: LETTER T.O. ACTION:

AUTHOR: BELA VARGA

AUTHOR'S ORG: EFA, NW

ADDRESSEE: COMMANDING OFFICER

ADDRESSEE'S ORG: NAS WHIDBEY

ID #: 3346

SUB-HEAD: 03.1 CORRESPONDENCE

TITLE: SENDING SUBMITTAL OF DRAFT FINAL FEASIBILITY STUDY AND
DRAFT PROPOSED PLAN

DATE: 5/6/93 # OF PAGES: 1 OPERABLE UNIT: 1
DOCUMENT NUMBER: 3.1-OU1-59 TYPE: LETTER T.O. ACTION:
AUTHOR: BELA VARGA
AUTHOR'S ORG: EFA, NW

ADDRESSEE: COMMANDING OFFICER
ADDRESSEE'S ORG: NAS WHIDBEY

ID #: 300

SUB-HEAD: 03.1 CORRESPONDENCE

TITLE: COMMENTS ON SCOPE OF WORK FOR RI/FS LANDFILL SITES 5 & 6
NAS WHIDBEY

DATE: 5/02/90 # OF PAGES: 1 OPERABLE UNIT: 1
DOCUMENT NUMBER: 3.1-OU1-6 TYPE: LETTER T.O. ACTION:
AUTHOR: ROBERT A. POSS
AUTHOR'S ORG: DEPARTMENT OF ECOLOGY

ADDRESSEE: BUB LOISELLE
ADDRESSEE'S ORG: EFA, NW

ID #: 3347

SUB-HEAD: 03.1 CORRESPONDENCE

TITLE: SUBMITTAL OF FINAL REMEDIAL INVESTIGATION AND FEASIBILITY
STUDIES

DATE: 6/17/93 # OF PAGES: 1 OPERABLE UNIT: 1
DOCUMENT NUMBER: 3.1-OU1-60 TYPE: LETTER T.O. ACTION:
AUTHOR: BELA VARGA
AUTHOR'S ORG: EFA, NW

ADDRESSEE: NANCY HARNEY/PAUL MARCHANT
ADDRESSEE'S ORG: EPA/WASHINGTON STATE DEPT OF ECOLOGY

ID #: 3348

SUB-HEAD: 03.1 CORRESPONDENCE

TITLE: SUBMITTAL OF FINAL REMEDIAL INVESTIGATION AND FEASIBILITY
STUDIES

DATE: 6/17/93 # OF PAGES: 1 OPERABLE UNIT: 1
DOCUMENT NUMBER: 3.1-OU1-61 TYPE: LETTER T.O. ACTION:
AUTHOR: BELA VARGA
AUTHOR'S ORG: EFA, NW

ADDRESSEE: COMMANDING OFFICER
ADDRESSEE'S ORG: NAS WHIDBEY

ENGINEERING FIELD ACTIVITY, NW
NAS WHIDBEY
ADMINISTRATIVE RECORD INDEX

ID #: 282

3-HEAD: 03.1 CORRESPONDENCE
TITLE: LIST OF ACTION ITEMS

DATE: 5/30/90 # OF PAGES: 12 OPERABLE UNIT: 1
DOCUMENT NUMBER: 3.1-OU1-7 TYPE: LETTER T.O. ACTION:
AUTHOR: BUB LOISELLE
AUTHOR'S ORG: ENVIRONMENTAL PROTECTION AGENCY

ADDRESSEE: BRYAN HAELSIG
ADDRESSEE'S ORG: EFA, NW

ID #: 283

SUB-HEAD: 03.1 CORRESPONDENCE
TITLE: REVIEW COMMENTS ON DRAFT FINAL INTERIM ACTION PROJECT PLANS

DATE: 6/05/90 # OF PAGES: 16 OPERABLE UNIT: 1
DOCUMENT NUMBER: 3.1-OU1-8 TYPE: LETTER T.O. ACTION:
AUTHOR: KATHRYN A. SOUDERS
AUTHOR'S ORG: NAS WHIDBEY

ADDRESSEE: COMMANDING OFFICER
ADDRESSEE'S ORG: EFA, NW

ID #: 284

SUB-HEAD: 03.1 CORRESPONDENCE
TITLE: ECOLOGY'S COMMENTS ON DRAFT FINAL INTERIM ACTION PROJECT
PLANS FOR OU A (AREAS 5 & 6)

DATE: 6/05/90 # OF PAGES: 3 OPERABLE UNIT: 1
DOCUMENT NUMBER: 3.1-OU1-9 TYPE: LETTER T.O. ACTION:
AUTHOR: ROBERT A. POSS
AUTHOR'S ORG: DEPARTMENT OF ECOLOGY

ADDRESSEE: PATRICK R. VASICEK
ADDRESSEE'S ORG: EFA, NW

ID #: 840

SUB-HEAD: 03.10 COMMENTS
TITLE: SCOPE OF WORK FOR RI/FS LANDFILL

DATE: 5/2/90 # OF PAGES: 1 OPERABLE UNIT: 1
DOCUMENT NUMBER: 3.10-OU1-1 TYPE: LETTER T.O. ACTION:
AUTHOR: ROBERT A. POSS
AUTHOR'S ORG: WASHINGTON STATE DEPARTMENT OF ECOLOGY

ADDRESSEE: BUB LOISELLE
ADDRESSEE'S ORG: ENVIRONMENTAL PROTECTION AGENCY

ID #: 1665

3-HEAD: 03.10 COMMENTS
TITLE: COMMENTS ON DRAFT FEASIBILITY STUDY

DATE: 7/21/92 # OF PAGES: 5 OPERABLE UNIT: 1
DOCUMENT NUMBER: 3.10-OU1-10 TYPE: LETTER T.O. ACTION:
AUTHOR: KATHY SOUDERS
AUTHOR'S ORG: ROICC WHIDBEY

ADDRESSEE: BRYAN HAELSIG
ADDRESSEE'S ORG: EFA, NW

ID #: 1666

SUB-HEAD: 03.10 COMMENTS
TITLE: COMMENTS ON DRAFT FEASIBILITY STUDY FOR OU1

DATE: 7/24/92 # OF PAGES: 13 OPERABLE UNIT: 1
DOCUMENT NUMBER: 3.10-OU1-11 TYPE: LETTER T.O. ACTION:
AUTHOR: PAUL MARCHANT
AUTHOR'S ORG: WASHINGTON STATE DEPARTMENT OF ECOLOGY

ADDRESSEE: BRYAN HAELSIG
ADDRESSEE'S ORG: EFA, NW

ID #: 1667

SUB-HEAD: 03.10 COMMENTS
TITLE: COMMENTS ON DRAFT FINAL REMEDIAL INVESTIGATION FOR OU 1

DATE: 7/28/92 # OF PAGES: 15 OPERABLE UNIT: 1
DOCUMENT NUMBER: 3.10-OU1-12 TYPE: LETTER T.O. ACTION:
AUTHOR: NANCY HARNEY
AUTHOR'S ORG: ENVIRONMENTAL PROTECTION AGENCY

ADDRESSEE: BRYAN HAELSIG
ADDRESSEE'S ORG: EFA, NW

ID #: 1668

SUB-HEAD: 03.10 COMMENTS
TITLE: REMAINING COMMENTS OF EPA'S COMMENTS ON THE DRAFT FINAL RI
REPORT

DATE: 8/4/92 # OF PAGES: 13 OPERABLE UNIT: 1
DOCUMENT NUMBER: 3.10-OU1-13 TYPE: LETTER T.O. ACTION:
AUTHOR: NANCY HARNEY
AUTHOR'S ORG: ENVIRONMENTAL PROTECTION AGENCY

ADDRESSEE: BRYAN HAELSIG
ADDRESSEE'S ORG: EFA, NW

ID #: 1966

3-HEAD: 03.10 COMMENTS

TITLE: COMMENTS ON DRAFT FINAL REMEDIAL INVESTIGATION REPORT

DATE: 8/18/92

OF PAGES: 27

OPERABLE UNIT: 1

DOCUMENT NUMBER: 3.10-OU1-14 TYPE: LETTER

T.O. ACTION:

AUTHOR: PAUL MARCHANT

AUTHOR'S ORG: STATE OF WASHINGTON DEPARTMENT OF ECOLOGY

ADDRESSEE: BRYAN HAELSIG

ADDRESSEE'S ORG: EFA, NW

ID #: 2979

SUB-HEAD: 03.10 COMMENTS

TITLE: ECOLOGY COMMENTS IF THE WELL CLOSURE PLAN FOR WELL 6-D-4

DATE: 12/9/92

OF PAGES: 1

OPERABLE UNIT: 1

DOCUMENT NUMBER: 3.10-OU1-15 TYPE: LETTER

T.O. ACTION:

AUTHOR: PAUL MARCHANT

AUTHOR'S ORG: WASHINGTON STATE DEPARTMENT OF ECOLOGY

ADDRESSEE: BRYAN HAELSIG

ADDRESSEE'S ORG: EFA, NW

ID #: 3286

SUB-HEAD: 03.10 COMMENTS

TITLE: COMMENTS OF THE DRAFT FINAL REMEDIAL INVESTIGATION REPORT

DATE: 5/27/93

OF PAGES: 24

OPERABLE UNIT: 1

DOCUMENT NUMBER: 3.10-OU1-16 TYPE: LETTER

T.O. ACTION:

AUTHOR: NANCY HARNEY

AUTHOR'S ORG: EPA

ADDRESSEE: BRYAN HAELSIG

ADDRESSEE'S ORG: EFA, NW

ID #: 3287

SUB-HEAD: 03.10 COMMENTS

TITLE: COMMENTS ON THE DRAFT FINAL FEASIBILITY STUDY

DATE: 6/1/93

OF PAGES: 2

OPERABLE UNIT: 1

DOCUMENT NUMBER: 3.10-OU1-17 TYPE: LETTER

T.O. ACTION:

AUTHOR: K. J. SKINNER

AUTHOR'S ORG: NAS WHIDBEY

ADDRESSEE: COMMANDING OFFICER

ADDRESSEE'S ORG: EFA, NW

ID #: 3288

SUB-HEAD: 03.10 COMMENTS
TITLE: COMMENTS ON THE REVISED DRAFT FINAL FEASIBILITY STUDY REPORT

DATE: 6/1/93 # OF PAGES: 14 OPERABLE UNIT: 1
DOCUMENT NUMBER: 3.10-OU1-18 TYPE: LETTER T.O. ACTION:
AUTHOR: PAUL MARCHANT
AUTHOR'S ORG: WASHINGTON STATE DEPT OF ECOLOGY

ADDRESSEE: BRYAN HAELSIG
ADDRESSEE'S ORG: EFA, NW

ID #: 3289

SUB-HEAD: 03.10 COMMENTS
TITLE: COMMENTS ON REVISED DRAFT FINAL REMEDIAL INVESTIGATION REPORT

DATE: 6/1/93 # OF PAGES: 6 OPERABLE UNIT: 1
DOCUMENT NUMBER: 3.10-OU1-19 TYPE: LETTER T.O. ACTION:
AUTHOR: PAUL MARCHANT
AUTHOR'S ORG: WASHINGTON STATE DEPT OF ECOLOGY

ADDRESSEE: BRYAN HAELSIG
ADDRESSEE'S ORG: EFA, NW

ID #: 564

SUB-HEAD: 03.10 COMMENTS
TITLE: COMMENTS ON DRAFT MANAGEMENT PLANS FOR OPERABLE UNIT 1

DATE: 10/2/90 # OF PAGES: 2 OPERABLE UNIT: 1
DOCUMENT NUMBER: 3.10-OU1-2 TYPE: LETTER T.O. ACTION:
AUTHOR: BARRY ROGOWSKI
AUTHOR'S ORG: DEPARTMENT OF ECOLOGY STATE OF WASHINGTON

ADDRESSEE: BRYAN HAELSIG
ADDRESSEE'S ORG: EFA, NW

ID #: 3291

SUB-HEAD: 03.10 COMMENTS
TITLE: COMMENTS ON THE DRAFT FINAL FEASIBILITY STUDY REPORT

DATE: 6/10/93 # OF PAGES: 13 OPERABLE UNIT: 1
DOCUMENT NUMBER: 3.10-OU1-20 TYPE: LETTER T.O. ACTION:
AUTHOR: NANCY HARNEY
AUTHOR'S ORG: EPA

ADDRESSEE: BRYAN HAELSIG
ADDRESSEE'S ORG: EFA, NW

ID #: 3290

SUB-HEAD: 03.10 COMMENTS

TITLE: COMMENTS OF THE REVISED DRAFT FINAL REMEDIAL INVESTIGATION REPORT

DATE: 6/2/93 # OF PAGES: 2 OPERABLE UNIT: 1
DOCUMENT NUMBER: 3.10-OU1-20 TYPE: LETTER T.O. ACTION:
AUTHOR: K.J. SKINNER
AUTHOR'S ORG: NAS WHIDBEY

ADDRESSEE: COMMANDING OFFICER (09ER)
ADDRESSEE'S ORG: EFA, NW

ID #: 1158

SUB-HEAD: 03.10 COMMENTS

TITLE: RESPONSES TO REGULATORY AGENCY REVIEW COMMENTS OF NOVEMBER 1990 AIR PATHWAY ANALYSIS WORK PLAN

DATE: 1/91 # OF PAGES: 8 OPERABLE UNIT: 1
DOCUMENT NUMBER: 3.10-OU1-3 TYPE: RESPONSES T.O. ACTION:
AUTHOR: URS
AUTHOR'S ORG:

ADDRESSEE:
ADDRESSEE'S ORG:

ID #: 1159

SUB-HEAD: 03.10 COMMENTS

TITLE: RESPONSES TO REGULATORY AGENCY REVIEW COMMENTS RE: JUNE 1991 AIR PATHWAY ANALYSIS WORK PLAN APPENENDICES

DATE: 6/91 # OF PAGES: 9 OPERABLE UNIT: 1
DOCUMENT NUMBER: 3.10-OU1-4 TYPE: RESPONSES T.O. ACTION:
AUTHOR: URS
AUTHOR'S ORG:

ADDRESSEE:
ADDRESSEE'S ORG:

ID #: 1160

SUB-HEAD: 03.10 COMMENTS

TITLE: COMMENTS ON SITE CHARACTERIZATION STUDY REPORT, OPERABLE UNIT 1 NAS WHIDBEY

DATE: 2/20/92 # OF PAGES: 3 OPERABLE UNIT: 1
DOCUMENT NUMBER: 3.10-OU1-5 TYPE: LETTER & COMMENTS T.O. ACTION:
AUTHOR: PAUL MARCHANT
AUTHOR'S ORG: DEPARTMENT OF ECOLOGY STATE OF WASHINGTON

ADDRESSEE: BRYAN HEALSIG
ADDRESSEE'S ORG: EFA, NW

ID #: 1512

SUB-HEAD: 03.10 COMMENTS
TITLE: COMMENTS ON DRAFT REMEDIAL INVESTIGATION REPORT FOR OU 1

DATE: 4/9/92 # OF PAGES: 52 OPERABLE UNIT: 1
DOCUMENT NUMBER: 3.10-OU1-6 TYPE: LETTER T.O. ACTION:
AUTHOR: NANCY HARNEY
AUTHOR'S ORG: ENVIRONMENTAL PROTECTION AGENCY

ADDRESSEE: BRYAN HAELSIG
ADDRESSEE'S ORG: EFA, NW

ID #: 1513

SUB-HEAD: 03.10 COMMENTS
TITLE: COMMENTS ON DRAFT REMEDIAL INVESTIGATION REPORT FOR OU 1

DATE: 4/15/92 # OF PAGES: 16 OPERABLE UNIT: 1
DOCUMENT NUMBER: 3.10-OU1-7 TYPE: LETTER & ENCLOSUR T.O. ACTION:
AUTHOR: PAUL MARCHANT
AUTHOR'S ORG: STATE OF WASHINGTON DEPT OF ECOLOGY

ADDRESSEE: BRYAN HAELSIG
ADDRESSEE'S ORG: EFA, NW

ID #: 1663

SUB-HEAD: 03.10 COMMENTS
TITLE: COMMENTS ON SCOPE OF WORK FOR SAMPLING AND ANALYSIS OF OF
SAMPLES FROM WELL 6-D-4 AND ABANDONMENT OF WELL 6-D-4

DATE: 6/1/92 # OF PAGES: 13 OPERABLE UNIT: 1
DOCUMENT NUMBER: 3.10-OU1-8 TYPE: LETTER T.O. ACTION:
AUTHOR: NANCY HARNEY
AUTHOR'S ORG: ENVIRONMENTAL PROTECTION AGENCY

ADDRESSEE: BRYAN HAELSIG
ADDRESSEE'S ORG: EFA, NW

ID #: 1664

SUB-HEAD: 03.10 COMMENTS
TITLE: COMMENTS ON THE DRAFT FEASIBILITY STUDY REPORT FOR OU1

DATE: 7/21/92 # OF PAGES: 19 OPERABLE UNIT: 1
DOCUMENT NUMBER: 3.10-OU1-9 TYPE: LETTER T.O. ACTION:
AUTHOR: NANCY HARNEY
AUTHOR'S ORG: ENVIRONMENTAL PROTECTION AGENCY

ADDRESSEE: BRYAN HAELSIG
ADDRESSEE'S ORG: EFA, NW

ID #: 2980

SUB-HEAD: 03.10 COMMENTS
TITLE: COMMENTS OF DRAFT FINAL REMEDIAL INVESTIGATION REPORT

DATE: 3/30/93 # OF PAGES: 24 OPERABLE UNIT: 1
DOCUMENT NUMBER: 3.10-OU2-21 TYPE: LETTER T.O. ACTION:
AUTHOR: PATTY MCGRATH
AUTHOR'S ORG: EPA

ADDRESSEE: BRYAN HAELSIG
ADDRESSEE'S ORG: EFA, NW

ID #: 301

SUB-HEAD: 03.2 SCOPES OF WORK
TITLE: COMMENTS ON INTERIM ACTION SAMPLING PLAN FOR AREAS 5 & 6

DATE: 4/19/90 # OF PAGES: 15 OPERABLE UNIT: 1
DOCUMENT NUMBER: 3.2-OU1-1 TYPE: LETTER T.O. ACTION:
AUTHOR: BUB LOISELLE
AUTHOR'S ORG: ENVIRONMENTAL PROTECTION AGENCY

ADDRESSEE: BRYAN HAELSIG
ADDRESSEE'S ORG: EFA, NW

ID #: 2974

SUB-HEAD: 03.2 SCOPES OF WORK
TITLE: FAX'D COPY OF PROJECT QUALITY ASSURANCE AND WORK PLAN

DATE: 12/7/92 # OF PAGES: 11 OPERABLE UNIT: 1
DOCUMENT NUMBER: 3.2-OU1-2 TYPE: REPORT T.O. ACTION:
AUTHOR: STEVE HULSMAN
AUTHOR'S ORG: WASHINGTON STATE DEPT OF HEALTH

ADDRESSEE: BRYAN HAELSIG
ADDRESSEE'S ORG: EFA, NW

ID #: 303

SUB-HEAD: 03.3 RI/FS PROJECT PLANS
TITLE: HEALTH AND SAFETY PLAN OPERABLE UNIT 1

DATE: 2/1/91 # OF PAGES: 240 OPERABLE UNIT: 1
DOCUMENT NUMBER: 3.3-OU1-1 TYPE: REPORT T.O. ACTION:
AUTHOR: SCIENCE APPLICATIONS INTERNATIONAL CORPORATION
AUTHOR'S ORG: SCIENCE APPLICATIONS INTERNATIONAL CORPORATION

ADDRESSEE: URS CONSULTANTS, INC.
ADDRESSEE'S ORG: URS CONSULTANTS, INC.

ID #: 2976

SUB-HEAD: 03.3 RI/FS PROJECT PLANS
TITLE: ADDENDUM TO QUALITY ASSURANCE PROJECT PLAN

DATE: 1/8/93 # OF PAGES: 22 OPERABLE UNIT: 1
DOCUMENT NUMBER: 3.3-OU1-10 TYPE: REPORT T.O. ACTION:
AUTHOR: URS
AUTHOR'S ORG:

ADDRESSEE:
ADDRESSEE'S ORG:

ID #: 2977

SUB-HEAD: 03.3 RI/FS PROJECT PLANS
TITLE: ADDENDUM TO FIELD SAMPLING PLAN

DATE: 1/8/93 # OF PAGES: 17 OPERABLE UNIT: 1
DOCUMENT NUMBER: 3.3-OU1-11 TYPE: REPORT T.O. ACTION:
AUTHOR: URS
AUTHOR'S ORG:

ADDRESSEE:
ADDRESSEE'S ORG:

ID #: 304

SUB-HEAD: 03.3 RI/FS PROJECT PLANS
TITLE: QUALITY ASSURANCE PROJECT PLAN OPERABLE UNIT 1

DATE: 2/1/91 # OF PAGES: 88 OPERABLE UNIT: 1
DOCUMENT NUMBER: 3.3-OU1-2 TYPE: REPORT T.O. ACTION:
AUTHOR: SCIENCE APPLICATIONS INTERNATIONAL CORPORATION
AUTHOR'S ORG: SCIENCE APPLICATIONS INTERNATIONAL CORPORATION

ADDRESSEE: URS CONSULTANTS, INC.
ADDRESSEE'S ORG: URS CONSULTANTS, INC.

ID #: 839

SUB-HEAD: 03.3 RI/FS PROJECT PLANS
TITLE: COMMUNITY RELATIONS PLAN

DATE: 2/1/91 # OF PAGES: 74 OPERABLE UNIT: 1
DOCUMENT NUMBER: 3.3-OU1-3 TYPE: REPORT T.O. ACTION:
AUTHOR: URS
AUTHOR'S ORG:

ADDRESSEE: EFA, NW
ADDRESSEE'S ORG:

ID #: 302

SUB-HEAD: 03.3 RI/FS PROJECT PLANS
TITLE: FIELD SAMPLING PLAN OPERABLE UNIT 1

DATE: 2/1/91 # OF PAGES: 148 OPERABLE UNIT: 1
DOCUMENT NUMBER: 3.3-OU1-4 TYPE: REPORT T.O. ACTION:
AUTHOR: SCIENCE APPLICATIONS INTERNATIONAL CORPORATION
AUTHOR'S ORG: SCIENCE APPLICATIONS INTERNATIONAL CORPORATION

ADDRESSEE: URS CONSULTANTS, INC.
ADDRESSEE'S ORG: URS CONSULTANTS, INC.

ID #: 305

SUB-HEAD: 03.3 RI/FS PROJECT PLANS
TITLE: WORK PLAN OPERABLE UNIT 1

DATE: 2/1/91 # OF PAGES: 118 OPERABLE UNIT: 1
DOCUMENT NUMBER: 3.3-OU1-5 TYPE: REPORT T.O. ACTION:
AUTHOR: SCIENCE APPLICATIONS INTERNATIONAL CORPORATION
AUTHOR'S ORG: SCIENCE APPLICATIONS INTERNATIONAL CORPORATION

ADDRESSEE: URS CONSULTANTS, INC.
ADDRESSEE'S ORG: URS CONSULTANTS, INC.

ID #: 838

SUB-HEAD: 03.3 RI/FS PROJECT PLANS
TITLE: MONTHLY PROGRESS REPORT

DATE: 11/5/91 # OF PAGES: 1 OPERABLE UNIT: 1
DOCUMENT NUMBER: 3.3-OU1-6 TYPE: LETTER T.O. ACTION:
AUTHOR: DAVID B. SHEHEE
AUTHOR'S ORG: MARTIN MARIETTA ENERGY SYSTEM INC.

ADDRESSEE: MR. SCHEIBLE
ADDRESSEE'S ORG: EAGLE PICHER ENVIRONMENTAL SERVICES

ID #: 1155

SUB-HEAD: 03.3 RI/FS PROJECT PLANS
TITLE: CHANGES FOR THE COMMUNITY RELATIONS PLAN (CRP)

DATE: 6/28/91 # OF PAGES: 15 OPERABLE UNIT: 1
DOCUMENT NUMBER: 3.3-OU1-7 TYPE: CHANGES T.O. ACTION:
AUTHOR: URS
AUTHOR'S ORG:

ADDRESSEE:
ADDRESSEE'S ORG:

ENGINEERING FIELD ACTIVITY, NW
NAS WHIDBEY
ADMINISTRATIVE RECORD INDEX

ID #: 1156

S HEAD: 03.3 RI/FS PROJECT PLANS
TITLE: CHANGES TO BE MADE TO THE RI/FS MANAGEMENT PLANS FOR NAS
WHIDBEY ISLAND OPERABLE UNIT 1

DATE: 5/6/91 # OF PAGES: 117 OPERABLE UNIT: 1
DOCUMENT NUMBER: 3.3-OU1-8 TYPE: CORRECTIONS T.O. ACTION:
AUTHOR: SAIC
AUTHOR'S ORG:

ADDRESSEE:
ADDRESSEE'S ORG:

***** ID #: 2975 *****

SUB-HEAD: 03.3 RI/FS PROJECT PLANS
TITLE: WELL CLOSURE PLAN FOR ABANDONMENT OF WELL 6-D-4

DATE: 11/19/92 # OF PAGES: 20 OPERABLE UNIT: 1
DOCUMENT NUMBER: 3.3-OU1-9 TYPE: REPORT T.O. ACTION:
AUTHOR: URS
AUTHOR'S ORG:

ADDRESSEE:
ADDRESSEE'S ORG:

***** ID #: 837 *****

SUB-HEAD: 03.4 ATA/CHAIN OF CUSTODY
TITLE: DOCUMENT TRANSMITTAL - VALIDATED DATA

DATE: 10/7/91 # OF PAGES: 5 OPERABLE UNIT: 1
DOCUMENT NUMBER: 3.4-OU1-1 TYPE: LETTER & ENCLOSUR T.O. ACTION:
AUTHOR: DAVID E. MOHR
AUTHOR'S ORG: URS CONSLULTANTS

ADDRESSEE: BRYAN HAELSIG
ADDRESSEE'S ORG: EFA, NW

***** ID #: 3690 *****

SUB-HEAD: 03.4 ATA/CHAIN OF CUSTODY
TITLE: NOTICE OF LOCATION OF ARCHIVED LABORATORY DATA FOR OU1

DATE: 12/7/93 # OF PAGES: 1 OPERABLE UNIT: 1
DOCUMENT NUMBER: 3.4-OU1-2 TYPE: LETTER T.O. ACTION:
AUTHOR: BRYAN HAELSIG
AUTHOR'S ORG: EFA, NW

ADDRESSEE: ADMINISTRATIVE RECORD
ADDRESSEE'S ORG:

ID #: 3040

SUB-HEAD: 03.6 RI/FS REPORTS
TITLE: FINAL FEASIBILITY STUDY FOR OU1

DATE: 6/93 # OF PAGES: 235 OPERABLE UNIT: 1
DOCUMENT NUMBER: 3.6-OU1-1 TYPE: REPORT T.O. ACTION:
AUTHOR: URS
AUTHOR'S ORG:

ADDRESSEE:
ADDRESSEE'S ORG:

ID #: 3039

SUB-HEAD: 03.6 RI/FS REPORTS
TITLE: FINAL REMEDIAL INVESTIGATION VOL 3 OF 3 APPENDIX I-O

DATE: 6/93 # OF PAGES: OPERABLE UNIT: 1
DOCUMENT NUMBER: 3.6-OU1-2 TYPE: REPORT T.O. ACTION:
AUTHOR: URS
AUTHOR'S ORG:

ADDRESSEE:
ADDRESSEE'S ORG:

ID #: 3041

SUB-HEAD: 03.6 RI/FS REPORTS
TITLE: FINAL REMEDIAL INVESTIGATION FOR OU1 VOL 1 OF 3

DATE: 6/93 # OF PAGES: 688 OPERABLE UNIT: 1
DOCUMENT NUMBER: 3.6-OU1-3 TYPE: REPORT T.O. ACTION:
AUTHOR: URS
AUTHOR'S ORG:

ADDRESSEE:
ADDRESSEE'S ORG:

ID #: 3042

SUB-HEAD: 03.6 RI/FS REPORTS
TITLE: FINAL REMEDIAL INVESTIGATION OU1 VOL 2 OF 3 APPENDIXES A-H

DATE: 6/93 # OF PAGES: 1118 OPERABLE UNIT: 1
DOCUMENT NUMBER: 3.6-OU1-4 TYPE: REPORT T.O. ACTION:
AUTHOR: URS
AUTHOR'S ORG:

ADDRESSEE:
ADDRESSEE'S ORG:

ENGINEERING FIELD ACTIVITY, NW
NAS WHIDBEY
ADMINISTRATIVE RECORD INDEX

ID #: 2978

HEAD: 03.7 PROPOSED PLAN
TITLE: PROPOSED PLANS

DATE: 7/93 # OF PAGES: 12 OPERABLE UNIT: 1
DOCUMENT NUMBER: 3.7-OU1-1 TYPE: BOOKLET T.O. ACTION:
AUTHOR: NAVAL AIR STATION, WHIDBEY
AUTHOR'S ORG:

ADDRESSEE:
ADDRESSEE'S ORG:

ID #: 3292

SUB-HEAD: 04.1 CORRESPONDENCE
TITLE: COMMENTS ON NAS WHIDBEY ISLAND OU1 MONITORING PLAN, REVISED
PRELIMINARY DISCUSSION PLAN

DATE: 7/20/93 # OF PAGES: 3 OPERABLE UNIT: 1
DOCUMENT NUMBER: 4.1-OU1-1 TYPE: LETTER T.O. ACTION:
AUTHOR: PAUL MARCHANT
AUTHOR'S ORG: WASHINGTON STATE DEPT OF ECOLOGY

ADDRESSEE: BRYAN HAELSIG
ADDRESSEE'S ORG: EFA, NW

ID #: 3389

SUB-HEAD: 04.1 CORRESPONDENCE
TITLE: SUBMITTAL OF DRAFT RECORD OF DECISION FOR OU1

DATE: 7/30/93 # OF PAGES: 1 OPERABLE UNIT: 1
DOCUMENT NUMBER: 4.1-OU1-2 TYPE: LETTER T.O. ACTION:
AUTHOR: BELA VARGA
AUTHOR'S ORG: EFA, NW

ADDRESSEE: NANCY HARNEY/PAUL MARCHANT
ADDRESSEE'S ORG: EPA/WASHINGTON STATE DEPT OF ECOLOGY

ID #: 3390

SUB-HEAD: 04.1 CORRESPONDENCE
TITLE: SUBMITTAL OF DRAFT RECORD OF DECISION ON OU 1

DATE: 7/30/93 # OF PAGES: 1 OPERABLE UNIT: 1
DOCUMENT NUMBER: 4.1-OU1-3 TYPE: LETTER T.O. ACTION:
AUTHOR: BELA VARGA
AUTHOR'S ORG: EFA, NW

ADDRESSEE: COMMANDING OFFICER
ADDRESSEE'S ORG: NAS WHIDBEY ISLAND

12/10/93

ENGINEERING FIELD ACTIVITY, NW
NAS WHIDBEY
ADMINISTRATIVE RECORD INDEX

Page 38

ID #: 307

SUB-HEAD: 05.1 CORRESPONDENCE
TITLE: FEDERAL FACILITY AGREEMENT FOR NAS WHIDBEY

DATE: 8/90 # OF PAGES: 2 OPERABLE UNIT: 1
DOCUMENT NUMBER: 5.1-OU1-1 TYPE: LETTER T.O. ACTION:
AUTHOR: SMITH
AUTHOR'S ORG: NAS WHIDBEY

ADDRESSEE: COMMANDER-IN-CHIEF, U.S. PACIFIC FLEET (CODE Ooje)
ADDRESSEE'S ORG:

ID #: 306

SUB-HEAD: 05.1 CORRESPONDENCE
TITLE: FEDERAL FACILITY AGREEMENT FOR NAS WHIDBEY

DATE: 8/10/90 # OF PAGES: 1 OPERABLE UNIT: 1
DOCUMENT NUMBER: 5.1-OU1-2 TYPE: LETTER T.O. ACTION:
AUTHOR: R.F. HEINE, JR.
AUTHOR'S ORG: ENGINEERING FIELD ACTIVITY NORTHWEST

ADDRESSEE: COMMANDER, NAVFACENGCOM (CODE 09CB4)
ADDRESSEE'S ORG:

ID #: 843

SUB-HEAD: 05.1 CORRESPONDENCE
TITLE: CHANGE IN ECOLOGY PROJECT MANAGER

DATE: 8/1/91 # OF PAGES: 1 OPERABLE UNIT: 1
DOCUMENT NUMBER: 5.1-OU1-3 TYPE: LETTER T.O. ACTION:
AUTHOR: DUANE R. GOODMAN
AUTHOR'S ORG: STATE OF WASHINGTON DEPT OF ECOLOGY

ADDRESSEE: PAT VASICEK
ADDRESSEE'S ORG: EFA, NW

ID #: 1969

SUB-HEAD: 05.1 CORRESPONDENCE
TITLE: EXTENDING THE 30 DAY COMMENT PERIOD FOR REVIEW OF THE DRAFT
FEASIBILITY STUDY FOR OU 1 BY NO MORE THAN ONE WEEK

DATE: 7/21/92 # OF PAGES: 1 OPERABLE UNIT: 1
DOCUMENT NUMBER: 5.1-OU1-4 TYPE: LETTER T.O. ACTION:
AUTHOR: PAUL MARCHANT
AUTHOR'S ORG: STATE OF WASHINGTON DEPARTMENT OF ECOLOGY

ADDRESSEE: BRYAN HAELSIG
ADDRESSEE'S ORG: EFA, NW

ENGINEERING FIELD ACTIVITY, NW
NAS WHIDBEY
ADMINISTRATIVE RECORD INDEX

ID #: 3018

SUB-HEAD: 05.1 CORRESPONDENCE
TITLE: QUARTERLY PROGRESS REPORT FOR THIRD QUARTER OF 1992

DATE: 10/23/92 # OF PAGES: 3 OPERABLE UNIT: 1
DOCUMENT NUMBER: 5.1-OU1-5 TYPE: LETTER T.O. ACTION:
AUTHOR: KEVIN STIGILE
AUTHOR'S ORG: EFA, NW

ADDRESSEE: NANCY HARNEY/PAUL MARCHANT
ADDRESSEE'S ORG: EPA/WASHINGTON STATE DEPARTMENT OF ECOLOGY

ID #: 1657

SUB-HEAD: 05.1 CORRESPONDENCE
TITLE: EXTENSION OF 30-DAY COMMENT PERIOD

DATE: 7/21/92 # OF PAGES: 1 OPERABLE UNIT: 1
DOCUMENT NUMBER: 5.1-OU1-5 TYPE: LETTER T.O. ACTION:
AUTHOR: PAUL MARCHANT
AUTHOR'S ORG: DEPARTMENT OF ECOLOGY

ADDRESSEE: BRYAN HAELSIG
ADDRESSEE'S ORG: EFA, NW

ID #: 3296

SUB-HEAD: 05.1 CORRESPONDENCE
TITLE: PROPOSED MODIFICATIONS TO FEDERAL FACILITIES AGREEMENT
DELIVERABLE SCHEDULE FOR OU1

DATE: 10/30/92 # OF PAGES: 6 OPERABLE UNIT: 1
DOCUMENT NUMBER: 5.1-OU1-6 TYPE: LETTER T.O. ACTION:
AUTHOR: V. L. VASAITIS
AUTHOR'S ORG: EFA, NW

ADDRESSEE: NANCY HARNEY/PAUL MARCHANT
ADDRESSEE'S ORG: EPA/WASHINGTON STATE DEPT OF ECOLOGY

ID #: 1971

SUB-HEAD: 05.1 CORRESPONDENCE
TITLE: COMMENTS ON THE SCHEDULE FOR TARGET DATES AND DEADLINES FOR
THE INTERIM ACTION AT OU1

DATE: 9/14/92 # OF PAGES: 1 OPERABLE UNIT: 1
DOCUMENT NUMBER: 5.1-OU1-6 TYPE: LETTER T.O. ACTION:
AUTHOR: PAUL MARCHANT
AUTHOR'S ORG: STATE OF WASHINGTON DEPT OF ECOLOGY

ADDRESSEE: BRYAN HAELSIG
ADDRESSEE'S ORG: EFA, NW

ID #: 3297

SUB-HEAD: 05.1 CORRESPONDENCE
TITLE: APPROVING THE NAVY'S REQUEST FOR MODIFICATION OF FFA SCHEDULE

DATE: 11/9/92 # OF PAGES: 4 OPERABLE UNIT: 1
DOCUMENT NUMBER: 5.1-OU1-7 TYPE: LETTER T.O. ACTION:
AUTHOR: NANCY HARNEY
AUTHOR'S ORG: EPA

ADDRESSEE: BRYAN HAELSIG
ADDRESSEE'S ORG: EFA, NW

ID #: 3298

SUB-HEAD: 05.1 CORRESPONDENCE
TITLE: ADDING DANIEL E. HAYES AS PROJECT MANAGER

DATE: 8/9/93 # OF PAGES: 1 OPERABLE UNIT: 1
DOCUMENT NUMBER: 5.1-OU1-8 TYPE: LETTER T.O. ACTION:
AUTHOR: BELA VARGA
AUTHOR'S ORG: EFA, NW

ADDRESSEE: R. MATTHEW WILKENING/ALI RAAD
ADDRESSEE'S ORG: EPA/WASHINGTON STATE DEPT OF ECOLOGY

ID #: 3023

SUB-HEAD: 05.1 CORRESPONDENCE
TITLE: APPROVING THE EXTENSION OF THE FFA SCHEDULE FOR OU1

DATE: 11/9/92 # OF PAGES: 4 OPERABLE UNIT: 1
DOCUMENT NUMBER: 5.1-OU1-9 TYPE: LETTER T.O. ACTION:
AUTHOR: NANCY HARNEY
AUTHOR'S ORG: EPA

ADDRESSEE: BRYAN HAELSIG
ADDRESSEE'S ORG: EFA, NW

ID #: 3394

SUB-HEAD: 05.1 CORRESPONDENCE
TITLE: STATING MS. MARIAN ABBOTT WILL BE ACTING ECOLOGY PROJECT MANAGER FROM AUG 18, 1993 THROUGH SEPT 6, 1993

DATE: 8/18/93 # OF PAGES: 1 OPERABLE UNIT: 1
DOCUMENT NUMBER: 5.1-OU1-9 TYPE: LETTER T.O. ACTION:
AUTHOR: PAUL MARCHANT
AUTHOR'S ORG: WASHINGTON STATE DEPT OF ECOLOGY

ADDRESSEE: BRYAN HAELSIG
ADDRESSEE'S ORG: EFA, NW

ID #: 3692

SUB-HEAD: 05.2 FFAs/IAGs
TITLE: FEDERAL FACILITIES AGREEMENT

DATE: 10/25/90 # OF PAGES: 60 OPERABLE UNIT: 1
DOCUMENT NUMBER: 5.2-OU1-1 TYPE: REPORT T.O. ACTION:
AUTHOR: EPA
AUTHOR'S ORG:

ADDRESSEE:
ADDRESSEE'S ORG:

ID #: 3416

SUB-HEAD: 05.2 FFAs/IAGs
TITLE: PROPOSED CHANGE TO THE FFA CLARIFYING THE RESPONSIBILITIES
AND AUTHORITIES OF THE PROJECT MANAGERS

DATE: 8/10/93 # OF PAGES: 3 OPERABLE UNIT: 1
DOCUMENT NUMBER: 5.2-OU1-1 TYPE: LETTER T.O. ACTION:
AUTHOR: JUDY A. CONLOW
AUTHOR'S ORG: EFA, NW

ADDRESSEE: JERRY ACKERMAN ESQ.
ADDRESSEE'S ORG: STATE OF WASHINGTON ATTORNEY GENERAL

ID #: 3037

SUB-HEAD: 07.1 CORRESPONDENCE
TITLE: STATING THAT THE GROUNDWATER IN THE SHALLOW AQUIFER BENEATH
AREA 6 IS CONTAMINATED WITH VOLATILE ORGANIC COMPOUNDS
(VOC's)

DATE: 10/14/92 # OF PAGES: 3 OPERABLE UNIT: 1
DOCUMENT NUMBER: 7.1-OU1-1 TYPE: letter T.O. ACTION:
AUTHOR: ROBERT C.. WILLIAMS
AUTHOR'S ORG: DEPT OF HEALTH AND HUMAN SERVICES

ADDRESSEE: CAPTAIN R. R. PENFOLD
ADDRESSEE'S ORG: NAS, WHIDBEY ISLAND

ID #: 3319

SUB-HEAD: 07.1 CORRESPONDENCE
TITLE: SENDING THE INITIAL RELEASE PUBLIC HEALTH ASSESSMENT

DATE: 3/31/93 # OF PAGES: 1 OPERABLE UNIT: 1
DOCUMENT NUMBER: 7.1-OU1-2 TYPE: LETTER T.O. ACTION:
AUTHOR: ROBERT C. WILLIAMS
AUTHOR'S ORG: DEPARTMENT OF HHEALTH & HUMAN SERVICES

ADDRESSEE: BRYAN HAELSIG
ADDRESSEE'S ORG: EFA, NW

ENGINEERING FIELD ACTIVITY, NW
NAS WHIDBEY
ADMINISTRATIVE RECORD INDEX

ID #: 3324

SUB-HEAD: 07.1 CORRESPONDENCE
TITLE: COMMENTS ON THE AGENCY FOR TOXIC SUBSTANCES AND DISEASE
REGISTRY INITIAL RELEASE (RED COVER) PUBLIC HEALTH
ASSESSMENT
DATE: 3/11/93 # OF PAGES: 7 OPERABLE UNIT: 1
DOCUMENT NUMBER: 7.1-OU1-3 TYPE: LETTER T.O. ACTION:
AUTHOR: H. D. KENNEDY JR
AUTHOR'S ORG: DON NAVY ENVIRONMENTAL HEALTH CENTER

ADDRESSEE: COMMANDING OFFICER
ADDRESSEE'S ORG: NAS WHIDBEY

ID #: 3329

SUB-HEAD: 07.1 CORRESPONDENCE
TITLE: RECOMMENDING THAT A SINGLE COORDINATED RESPONSE TO THE
ATSDR BE PREPARED IN ORDER TO MEET THE 20 AUG '93 DEADLINE
DATE: 7/27/93 # OF PAGES: 1 OPERABLE UNIT: 1
DOCUMENT NUMBER: 7.1-OU1-4 TYPE: LETTER T.O. ACTION:
AUTHOR: W. P. THOMAS
AUTHOR'S ORG: DON NAVY ENVIRONMENTAL HEALTH CENTER

ADDRESSEE: NAS WHIDBEY/EFA, NW
ADDRESSEE'S ORG:

ID #: 3334

SUB-HEAD: 07.1 CORRESPONDENCE
TITLE: SENDING COPY OF AGENCY FOR TOXIC SUBSTANCES AND DISEASE
REGISTRY PUBLIC HEALTH ASSESSMENT COMMENT RELEASE
DATE: 7/13/93 # OF PAGES: 2 OPERABLE UNIT: 1
DOCUMENT NUMBER: 7.1-OU1-5 TYPE: LETTER T.O. ACTION:
AUTHOR: ROBERT C. WILLIAMS
AUTHOR'S ORG: DEPARTMENT OF HEALTH & HUMAN SERVICES

ADDRESSEE: BRYAN HAELSIG
ADDRESSEE'S ORG: EFA, NW

APPENDIX B
ADMINISTRATIVE RECORD INDEX

Technical Evaluation Criteria:

- Environmental engineering experience
- Key technical personnel
- Staff in appropriate disciplines

Management Evaluation Criteria:

- Corporate management
- Management plan
- Ability to surge
- Construction management approach
- Management and control systems and reports
- Training
- Health and safety program
- Equipment
- Community relations
- Approved contractor's purchasing system
- Volume of previous DoD awards

The contract announcement covered three regions for the Navy and one contract for each of the regions was awarded. A total of 26 firms responded to the announcement for all three regions. Eleven of the firms were eliminated based on a lack of experience. From the remaining 15 firms, 6 were evaluated for the Northwest region contract:

- URS Consultants, Inc.
Seattle, Washington
- Weston Inc.
Westchester, Pennsylvania
- Riedel Environmental Services
Portland, Oregon
- ICF Kaiser
San Francisco, California
- ENSR Corp.
Houston, Texas
- Ebasco Services, Inc.
New York, New York

Neither EPA nor Ecology had any input into the contractor selection decision.